

Specifications

GTH-844		
Height, stowed	7 ft 10 in	2.39 m
Length, stowed, without forks	20 ft 3 in	6.17 m
Width, standard tires	7 ft 11 in	2.41 m
Wheelbase	11 ft 4 in	3.45 m
Ground clearance, center	1 ft 3 in	38 cm
Ground clearance, axle	1 ft 5 in	43 cm
Weight	22,600 lbs	10251 kg
Working fork height, maximum	43 ft 10 in	13.36 m
Horizontal reach, maximum	28 ft 2 in	8.59 m
Reach at maximum height	2 ft 1 in	64 cm
Lift capacity, maximum height with 24 in / 61 cm load center	6000 lbs	2722 kg
Lift capacity, maximum reach with 24 in / 61 cm load center	2000 lbs	907 kg
Maximum lift capacity	8000 lbs	3629 kg
Drive speed, maximum, Deutz engines		
3-speed transmission	15 mph	24.1 km/h
2-speed transmission	6 mph	10.5 km/h
Drive speed, maximum, Perkins 854 engines		
3-speed transmission	16 mph	25.7 km/h
2-speed transmission	6 mph	10.5 km/h
Drive speed, maximum, Perkins 1104 engines		
3-speed transmission	14 mph	22.5 km/h
2-speed transmission	5.5 mph	9.7 km/h

Tire size	13 x 24, 12 ply	
Turning radius (outside), 2 wheel steer	21 ft 9 in	6.63 m
Turning radius (outside), 4 wheel steer	13 ft 9 in	4.19 m
Frame leveling (each side)	10 degrees	
Fuel tank capacity	35 gal	132.5 liter
Maximum grade	50%	
Horn sound level, manufacturer's rating	113 dB	
Backup alarm sound level, manufacturer's rating	107 dB	
Floor loading information		
Tire load maximum	15,100 lbs	6849 kg
Occupied floor pressure	184 psf	8.8 kPa

Load Charts

GTH-844 Standard Carriage

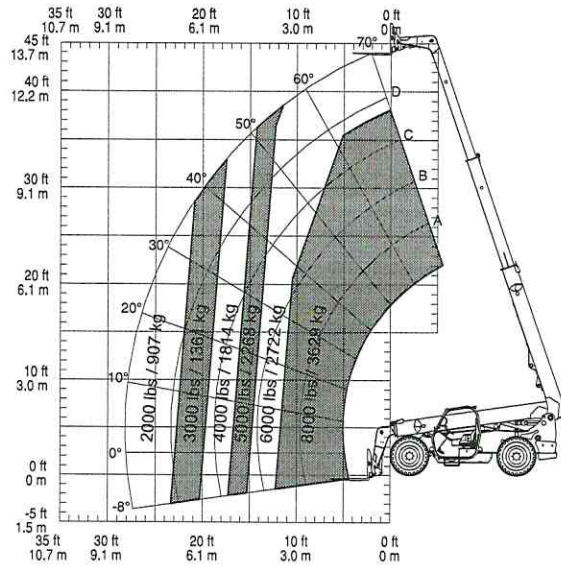

GTH-844 Quick Attach Lifting Point

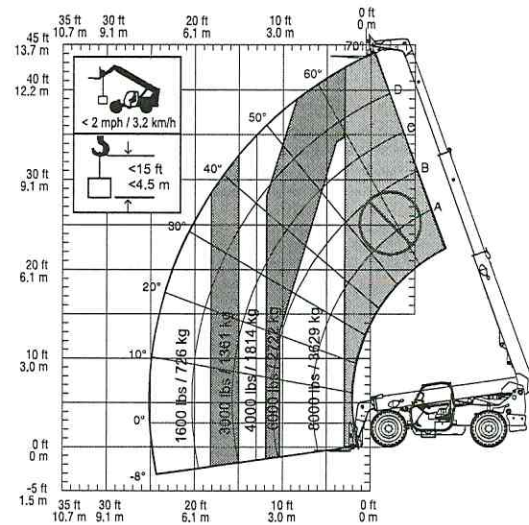

GTH-844 Rotate Carriage

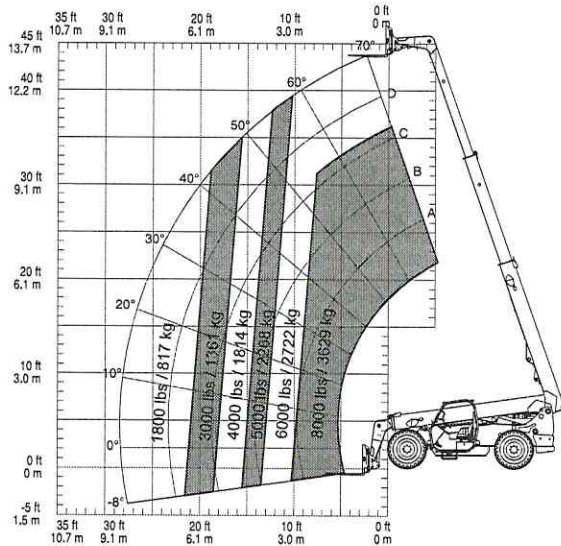

GTH-844 Swing Carriage

