

# Operator's Manual

## Ride-On Roller

# RD12A

# RD12K



Type	RD12A, RD12K
Document	5100037630
Date	1018
Revision	01
Language	EN



5 1 0 0 0 3 7 6 3 0

**Copyright notice**

© Copyright 2018 by Wacker Neuson Production Americas LLC

All rights, including copying and distribution rights, are reserved.

This publication may be photocopied by the original purchaser of the machine. Any other type of reproduction is prohibited without express written permission from Wacker Neuson Production Americas LLC.

Any type of reproduction or distribution not authorized by Wacker Neuson Production Americas LLC represents an infringement of valid copyrights. Violators will be prosecuted.

---

**Trademarks**

All trademarks referenced in this manual are the property of their respective owners.

---

**Manufacturer**

Wacker Neuson Production Americas LLC

N92W15000 Anthony Avenue

Menomonee Falls, WI 53051 U.S.A.

Tel: (262) 255-0500 · Fax: (262) 255-0550 · Tel: (800) 770-0957

[www.wackerneuson.com](http://www.wackerneuson.com)

---

**Original instructions**

This Operator's Manual presents the original instructions. The original language of this Operator's Manual is American English.

---

## CALIFORNIA Proposition 65 Warning



**WARNING**

The engine exhaust from this product contains chemicals known to the State of California to cause cancer, birth defects, or other reproductive harm.

---



**WARNING**

Diesel engine exhaust and some of its constituents are known to the State of California to cause cancer, birth defects, and other reproductive harm.

---



**WARNING**

Cancer and Reproductive Harm -  
[www.P65Warnings.ca.gov](http://www.P65Warnings.ca.gov).

---



**WARNING**

Batteries, battery posts, terminals and related accessories contain lead and lead compounds, and other chemicals known to the State of California to cause cancer and birth defects or other reproductive harm. WASH HANDS AFTER HANDLING.

---

# CALIFORNIA Proposition 65 Warning

Notes



## Foreword

SAVE THESE INSTRUCTIONS—This manual contains important instructions for the machine models below. These instructions have been written expressly by Wacker Neuson Production Americas LLC and must be followed during installation, operation, and maintenance of the machines.

Machine	Item Number
RD12A	5100038333
RD12K	5100038331

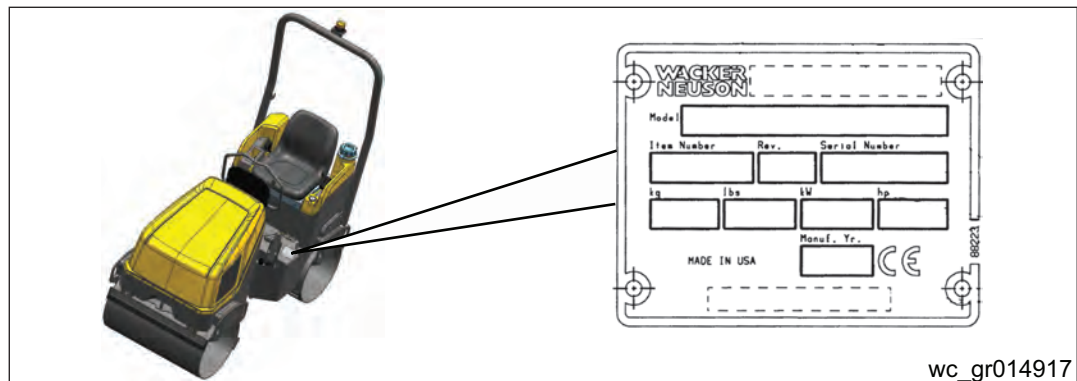

### Machine identification

A nameplate listing the model number, item number, revision number, and serial number is attached to this machine. The location of the nameplate is shown above.

### Serial number (S/N)

For future reference, record the serial number in the space provided below. You will need the serial number when requesting parts or service for this machine.

Serial Number:

### Machine documentation

- From this point forward in this documentation, Wacker Neuson Production Americas LLC will be referred to as Wacker Neuson.
- Keep a copy of the Operator's Manual with the machine at all times.
- For spare parts information, please see your Wacker Neuson Dealer, or visit the Wacker Neuson website at <http://www.wackerneuson.com/>.
- When ordering parts or requesting service information, be prepared to provide the machine model number, item number, revision number, and serial number.

### Expectations for information in this manual

- This manual provides information and procedures to safely operate and maintain the above Wacker Neuson model(s). For your own safety and to reduce the risk of injury, carefully read, understand, and observe all instructions described in this manual.

- Wacker Neuson expressly reserves the right to make technical modifications, even without notice, which improve the performance or safety standards of its machines.
- The information contained in this manual is based on machines manufactured up until the time of publication. Wacker Neuson reserves the right to change any portion of this information without notice.
- The illustrations, parts, and procedures in this manual refer to Wacker Neuson factory-installed components. Your machine may vary depending on the requirements of your specific region.

### CALIFORNIA Proposition 65 Warning

Combustion exhaust, some of its constituents, and certain vehicle components contain or emit chemicals known to the State of California to cause cancer and birth defects or other reproductive harm.

### Laws pertaining to spark arresters

**NOTICE:** State Health Safety Codes and Public Resources Codes specify that in certain locations spark arresters be used on internal combustion engines that use hydrocarbon fuels. A spark arrester is a device designed to prevent accidental discharge of sparks or flames from the engine exhaust. Spark arresters are qualified and rated by the United States Forest Service for this purpose. In order to comply with local laws regarding spark arresters, consult the engine distributor or the local Health and Safety Administrator.

### Manufacturer's approval

This manual contains references to *approved* parts, attachments, and modifications. The following definitions apply:

- **Approved parts or attachments** are those either manufactured or provided by Wacker Neuson.
- **Approved modifications** are those performed by an authorized Wacker Neuson service center according to written instructions published by Wacker Neuson.
- **Unapproved parts, attachments, and modifications** are those that do not meet the approved criteria.

Unapproved parts, attachments, or modifications may have the following consequences:

- Serious injury hazards to the operator and persons in the work area
- Permanent damage to the machine which will not be covered under warranty

Contact your Wacker Neuson dealer immediately if you have questions about approved or unapproved parts, attachments, or modifications.

	<b>CALIFORNIA Proposition 65 Warning</b>	<b>3</b>
	<b>Foreword</b>	<b>5</b>
<b>1</b>	<b>Safety Information</b>	<b>11</b>
1.1	Signal Words Used in this Manual .....	11
1.2	Machine Description and Intended Use .....	12
1.3	Safety Guidelines for Operating the Machine .....	13
1.4	Operating the Machine in Electrical Storms .....	15
1.5	Service Safety .....	15
1.6	Operator Safety while Using Internal Combustion Engines .....	17
1.7	Hydraulic Oil Safety .....	18
1.8	Safety Guidelines for Lifting the Machine .....	18
<b>2</b>	<b>Labels—RD12A (Gasoline)</b>	<b>20</b>
2.1	Label Locations .....	20
2.2	Label Meanings .....	21
<b>3</b>	<b>Lifting and Transporting</b>	<b>28</b>
3.1	Locking and Unlocking the Articulated Steering Joint .....	28
3.2	Lifting the Machine .....	29
3.3	Tying Down and Transporting the Machine .....	31
3.4	Towing the Machine .....	32
3.5	Towing Bypass Valve .....	33
<b>4</b>	<b>Controls—RD12A (Gasoline)</b>	<b>34</b>
4.1	Features and Controls .....	34
4.2	Control Panel and Indicator Lights .....	36
<b>5</b>	<b>Controls—RD12K (Diesel)</b>	<b>38</b>
5.1	Features and Controls .....	38
5.2	Control Panel and Indicator Lights .....	40
<b>6</b>	<b>Operation</b>	<b>42</b>
6.1	Preparing the Machine for First Use .....	42
6.2	Preliminary Checks .....	42

6.3	Recommended Fuel—Gasoline .....	43
6.4	Recommended Fuel—Diesel .....	43
6.5	Rollover Protection Structure (ROPS) .....	44
6.6	Position of the Operator .....	46
6.7	Mounting and Dismounting the Machine .....	46
6.8	Operator Presence System .....	46
6.9	Starting, Operating, and Stopping the RD12A (Gasoline) .....	47
6.10	Starting, Operating, and Stopping the RD12K (Diesel) .....	50
6.11	Positioning the Scrapers .....	53
6.12	Using the Seat Belt .....	54
6.13	Using the Forward/Reverse Lever .....	55
6.14	Using the Vibration System .....	56
6.15	Using the Water Spray System .....	57
6.16	Using the Backup Alarm (if equipped) .....	58
6.17	Using the Work Lights (if equipped) .....	59
6.18	Using the Manual Parking Brake .....	60
6.19	Parking Brake Adjustment .....	61
6.20	Avoiding the Danger Zone .....	62
6.21	Adding Ballast to Rear Drum .....	63
6.22	Emergency Shutdown Procedure .....	64
6.23	Machine Stability .....	65
6.24	Operating on Slopes .....	66
<b>7</b>	<b>General Maintenance</b>	<b>67</b>
7.1	Maintaining the Emission Control System .....	67
7.2	Periodic Maintenance Schedule .....	68
7.3	Opening the Floor Plate .....	69
7.4	Checking the Seat Belt .....	70
7.5	Maintaining the Seat and Seat Belt .....	70
7.6	Checking the Water Filter .....	71
7.7	Cleaning the Water Filter .....	72
7.8	Greasing the Fittings .....	73
7.9	Battery .....	74
7.10	Hydraulic System Cleanliness .....	75
7.11	Hydraulic Oil Requirements .....	75
7.12	Checking the Hydraulic Oil Level .....	76
7.13	Changing the Hydraulic Oil and Filter .....	76
7.14	Bleeding the Hydraulic System .....	77
7.15	Checking the Neutral Switch .....	78
7.16	Testing the Brake System .....	78
7.17	Cleaning the Spray Bars .....	79

7.18	Long-Term Storage .....	80
7.19	Machine Disposal and Decommissioning .....	81
<b>8</b>	<b>Engine Maintenance—Honda GX630 (Gasoline)</b>	<b>82</b>
<b>9</b>	<b>Engine Maintenance—Kubota D902 (Diesel)</b>	<b>84</b>
<b>10</b>	<b>Troubleshooting</b>	<b>87</b>
<b>11</b>	<b>Technical Data—RD12A (Gasoline)</b>	<b>89</b>
11.1	Engine .....	89
11.2	Roller .....	90
11.3	Lubrication .....	90
11.4	Hydraulic Pressures .....	91
11.5	Sound Measurements .....	91
11.6	Measurements of Operator Exposure to Vibration .....	91
11.7	Dimensions .....	92
<b>12</b>	<b>Technical Data—RD12K (Diesel)</b>	<b>93</b>
12.1	Engine .....	93
12.2	Roller .....	94
12.3	Lubrication .....	94
12.4	Hydraulic Pressures .....	95
12.5	Sound Measurements .....	95
12.6	Measurements of Operator Exposure to Vibration .....	95
12.7	Dimensions .....	96
<b>13</b>	<b>Emission Control Systems Information and Warranty—Gasoline</b>	<b>97</b>
13.1	Emission Control System Background Information .....	97
13.2	Limited Defect Warranty for Exhaust Emission Control System .....	98
13.3	Limited Defect Warranty for Wacker Neuson Evaporative Emission Control Systems .....	98
<b>14</b>	<b>Emission Control Systems Information and Warranty—Diesel</b>	<b>101</b>
14.1	Emission Control System Background Information .....	101
14.2	Limited Defect Warranty for Exhaust Emission Control System .....	102
14.3	Limited Defect Warranty for Wacker Neuson Emission Control Systems .....	102

**15 AEM Safety Manual 105**

**16 Schematics—RD12A (Gasoline) 127**

16.1 Hydraulic Schematic ..... 128

16.2 Hydraulic Schematic Components ..... 129

16.3 Electrical Schematic ..... 130

16.4 Electrical Schematic Components ..... 131

## 1 Safety Information

### 1.1 Signal Words Used in this Manual

This manual contains DANGER, WARNING, CAUTION, *NOTICE*, and NOTE signal words which must be followed to reduce the possibility of personal injury, damage to the equipment, or improper service.



This is the safety alert symbol. It is used to alert you to potential personal hazards.

- ▶ Obey all safety messages that follow this symbol.



#### **DANGER**

DANGER indicates a hazardous situation which, if not avoided, will result in death or serious injury.

- ▶ To avoid death or serious injury from this type of hazard, obey all safety messages that follow this signal word.



#### **WARNING**

WARNING indicates a hazardous situation which, if not avoided, could result in death or serious injury.

- ▶ To avoid possible death or serious injury from this type of hazard, obey all safety messages that follow this signal word.



#### **CAUTION**

CAUTION indicates a hazardous situation which, if not avoided, could result in minor or moderate injury.

- ▶ To avoid possible minor or moderate injury from this type of hazard, obey all safety messages that follow this signal word.

**NOTICE:** Used without the safety alert symbol, NOTICE indicates a situation which, if not avoided, could result in property damage.

**Note:** A Note contains additional information important to a procedure.

## 1.2 Machine Description and Intended Use

This machine is a dual drum, ride-on roller. The Wacker Neuson ride-on roller consists of an articulated frame onto which is mounted a gasoline or diesel engine, a fuel tank, a hydraulic tank, a water tank, a hydrostatic drive system, two steel drums containing internal eccentric weights, and an operator's platform with a rollover protective structure (ROPS). The engine powers the hydraulic systems that provide machine movement and drum vibration. The vibrating drums smooth and compact the work surface as the machine moves. Machine speed, direction, and vibration are controlled by the operator from the operator's seat on the platform.

---

The machine is designed as a lightweight roller to be used in the compaction of sublayers and finish layers of asphalt on roads, driveways, parking lots, and other types of asphalt-covered surfaces.

---

This machine has been designed and built strictly for the intended use described above. Using the machine for any other purpose could permanently damage the machine or seriously injure the operator or other persons in the area. Machine damage caused by misuse is not covered under warranty.

The following are some examples of misuse:

- Using the machine as a ladder, support, or work surface
  - Using the machine to carry or transport passengers or equipment
  - Using the machine to tow other machines
  - Using the machine to spray liquids other than water (for example, diesel fuel on asphalt)
  - Operating the machine outside of factory specifications
  - Operating the machine in a manner inconsistent with all warnings found on the machine and in the Operator's Manual
- 

This machine has been designed and built in accordance with the latest global safety standards. It has been carefully engineered to eliminate hazards as far as practicable and to increase operator safety through protective guards and labeling. However, some risks may remain even after protective measures have been taken. They are called residual risks. On this machine, they may include exposure to:

- Heat, noise, exhaust, and carbon monoxide from the engine
- Burns from hot hydraulic fluid
- Fire hazards from improper refueling techniques
- Fuel and its fumes
- Personal injury from improper lifting techniques
- Crushing hazards from improper operation (feet, legs, or arms extending outside of the operator work station) and for other persons in the work zone
- Line of sight blockage by the ROPS

To protect yourself and others, make sure you thoroughly read and understand the safety information presented in this manual before operating the machine.



### 1.3 Safety Guidelines for Operating the Machine

#### Operator training

Before operating the machine:

- Read and understand the operating instructions contained in all manuals delivered with the machine.
- Familiarize yourself with the location and proper use of all controls and safety devices.
- Contact Wacker Neuson for additional training if necessary.

When operating this machine:

- Do not allow improperly trained people to operate the machine. People operating the machine must be familiar with the potential risks and hazards associated with it.

#### Operator qualifications

Only trained personnel are permitted to start, operate, and shut down the machine. They also must meet the following qualifications:

- Have received instruction on how to properly use the machine
- Are familiar with required safety devices

The machine must not be accessed or operated by:

- Children
- People impaired by alcohol, drugs, or prescription drugs

#### Application area

Be aware of the application area.

- Keep unauthorized personnel, children, and pets away from the machine.
- Remain aware of changing positions and the movement of other equipment and personnel in the application area/job site.
- Remain aware of changing surface conditions and use extra care when operating over uneven ground, on hills, or over soft or coarse material. The machine could shift or slide unexpectedly.
- Use caution when operating the machine near the edges of pits, trenches, or platforms. Check to be sure that the ground surface is stable enough to support the weight of the machine with the operator and that there is no danger of the roller sliding, falling, or tipping.
- Do not operate the machine in areas that contain flammable objects, fuels, or products that produce flammable vapors.
- Keep the area around the muffler free of debris such as leaves, paper, cartons, etc. A hot muffler could ignite the debris and start a fire.

#### Safety devices, controls, and attachments

Only operate the machine when:

- All safety devices and guards are in place and in working order.
- All controls operate correctly.
- The machine is set up correctly according to the instructions in the Operator's Manual.
- The machine is clean.
- The machine's labels are legible.

To ensure safe operation of the machine:

- Do not operate the machine if any safety devices or guards are missing or inoperative.
  - Do not modify or defeat the safety devices.
  - Only use accessories or attachments that are approved by Wacker Neuson.
- 

## Safe operating practices

When operating this machine:

- Remain aware of the machine's moving parts. Keep hands, feet, and loose clothing away from the machine's moving parts
- Always remain seated and wear the seat belt at all times while operating the machine.
- Keep clear of the articulated steering joint between the front and rear frames.
- Always disengage and stow the locking bar for the articulated steering joint before operating the machine. The machine cannot be steered when the locking bar is engaged.

And:

- Do not operate a machine in need of repair.
  - Do not drive over curbs or other uneven objects that will result in the machine and operator being shaken.
  - Do not attempt to start the machine when standing alongside it. Only start the engine when seated in the driver's seat and with the forward/reverse control in the neutral position.
  - Do not leave the machine running unattended.
  - Do not use a cellphone or send text messages while operating this machine.
  - Do not consume the operating fluids used in this machine. Depending on your machine model, these operating fluids may include water, wetting agents, fuel (gasoline, diesel, kerosene, propane, or natural gas), oil, coolant, hydraulic fluid, heat transfer fluid (propylene glycol with additives), battery acid, or grease.
- 

## Personal Protective Equipment (PPE)

Wear the following personal protective equipment (PPE) while operating this machine:

- Close-fitting work clothes that do not hinder movement
  - Safety glasses with side shields
  - Hearing protection
  - Safety-toed footwear
- 

## After use

- Stop the engine when the machine is not being operated.
- Close the fuel valve on engines equipped with one when the machine is not being operated.
- Ensure that the machine will not tip over, roll, slide, or fall when not being operated.
- Store the machine properly when it is not being used. The machine should be stored in a clean location out of the reach of children.

## 1.4 Operating the Machine in Electrical Storms



### WARNING

Operating this machine in an electrical storm can be hazardous. You can be injured or killed by lightning.

- ▶ Be aware of deteriorating weather conditions and approaching electrical storms.
- ▶ Stop work and get to a safe shelter before lightning strikes occur.

### Reducing risk of injury

If lightning strikes occur in the vicinity of the work area, there are two methods of reducing risk of injury:

1. If you are on the ground:
  - Stay away from the machine.
  - Do not attempt to climb onto the machine or into the operator's seat.
2. If you are in the operator's seat:
  - Remain in the operator's seat.
  - Do not attempt to climb off the machine.

## 1.5 Service Safety

### Service training

Before servicing or maintaining the machine:

- Read and understand the instructions contained in all manuals delivered with the machine.
- Familiarize yourself with the location and proper use of all controls and protective devices.
- Only trained personnel shall troubleshoot or repair problems occurring with the machine.
- Contact Wacker Neuson for additional training if necessary.

When servicing or maintaining this machine:

- Do not allow untrained or improperly trained people to service or maintain the machine. Personnel servicing or maintaining the machine must be familiar with the associated potential risks and hazards.

### Precautions

When servicing or maintaining the machine:

- Read and understand the service procedures before performing any service to the machine.
- All adjustments and repairs must be completed before operating the machine. Do not operate the machine with a known problem or deficiency.
- All repairs and adjustments shall be completed by a qualified technician.
- Turn off the machine before performing maintenance or making repairs.
- Remain aware of the machine's moving parts. Keep hands, feet, and loose clothing away from the machine's moving parts.
- Reinstall the safety devices and guards after repair and maintenance procedures are complete.

## Machine modifications

When servicing or maintaining the machine:

- Use only accessories/attachments that are approved by Wacker Neuson.
  - Do not defeat safety devices.
  - Do not modify the machine without the express written approval of Wacker Neuson.
- 

## Replacing parts and labels

- Replace worn or damaged components.
  - Replace all missing and hard-to-read labels.
  - When replacing electrical components, use components that are identical in rating and performance to the original components.
  - When replacement parts are required for this machine, use only Wacker Neuson replacement parts or those parts equivalent to the original in all types of specifications, such as physical dimensions, type, strength, and material.
- 

## Cleaning

When cleaning and servicing the machine:

- Keep machine clean and free of debris such as leaves, paper, cartons, etc.
  - Keep labels legible.
  - Do not clean the machine while it is running.
  - Never use gasoline or other types of fuels or flammable solvents to clean the machine. Fumes from fuels and solvents can become explosive.
- 

## Personal Protective Equipment (PPE)

Wear the following Personal Protective Equipment (PPE) while servicing or maintaining this machine:

- Close-fitting work clothes that do not hinder movement
- Safety glasses with side shields
- Hearing protection
- Safety-toed footwear

In addition, before servicing or maintaining the machine:

- Tie back long hair.
- Remove all jewelry (including rings).

## 1.6 Operator Safety while Using Internal Combustion Engines



### WARNING

Internal combustion engines present special hazards during operation and fueling. Failure to follow the warnings and safety standards could result in severe injury or death.

- ▶ Read and follow the warning instructions in the engine owner's manual and the safety guidelines below.



### DANGER

Exhaust gas from the engine contains carbon monoxide, a deadly poison. Exposure to carbon monoxide can kill you in minutes.

- ▶ NEVER operate the machine inside an enclosed area, such as a tunnel, unless adequate ventilation is provided through items such as exhaust fans or hoses.

### Operating safety

When running the engine:

- Keep the area around the exhaust pipe free of flammable materials.
- Check the fuel lines and the fuel tank for leaks and cracks before starting the engine. Do not run the machine if fuel leaks are present or the fuel lines are loose.
- Do not smoke while operating the machine.
- Do not run the engine near sparks or open flames.
- Do not touch the engine or muffler while the engine is running or immediately after it has been turned off.
- Do not operate a machine when its fuel cap is loose or missing.
- Do not start the engine if fuel has spilled or a fuel odor is present. Move the machine away from the spill and wipe the machine dry before starting.
- Do not use the machine in areas with risk of explosion or fire.

### Refueling safety

When refueling the engine:

- Clean up any spilled fuel immediately.
- Refill the fuel tank in a well-ventilated area.
- Reinstall the fuel tank cap after refueling.
- Use tools specifically meant for refueling (for example, a fuel hose or funnel).
- Do not smoke.
- Do not refuel a hot or running engine.
- Do not refuel the engine near sparks or open flames.

## 1.7 Hydraulic Oil Safety



### WARNING

Possibility of severe injury. Hydraulic oil is under high pressure and becomes very hot during operation.

- ▶ To avoid injury, obey the safety instructions listed below.

### Safety instructions

- Inspect the hydraulic system thoroughly before operating the machine.
- Do not touch hydraulic oil or hydraulic components while the machine is operating. Wait until the machine is cool.
- Before disconnecting hydraulic fittings or hoses, ensure that all pressure has been bled from the circuit. Set all controls in neutral, turn the engine off, and allow the fluids to cool before loosening hydraulic fittings or attaching test gauges.
- Hydraulic oil escaping under high pressure may penetrate the skin, causing burns, blindness, or other serious injuries or infections. Contact a physician immediately for treatment if your skin has been penetrated by hydraulic oil, even if the wound seems minor.
- Fluid leaks from small holes are often practically invisible. Do not use your bare hands to check for leaks. Check for leaks using a piece of cardboard or wood.
- Hydraulic oil is extremely flammable. Stop the engine immediately if a hydraulic leak is detected.
- After servicing the hydraulics, make sure all components are reconnected to the proper fittings. Failure to do so may result in damage to the machine and/or injury to a person on or near the machine.

## 1.8 Safety Guidelines for Lifting the Machine

When lifting the machine:

- Make sure slings, chains, hooks, ramps, jacks, forklifts, cranes, hoists, and any other type of lifting device used is attached securely and has enough weight-bearing capacity to lift or hold the machine safely. See the *Technical Data* chapter for machine weight.
- Remain aware of the location of other people when lifting the machine.
- Only use the lifting points and tie-downs described in the Operator's Manual.
- Make sure the transporting vehicle has sufficient load capacity and platform size to safely transport the machine.

To reduce the possibility of injury:

- Do not stand under the machine while it is being lifted or moved.
- Do not get onto the machine while it is being lifted or moved.

Notes

2 Labels—RD12A (Gasoline)

2.1 Label Locations

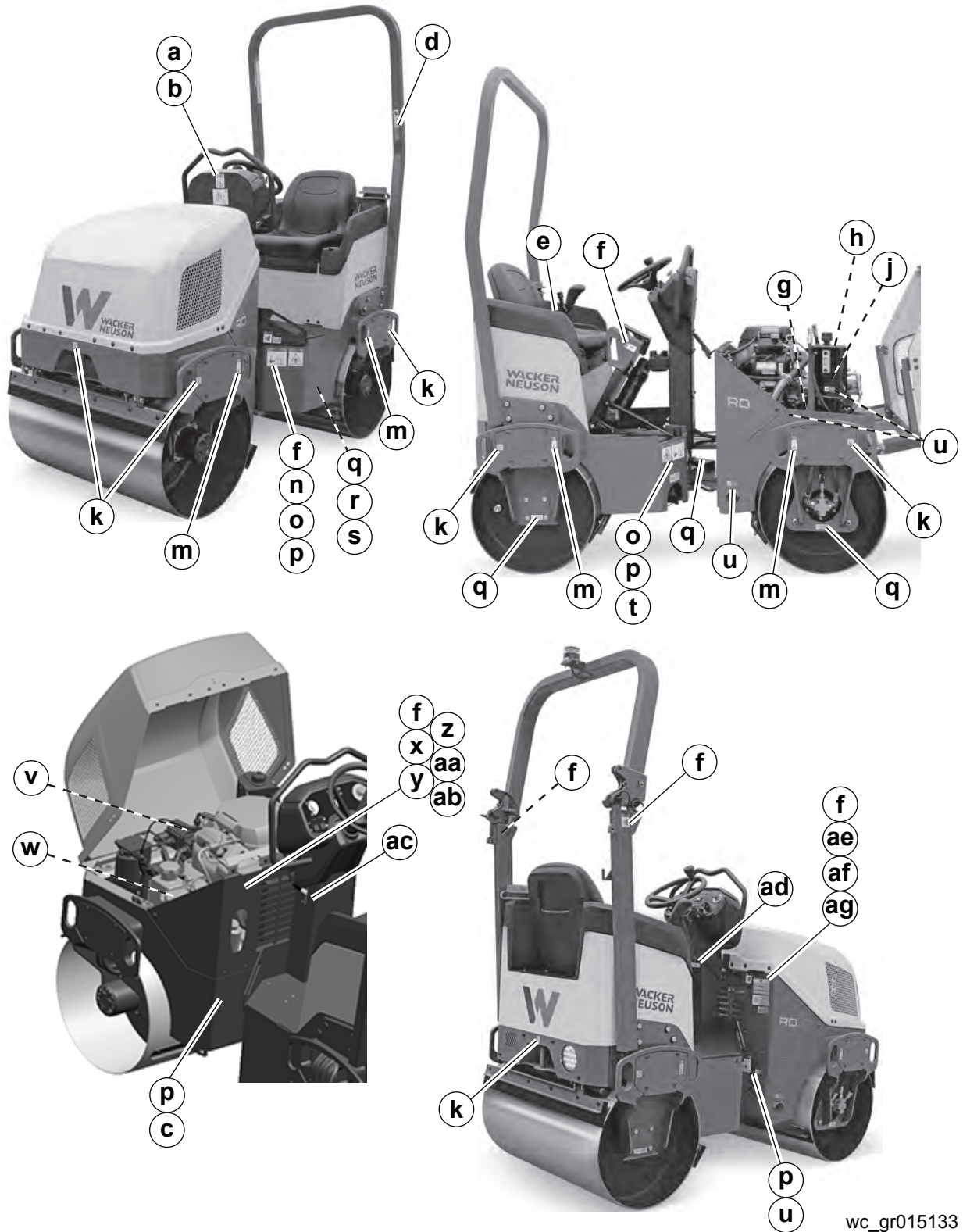





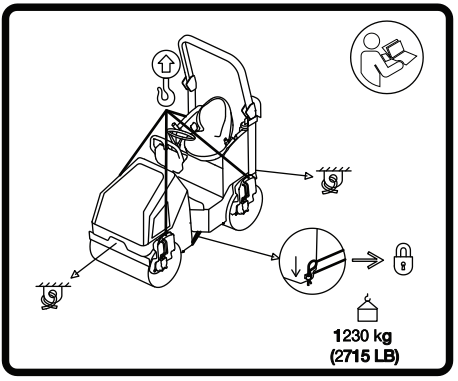
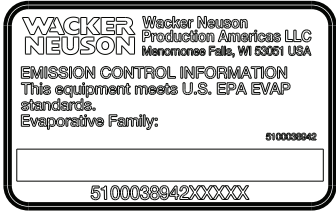
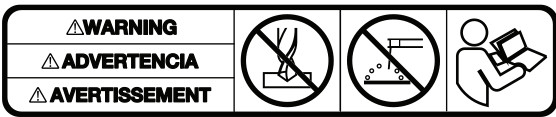
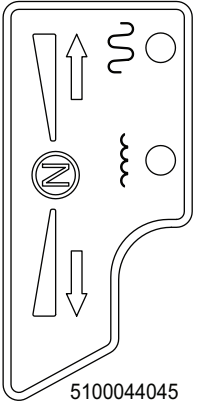

wc\_gr015133

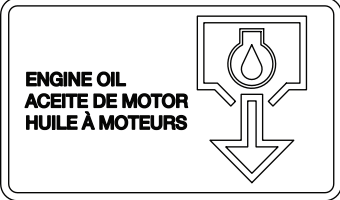

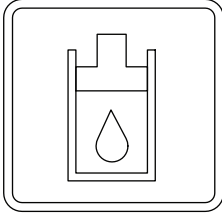
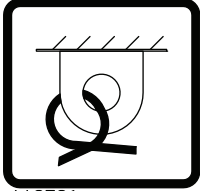
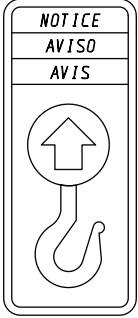

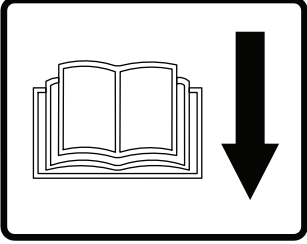

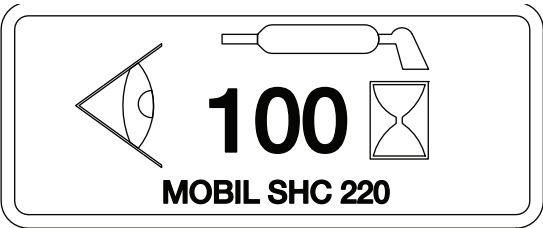

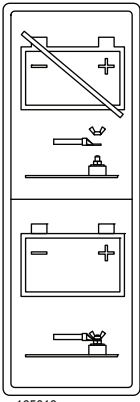

2.2 Label Meanings

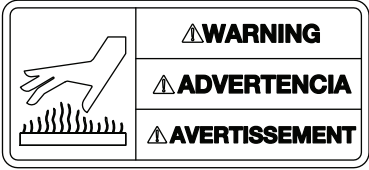



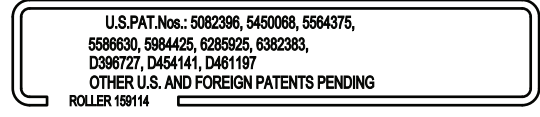

<p>a</p>	 <p>165020</p>	<p><b>CAUTION</b> No lift point</p>
<p>b</p>	 <p>5100044042</p>	<p><b>NOTICE</b> Lifting point</p> <ul style="list-style-type: none"> <li>■ Lock articulated steering joint.</li> <li>■ Attach chains to the lifting eyes on machine.</li> <li>■ Attach chains to hook on lifting equipment.</li> </ul>
<p>c</p>	 <p>5100038942</p>	<p>Emission Control Information This equipment meets U.S. EPA EVAP standards.</p>
<p>d</p>	 <p>5200005875</p>	<p><b>WARNING</b> Do not drill or weld the ROPS. Read the Operator's Manual.</p>
<p>e</p>	 <p>5100044045</p>	<p>Handgrip controls</p>

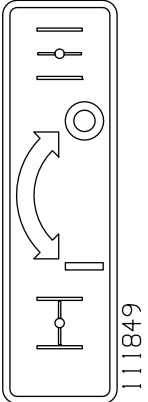
<p>f</p>		<p><b>WARNING</b> Avoid crushing area.</p>
<p>g</p>		<p>Engine oil drain</p>
<p>h</p>		<p><b>CAUTION</b> Read and understand the supplied Operator's Manual before operating this machine. Failure to do so increases the risk of injury to yourself and others.</p>
<p>j</p>		<p>Hydraulic oil reservoir fill</p>
<p>k</p>		<p>Tie-down point</p>
<p>m</p>		<p><b>NOTICE</b> Lifting point</p>

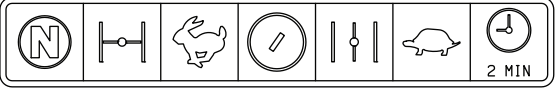
<p>n</p>	 <p>5100018721</p>	<p>Operator's Manual must be stored on machine. Replacement Operator's Manual can be ordered through your local Wacker Neuson distributor.</p>
<p>o</p>	 <p>5100044046</p>	<p><b>WARNING</b> Avoid crushing area. Articulated steering joint locking location. Lock the articulated steering joint before servicing the machine. Read Repair Manual.</p>
<p>p</p>	 <p>110176</p>	<p><b>WARNING</b> Pinch point.</p>
<p>q</p>	 <p>5100044047</p>	<p>Grease points: Inspect and lubricate every 100 hours of operation.</p>
<p>r</p>	 <p>161701</p>	<p><b>WARNING</b> Disconnect battery before servicing. Read Repair Manual for instructions. Battery contains caustic acid and potentially explosive hydrogen gas.</p>

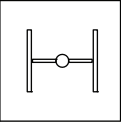
<p><b>s</b></p>	 <p>165018</p>	<p>Disconnect battery before servicing.</p>
<p><b>t</b></p>	 <p>172281</p>	<p>Water tank fill</p>
<p><b>u</b></p>	 <p>115415</p>	<p><b>WARNING</b> Hot surface</p>
<p><b>v</b></p>	 <p>170982</p>	<p><b>CAUTION</b> Read and understand the supplied Operator's Manual before operating this machine. Failure to do so increases the risk of injury to yourself and others.</p>
<p><b>w</b></p>	 <p>117034</p>	<p><b>DANGER</b> Asphyxiation hazard</p> <ul style="list-style-type: none"> <li>■ Engines emit carbon monoxide.</li> <li>■ Do not run the machine indoors or in an enclosed area unless adequate ventilation, through such items as exhaust fans or hoses, is provided.</li> <li>■ Read the Operator's Manual.</li> <li>■ No sparks, flames, or burning objects near the machine.</li> <li>■ Stop the engine before refueling.</li> </ul>

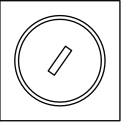
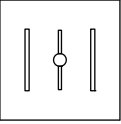
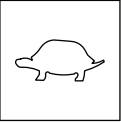
<p>x</p>	 <p>118362</p>	<p><b>WARNING</b> Always wear seat belt when operating roller.</p> <p>Read the Operator's Manual for machine information.</p>
<p>y</p>		<p><b>WARNING</b> Operation of this equipment may create sparks that can start fires around dry vegetation. A spark arrester may be required. The operator should contact local fire agencies for laws or regulations relating to fire prevention requirements.</p>
<p>z</p>		<p>This machine may be covered by one or more patents.</p>
<p>aa</p>		<p>California Proposition 65 Warning Cancer and Reproductive Harm - www.P65Warnings.ca.gov.</p>
<p>ab</p>		<p>Industry Canada ICES-002 Compliance Label: CAN ICES-2/NMB-2</p>
<p>ac</p>		<p>Choke: O = Open  I = Closed</p>

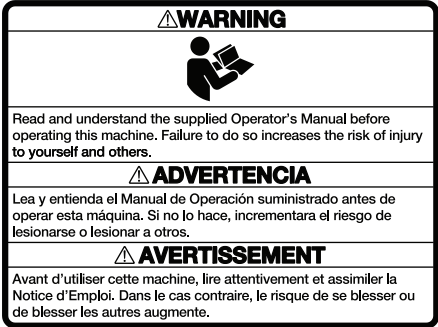
<p>ad</p>	 <p>5100044044</p>	<p>Starting the machine.</p>
		<p>Put the machine in neutral.</p>
		<p>Close the choke.</p>
		<p>Turn the throttle to rabbit.</p>
		<p>Turn the engine key to the START position.</p>
		<p>Open the choke.</p>
		<p>Turn the throttle to turtle.</p>
		<p>Allow the machine to warm-up for at least 2 minutes before operation.</p>
<p>ae</p>	 <p>176103</p>	<p>Read and understand the supplied Operator's Manual before operating this machine. Failure to do so increases the risk of injury to yourself or others.</p>

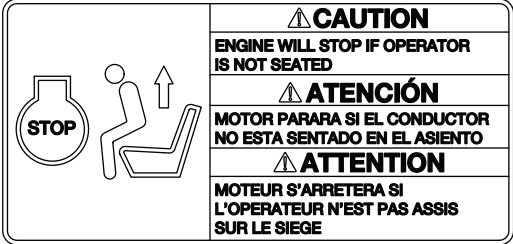
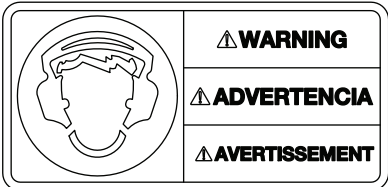
<p>af</p>	 <p>165001</p>	<p>Engine will stop if operator is not seated and the machine is in forward or reverse.</p>
<p>ag</p>	 <p>114789</p>	<p><b>WARNING</b> To reduce the risk of hearing loss, always wear hearing protection when operating this machine.</p>

### 3 Lifting and Transporting

#### 3.1 Locking and Unlocking the Articulated Steering Joint

**Description** A lockarm located below the articulated steering joint is provided to fasten the front and rear halves of the roller together. Once secured, the lockarm prevents the frame halves of the machine from unintentionally coming together.

**WARNING**

Pinching/crushing hazards.

- ▶ Always install the lockarm before you lift the machine, transport the machine, or perform maintenance near the center of the machine.

**Locking**

Move the lockarm **(a)** to the LOCKED position **(1)**. Fasten the lockarm in place with the retaining pin **(b)**.

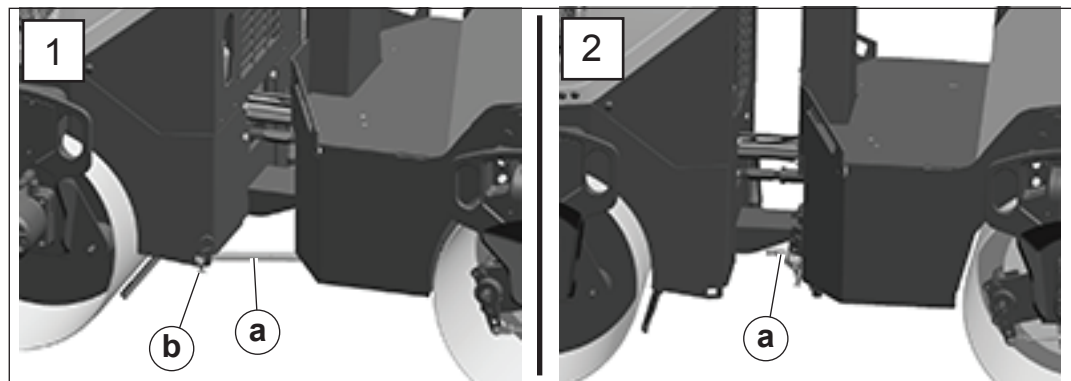

wc\_gr014301

**Unlocking**

Remove the retaining pin and move the lockarm to the UNLOCKED position **(2)** before you operate the machine. Reinsert the retaining pin in the lockarm.

**NOTICE:** Attempting to steer the machine with the lockarm in the locked position may damage the steering cylinder and locking mechanism.



## 3.2 Lifting the Machine

- Requirements**
- Lifting equipment (crane or hoist) capable of supporting the machine's weight. See the *Technical Data* chapter for your machine.
  - Lifting devices (hooks, chains, and shackles) capable of supporting the machine's weight.
  - All access covers closed and secured.

**WARNING**

Crushing hazard. You may be crushed if the lifting devices fail.

- ▶ Never stand under, or get onto, the machine while it is being lifted or moved.

**WARNING**

Crushing hazard. The machine can drop if it is lifted by the ROPS or any other part of the frame. These components are not designed to support the weight of the machine.

- ▶ Use only the designated lifting points to lift the machine.

**Procedure** Perform the procedure below to lift the machine.

1. Stop the engine.
2. Apply the parking brake.
3. Lock the articulated steering joint **(a)**.



wc\_gr014287

*This procedure continues on the next page.*

*Continued from the previous page.*

4. There are two lifting eyes (**b**) per side. Attach one lifting chain to each lifting eye.

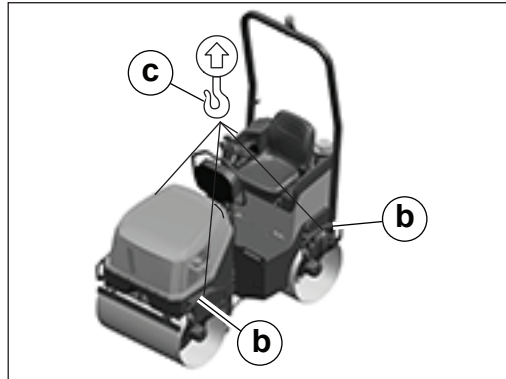

wc\_gr014302

5. Attach the chains to the hook (**c**) of the lifting equipment.
6. Lift the machine a small distance.



## **WARNING**

Crushing hazard. An unstable machine may cause the lifting device to fail. You may be crushed if the lifting device fails.

- ▶ Check for machine stability before continuing.

7. Check for stability. If necessary, lower the machine, reposition the lifting devices, and lift the machine a small distance again.
8. Continue lifting the machine only when it is stable.

### 3.3 Tying Down and Transporting the Machine

- Requirements**
- Engine shut down
  - Apply the parking brake

**Procedure** Perform the procedure below to tie down the machine.

1. Make sure that the transport vehicle is capable of handling the weight and size of the machine. See *Technical Data* for dimensions and operating weight.
2. Lock the articulated steering joint (**a**).

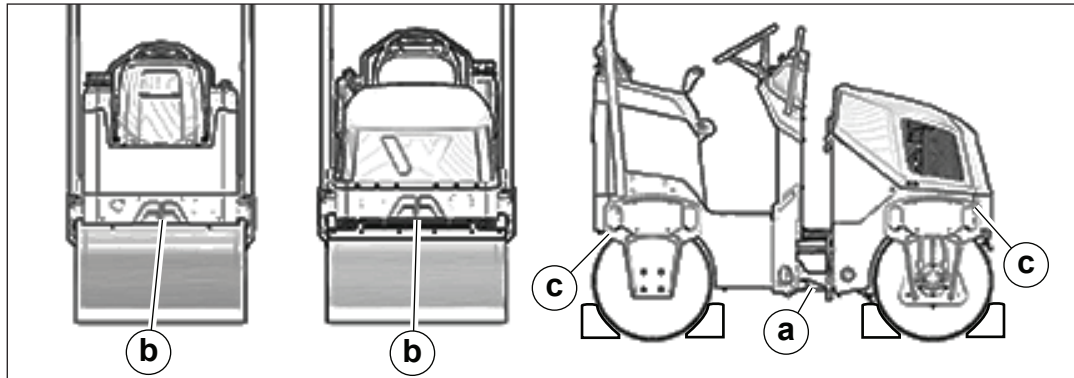

wc\_gr014303

3. Block or chock the drums as shown.
4. Attach steel ropes or chains to each of the two tie down bars (**b**) or drum supports (**c**) on the front and rear of the machine.
5. Attach the other end of the chains to the transport vehicle.

**NOTICE**

- Do not position ropes or chains across the machine frame or the articulated steering joint when tying down the machine. Damage to the machine may occur.
- Do not completely compress the shock mounts when tying down the machine. Damage to the shock mounts may occur.
- Do not leave the machine tied down for extended periods of time (except when transporting). Damage to the shock mounts may occur.

### 3.4 Towing the Machine

- Requirements**
- Second machine of greater size and rigid towing equipment, or
  - Two machines of equal size to towed machine if non-rigid towing equipment is being used
  - Shielding for all machines being used

**Note:** *The strength of the towing line or the tow bar should be at least 150 percent of the gross weight of the towing machine.*

---

- Limitations**
- The following limitations must be followed:
- Limit towing to emergency situations only
  - Limit towing to short distances
  - Limit towing speed to 2 km/h (1.2 mph)
  - Limit tow line angle to 30°
- 

**Procedure**

Perform the procedure below to tow the machine.

**Note:** *If the engine runs and the steering system and/or braking system functions, an operator may be allowed to ride on and steer the machine being towed. In all other cases, do not ride on the machine when it is being towed.*

1. Attach shielding to the machines to protect the operators if the towing equipment breaks.
  2. Apply the parking brake so that the machine cannot move.
  3. Open the engine compartment.
  4. Open the pump bypass by turning the towing bypass valve two turns counterclockwise. See *Towing Bypass Valve*.
- NOTICE:** Opening the towing bypass valve more than two turns could cause hydraulic oil leakage.
5. Attach the tow line to the machine at the tow points.
  6. Attach the tow line to the towing vehicle(s).
  7. Release the parking brake.
  8. Tow the disabled machine at a slow rate of speed to the desired location.
  9. Once the machine is at the desired location, apply the parking brake. This will prevent movement of the machine.
  10. Close the towing bypass valve by turning it clockwise.
  11. Remove the tow lines.

### 3.5 Towing Bypass Valve

The drive circuit is equipped with a towing bypass valve (a) to allow oil to bypass the drive motors and let the roller freewheel for towing.

The towing bypass valve should be used in emergency cases where the machine has become stuck in loose or muddy soil, or cannot be driven due to an engine or hydraulic system failure.

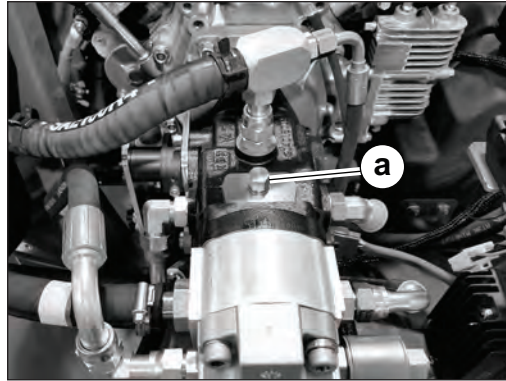

wc\_gr014323



#### WARNING

With the towing bypass valve open, the drive circuit has no braking action and the machine will roll freely.

- ▶ Apply the brake or attach the towing device before opening the towing bypass valve.
- ▶ Close the towing valve immediately after the towing operation is complete to prevent the machine from rolling unexpectedly.

#### Procedure

1. Open the pump bypass by turning the towing bypass valve two turns counterclockwise. See *Towing the Machine*.

**NOTICE:** Opening the towing bypass valve more than two turns could cause hydraulic oil leakage.

2. Close the pump bypass by turning the towing bypass valve clockwise.

4 Controls—RD12A (Gasoline)

4.1 Features and Controls

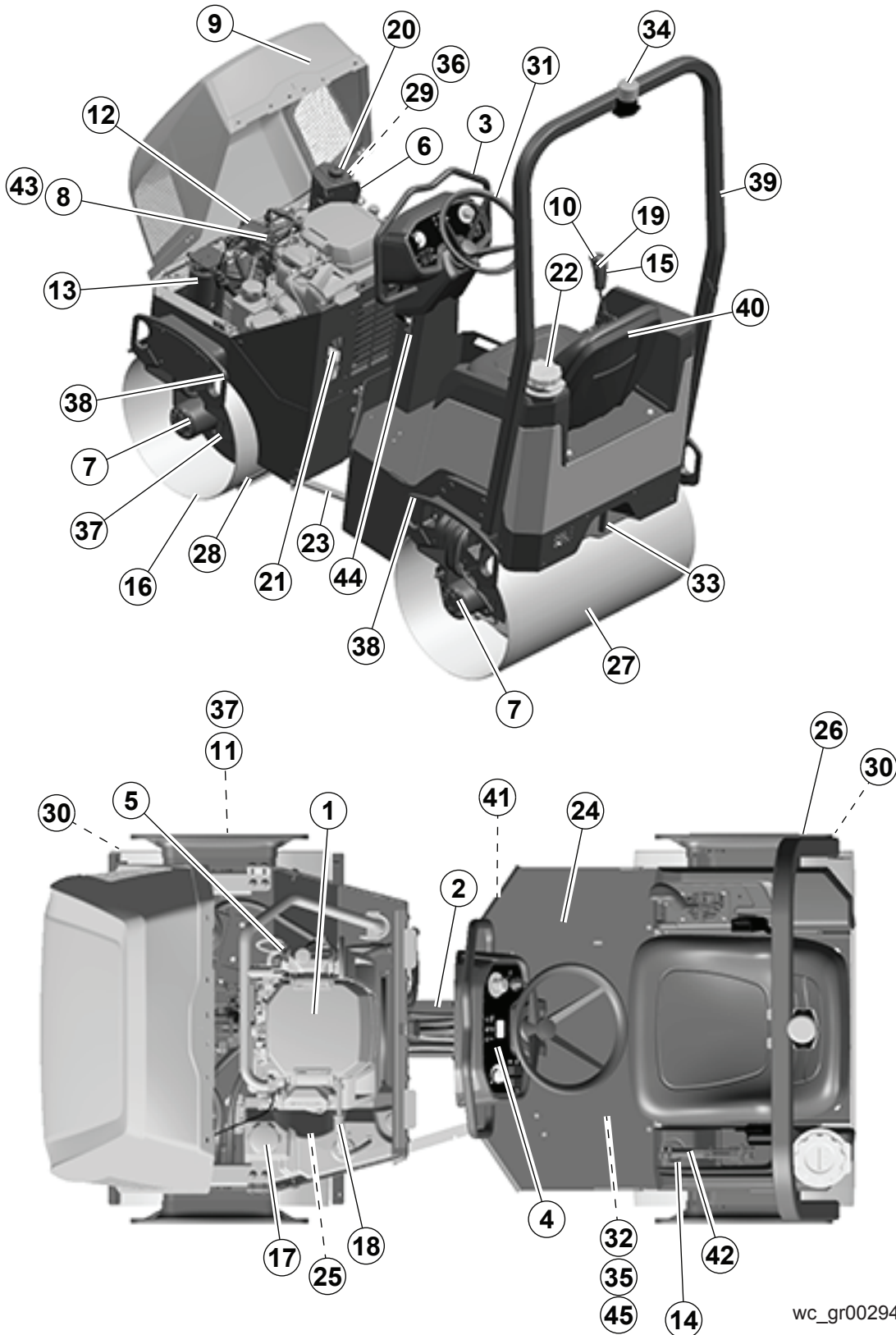

wc\_gr002946

Ref.	Description	Ref.	Description
1	Air cleaner	23	Lockarm
2	Articulated steering joint	24	Operator's platform
3	Hand holds	25	Engine oil filter
4	Control panel	26	Rear drum fill/drain plug
5	Dipstick	27	Rear drum—static
6	Drain hose—hydraulic tank	28	Scraper bar (4 places)
7	Drive motor	29	Sightglass—hydraulic tank
8	Drive pump	30	Spray bar (2)
9	Engine hood	31	Steering wheel
10	Vibration control button	32	Steering cylinder (under floor panel)
11	Exciter motor	33	Tiedown/tow bar (2 places)
12	Exciter/Steering pump	34	Beacon light (optional)
13	Hydraulic filter—return line	35	Battery (under floor panel)
14	Water gauge	36	Hydraulic suction line
15	Forward / Reverse control	37	Grease fitting—exciter (2 places)
16	Front drum—vibratory	38	Lifting eye (4 places)
17	Fuel tank fill cap	39	ROPS
18	Fuel filter	40	Seat with seatbelt
19	Water spray button	41	Water drain
20	Hydraulic tank fill port	42	Parking brake
21	Fuel gauge	43	Towing bypass valve
22	Water tank fill cap	44	Choke lever
—	—	45	Check Valve

4.2 Control Panel and Indicator Lights

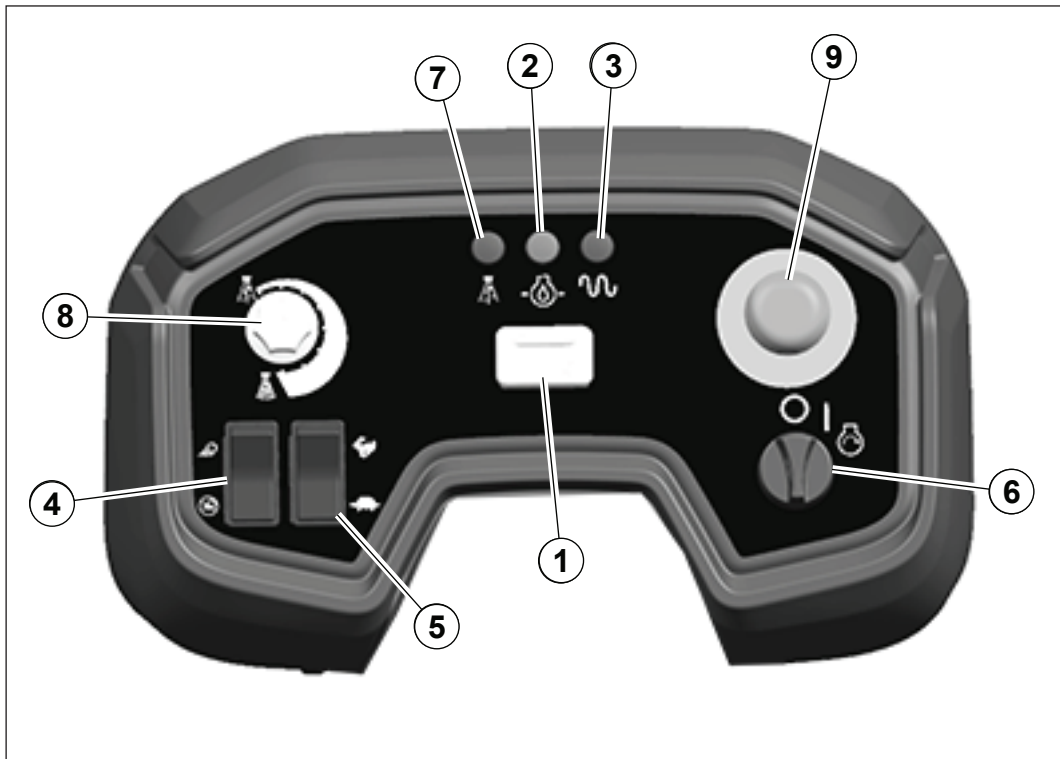

wc\_gr004114

Ref.	Item	Function
1	Hour meter	This instrument meters machine usage.
2	Low engine oil pressure indicator	This light illuminates when the ignition switch (6) is in the ON position and the engine is not running; it goes out once the engine has started. If the light illuminates when the engine is running, it indicates that the engine oil pressure is low. Do not operate the machine if this light is illuminated.
3	Vibration on indicator	This indicator light illuminates to indicate that the vibration is on.
4	Lights switch (if equipped)	This switch controls power to the lights.
5	Throttle switch	This switch sets the position of the throttle, either high or low.
6	Ignition switch	This switch starts or stops the engine.
7	Water spray indicator	This indicator shows whether the water spray is off or on.
8	Water spray dial	This dial sets the frequency at which the water pump turns on and off to control the water output rate.
9	Engine stop switch	This switch shuts down the engine. Pull the switch up to all the engine to run.



Notes

5 Controls—RD12K (Diesel)

5.1 Features and Controls

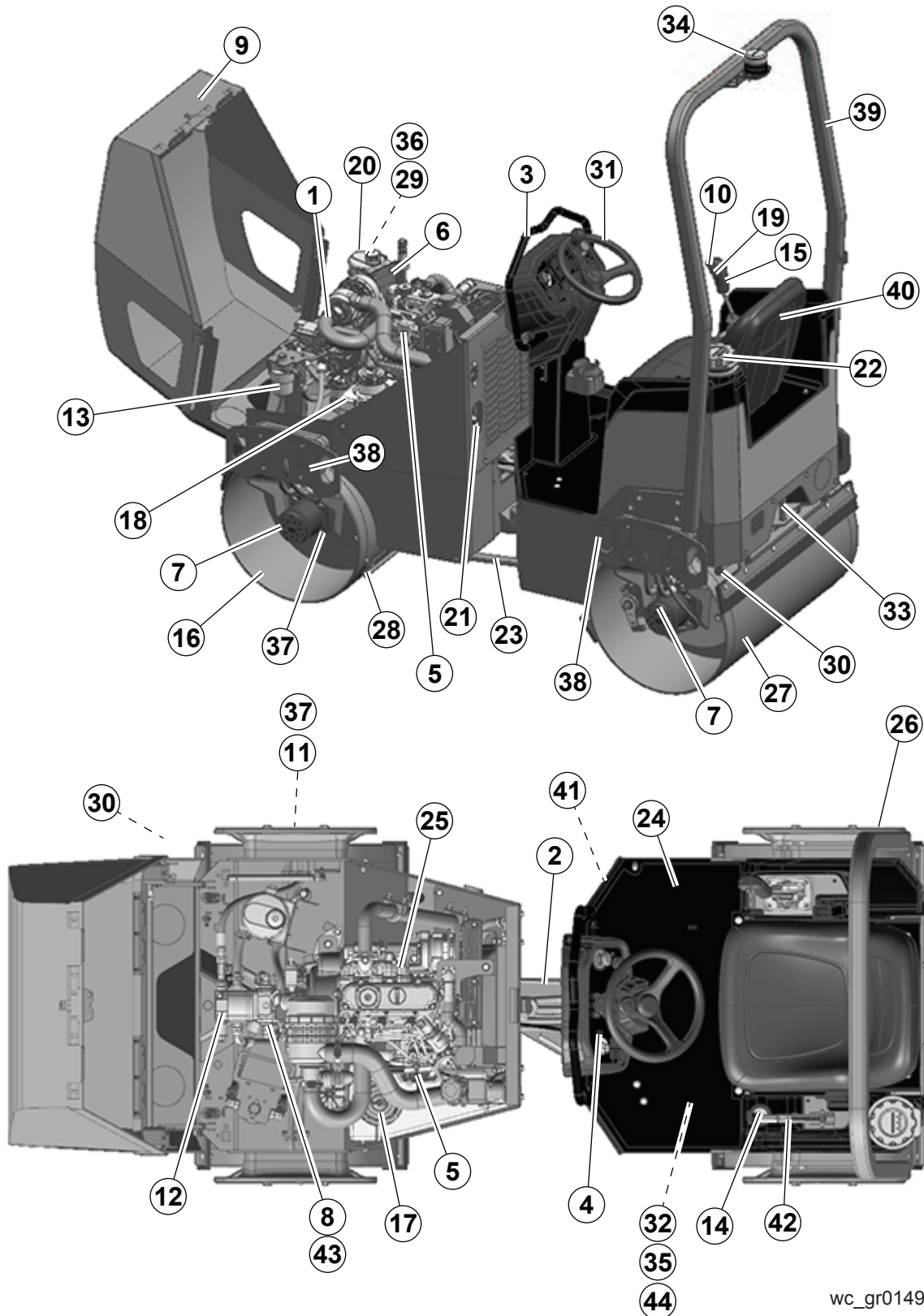

wc\_gr014991

Ref.	Description	Ref.	Description
1	Air cleaner	23	Lockarm
2	Articulated steering joint	24	Operator's platform
3	Hand holds	25	Engine oil filter
4	Control panel	26	Rear drum fill/drain plug
5	Dipstick	27	Rear drum—static
6	Drain hose—hydraulic tank	28	Scraper bar (4 places)
7	Drive motor	29	Sightglass—hydraulic tank
8	Drive pump	30	Spray bar (2)
9	Engine hood	31	Steering wheel
10	Vibration control button	32	Steering cylinder (under floor panel)
11	Exciter motor	33	Tiedown/tow bar (2 places)
12	Exciter/Steering pump	34	Beacon light (optional)
13	Hydraulic filter—return line	35	Battery (under floor panel)
14	Water gauge	36	Hydraulic suction line
15	Forward / Reverse control	37	Grease fitting—exciter (2 places)
16	Front drum—vibratory	38	Lifting eye (4 places)
17	Fuel tank fill cap	39	ROPS
18	Fuel filter	40	Seat with seatbelt
19	Water spray button	41	Water drain
20	Hydraulic tank fill port	42	Parking brake
21	Fuel gauge	43	Towing bypass valve
22	Water tank fill cap	44	Check Valve

5.2 Control Panel and Indicator Lights

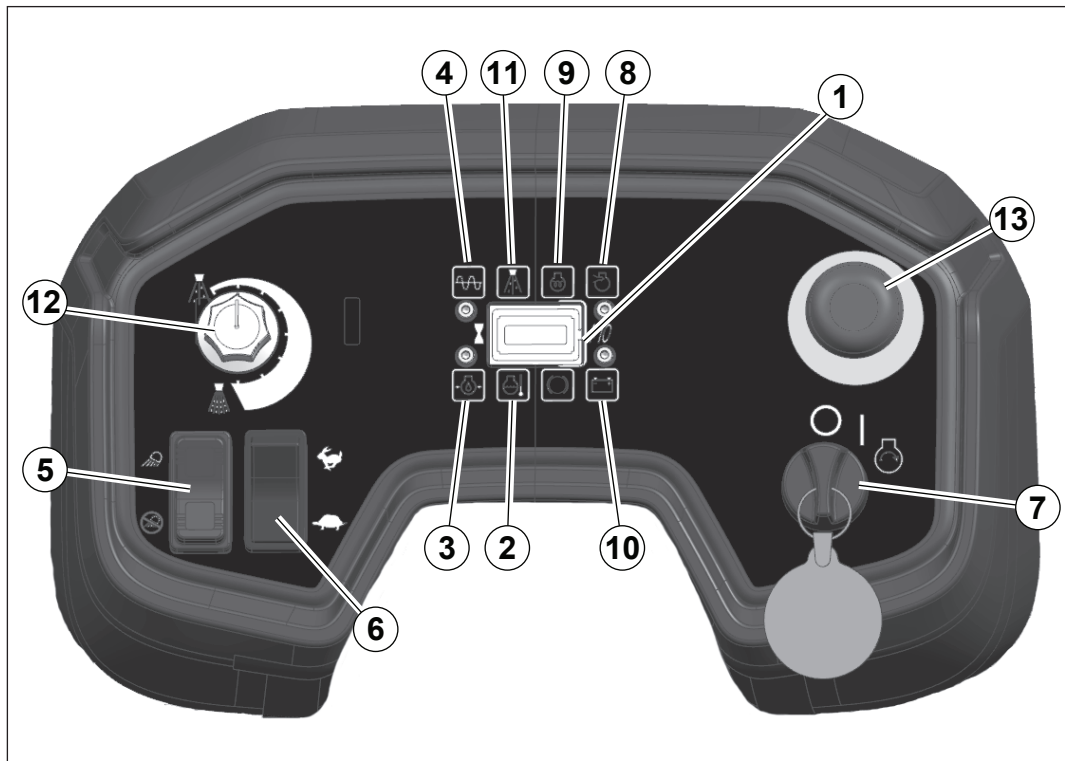

wc\_gr014587

Ref.	Item	Description
1	Hour meter	This instrument meters machine usage.
2	Engine coolant temperature indicator	This light flashes to indicate that the engine has overheated. <b>Note:</b> The drum vibration is immediately disabled when this light flashes. There is a 60-second delay before engine shutdown to allow the operator to drive off of the asphalt. <b>NOTICE:</b> Trace the cause of overheating and rectify the situation before operating the machine.
3	Low engine oil pressure indicator	This light illuminates when the ignition switch (7) is in the ON position and the engine is not running; it goes out once the engine has started. If the light illuminates when the engine is running, it indicates that the engine oil pressure is low. Do not operate the machine if this light is illuminated.
4	Vibration ON indicator	This indicator light illuminates to indicate that the vibration is on.
5	Lights switch (if equipped)	This switch controls power to the lights.
6	Throttle switch	This switch sets the position of the throttle, either high or low.
7	Start switch	This switch starts or stops the engine.
8	Air filter restriction indicator	This indicator light illuminates to indicate that the air filter needs to be changed.
9	Glow plugs indicator	This indicator light illuminates to indicate that the glow plugs are on.

Ref.	Item	Description
10	Battery indicator	This indicator light illuminates when the battery is not charging.
11	Water spray indicator	This indicator shows whether the water spray is off or on.
12	Water spray dial	This dial sets the frequency at which the water pump turns on and off.
13	Engine stop switch	This switch shuts down the engine. Pull the switch up to allow the engine to run.

## 6 Operation

### 6.1 Preparing the Machine for First Use

1. Make sure all loose packaging materials have been removed from the machine.
2. Check the machine and its components for damage. If there is visible damage, do not operate the machine. Contact your Wacker Neuson dealer immediately for assistance.
3. Take inventory of all items included with the machine and verify that all loose components and fasteners are accounted for.
4. Add fluids as needed and applicable, including fuel, engine oil, hydraulic oil, retardant, and battery acid.
5. Move the machine to its operating location.
6. Connect component parts not already attached.

### 6.2 Preliminary Checks

**Requirements** Machine on a flat, level surface

**Before starting**

Before starting the machine, check the following items:

- Engine coolant level (diesel only)
- Engine oil level
- Hydraulic oil level
- Fuel level
- Condition of oil cooler and radiator cooling fins
- Water level in tank

**NOTICE:** Top off the lubricating and hydraulic oil levels using products with the grades and specifications shown in the “Lubrication” table found in the *Technical Data* chapter of this Operator’s Manual. When doing so, use clean containers, funnels, etc., to avoid contamination.

**Before operating**

Before operating the machine:

- Check the machine for fluid leaks. Repair them before operating.
- Unlock the articulated steering joint.
- Adjust drum scraper position.
- Check the work area for obstructions. Remove all obstructions.
- Check that all handles, steps, and platforms are free of dirt, snow, grease, fuel, or anything else which might endanger operator safety.
- Allow the engine to warm up according to the following schedule:

Ambient Temperature	Time (min.)
Above 0°C (32°F)	5
Below 0°C (32°F)	15*

\* More time may be required if hydraulic controls are sluggish.

### 6.3 Recommended Fuel—Gasoline

#### Use of oxygenated fuels

The engine requires regular grade unleaded gasoline. Use only fresh, clean gasoline. Gasoline containing water or dirt will damage the fuel system. Consult the engine owner's manual for complete fuel specifications.

Some conventional gasolines are blended with alcohol. These gasolines are collectively referred to as oxygenated fuels. If you use an oxygenated fuel, be sure it is unleaded and meets the minimum octane rating requirement.

Before using an oxygenated fuel, confirm the fuel's contents. Some states and provinces require this information to be posted on the fuel pump.

The following is the Wacker Neuson approved percentage of oxygenates:

**ETHANOL** - (ethyl or grain alcohol) 10% by volume. You may use gasoline containing up to 10% ethanol by volume (commonly referred to as E10). Gasoline containing more than 10% ethanol (such as E15, E20, or E85) may not be used because it could damage the engine.

If you notice any undesirable operating symptoms, try another service station or switch to another brand of gasoline.

Fuel system damage or performance problems resulting from the use of an oxygenated fuel containing more than the percentages of oxygenates mentioned above are not covered under warranty.

### 6.4 Recommended Fuel—Diesel

Low temperatures cause diesel fuel to gel. Always use the proper fuel for the conditions. Follow the guidelines in the table below.

Lowest expected ambient temperature °F (°C)	Recommended fuel
Above 25 (-4)	#2 diesel plus additives (ultra low sulfur fuel only)
5 to 25 (-15 to -4)	
Below 5 (-15)	Winter-blend diesel (ultra low sulfur fuel only)

**NOTICE:** Do not use B20 or any other type of biodiesel fuel in this machine.



#### CAUTION

Fire hazard.

- ▶ Do not use gasoline, crankcase oil, or any oil containing gasoline.

## 6.5 Rollover Protection Structure (ROPS)

**Background** The machine is equipped with a rollover Protection Structure (ROPS). The ROPS is designed to protect the operator in a rollover accident. Depending on the machine model, the ROPS is either fixed (stationary) or foldable.

A foldable ROPS is equipped with two sets of hinge pins, or locking pins. This enables the ROPS to be folded either forward or backward as required for transportation or storage.



### WARNING

Crushing hazard. Without a ROPS, you may be crushed if the machine rolls or tips.

- ▶ Never operate the machine without the ROPS in place and securely fastened in the upright position.



### WARNING

Crushing/machine damage hazards. The ROPS is intended strictly to protect the operator during a rollover or tip-over incident and must not be used to lift the machine.

- ▶ Use only the designated lifting eyes to lift the machine. See *Lifting the Machine*.



### WARNING

Personal injury hazard. The ROPS is not a handhold for passengers. Passengers can be seriously injured or killed from falls, tip-overs, or rollover incidents.

- ▶ Do not allow anyone to ride on any part of the machine.

### Checking ROPS condition

Each month, check:

- The torque on all of the screws holding the ROPS in place
- The ROPS frame for rust, cracks, and any other damage

### Rules for reinstalling

When reinstalling the ROPS:

- Use the original nuts and bolts.
- Tighten the bolts to the specified torques.

**NOTICE:** Do not weld or drill into the ROPS. Drilling or welding on the ROPS will nullify the ROPS certification.

### Raising the ROPS

Perform the following procedure to raise the ROPS.



### WARNING

Pinching/crushing hazard.

- ▶ Keep fingers and extremities away from the pivot points when raising or lowering a foldable ROPS.

*This procedure continues on the next page.*



Continued from the previous page.

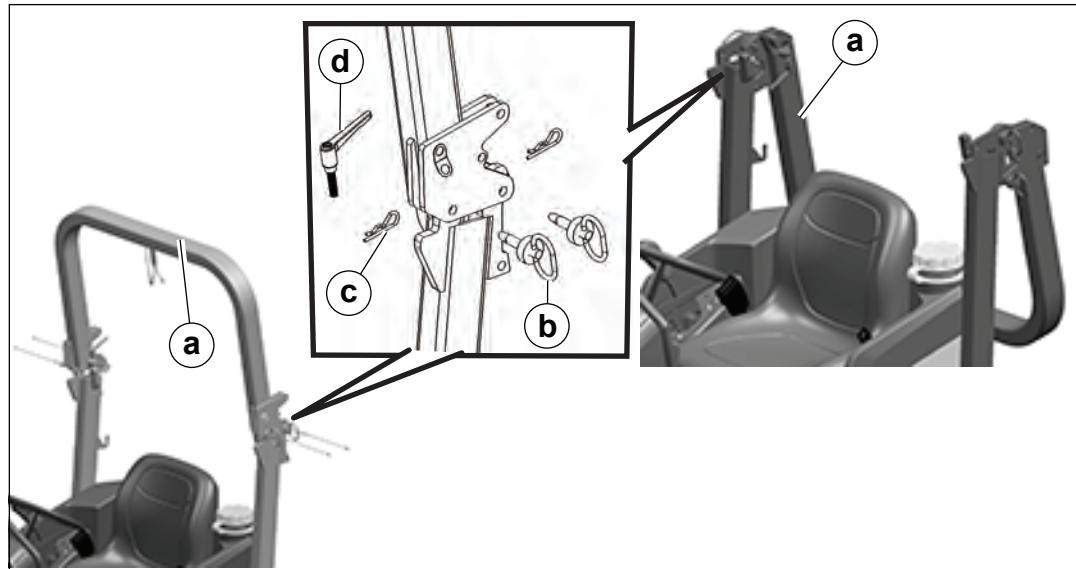

wc\_gr014310

1. Support the upper half of the ROPS (a) using a crane and suitable rigging capable of supporting 19 kg (42 lbs).



#### WARNING

Crushing hazard.

- ▶ Do not remove all cotter pins and locking pins from each side of the ROPS at the same time. One set of cotter pins and locking pins must always remain installed on each side of the ROPS during the raising process.

2. Each side of the ROPS is equipped with two locking pins (b) held in place with two cotter pins (c). Remove the appropriate cotter pins and pull out the corresponding locking pins.
  3. Lift the ROPS into the upright position.
  4. Insert the locking pins and secure them with the cotter pins.
  5. Tighten the adjusting handle (screw) (d) to reduce vibration.
- The ROPS is now in position and ready for service.

#### Lowering the ROPS

Follow the procedure below to lower the ROPS.

1. Support the upper half of the ROPS using a crane and suitable rigging capable of supporting 19 kg (42 lbs).
2. Remove the appropriate cotter pins and pull out the corresponding locking pins.
3. Gently lower the upper half of the ROPS.

**NOTICE:** When lowering the ROPS, do not drop the upper frame. Sudden impacts can weaken or damage the ROPS.

4. Insert the locking pins and secure them with the cotter pins.

## 6.6 Position of the Operator

Safe and efficient use of this machine is the operator's responsibility. Full control of the machine is not possible unless the operator maintains the proper working position at all times.

While operating this machine, the operator must:

- Be seated in the operator's seat facing forward
- Wear the seat belt, properly adjusted and latched
- Have both feet on the operator's platform
- Have one hand on the steering wheel at all times
- Have the other hand free to operate the controls as needed

## 6.7 Mounting and Dismounting the Machine

When climbing on and off the machine, maintain a three-point contact with the steps and the handholds.

Three-point contact can be:

- Two feet and one hand
- One foot and two hands

**NOTICE:** Do not use the control lever when mounting or dismounting the machine. Use only the designated handholds on the control column.

## 6.8 Operator Presence System

The machine is equipped with an "operator presence system." This system is part of the seat and senses the weight of an operator in the seat. During operation, the engine will shut down if the operator leaves the seat when the machine is not in neutral.

When the operator sits down again, the forward/reverse control must be placed in the neutral position before the engine can be started.

**Note:** A one-half second delay keeps the system from tripping when the machine passes over a bump.



### WARNING

Possibility of injury.

- ▶ Always wear the seat belt provided when operating the machine.
-

## 6.9 Starting, Operating, and Stopping the RD12A (Gasoline)

- Requirements**
- The machine is in serviceable condition and has been properly maintained.
  - There is fuel in the tank.



### DANGER

Asphyxiation hazard. Exhaust gases contain carbon monoxide and can kill in minutes.

- ▶ Do not start the engine in an enclosed space.

### Starting the machine

Perform the following procedure to start the machine.

1. Sit in the operator's seat and fasten the seat belt.
2. Apply the parking brake.
3. Set the forward/reverse control (a) in the NEUTRAL position.

**Note:** The roller will not start unless the forward/reverse control is in the NEUTRAL position.

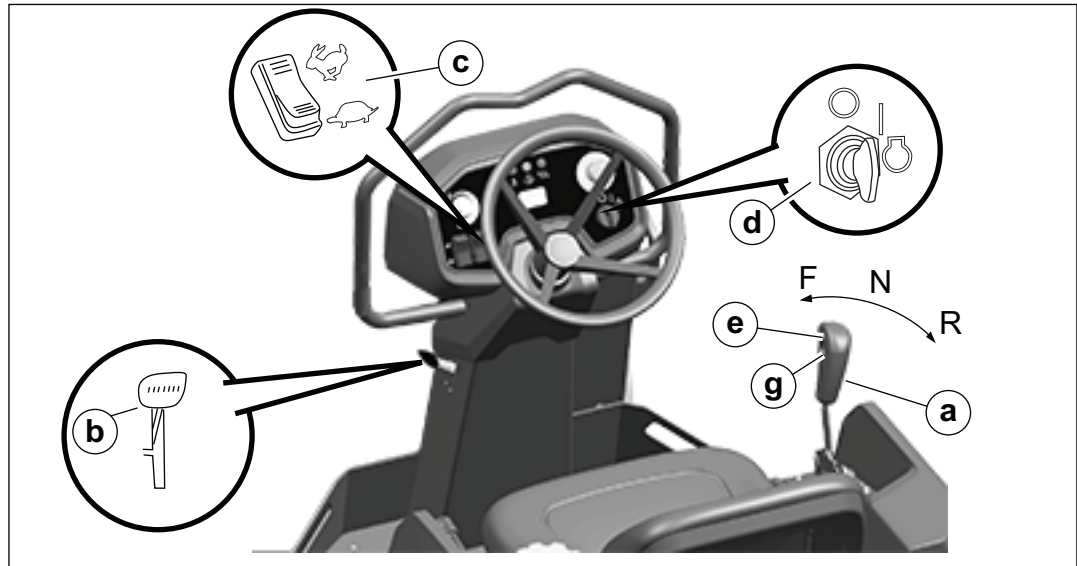

wc\_gr012262

4. If the engine is cold, move the choke lever (b) down into the CLOSED position. If the engine is warm, move the choke control up to the OPEN position.
5. Set the engine throttle switch (c) to the high (rabbit) position.

**NOTICE:** Do not crank the engine ignition switch for more than 15 seconds at one time. Longer cranking cycles could lead to starter damage.

6. Turn the start key (d) to the start position until the engine starts, then release the key.
7. Move the choke lever to the OPEN position as the engine warms up.
8. Set the engine throttle to the low position.

**Note:** Allow the engine to warm up for a few minutes before operating the roller.

*This procedure continues on the next page.*

*Continued from the previous page.*

**Operating the machine**

Perform the procedure below to operate the roller.

1. Before moving the machine, release the parking brake by lowering the brake lever.
2. Set the engine throttle to the high position. This ensures maximum travel speeds and will produce the best compaction results.

**NOTICE:** Operating the machine at slower engine speeds will reduce compaction, slow down machine functions.



---

**WARNING**

High noise levels. Prolonged exposure can damage your hearing.

- ▶ Wear appropriate hearing protection while operating this machine.
- 

3. Move the forward/reverse lever into FORWARD. The forward/reverse lever controls both the direction and speed of the machine. The farther forward the control is moved the faster the machine will travel.

**Note:** Use the control lever, rather than the throttle, to control the speed of the machine while compacting.

4. Press the vibration button on the forward/reverse lever to start vibration.
5. Press the water spray button on the forward/reverse lever to activate the water spray system.
6. Rotate the water spray dial to select the water flow frequency desired.

*This procedure continues on the next page.*

Continued from the previous page.

### Stopping the machine

1. Maneuver the machine to a flat surface with a suitable load bearing capacity.
2. Press the vibration button (e) to turn it off.
3. Set the forward/reverse control to the NEUTRAL position.

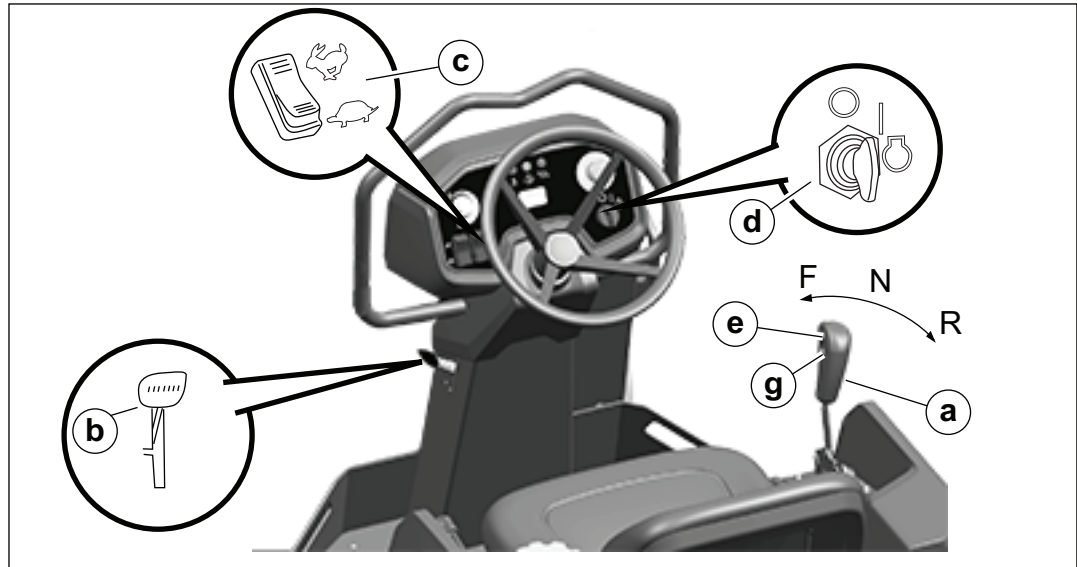

wc\_gr012262

4. Press the water spray button (g) to turn it off.
5. Set the engine throttle switch to the low (turtle) position and allow the engine to cool down.
6. Apply the parking brake. Always apply the parking brake before leaving the machine.

**Note:** The parking brake engages the rear drum only.



### WARNING

The vehicle constitutes a hazard or obstacle to traffic when parked.

- Mark the vehicle with signs, lights, and other warnings.

7. Turn the start key to the OFF position.
8. Secure the drums with wheel chocks to prevent unintentional movement.

## 6.10 Starting, Operating, and Stopping the RD12K (Diesel)

- Requirements**
- Machine is in serviceable condition and has been properly maintained
  - There is fuel in the tank



### DANGER

Asphyxiation hazard. Exhaust gases contain carbon monoxide and can kill in minutes.

- ▶ Do not start the engine in an enclosed space.

### Starting the machine

Perform the steps below to start the machine.

1. Sit in the operator's seat and fasten the seat belt.
2. Apply the parking brake.
3. Set the forward/reverse control (**a**) in the NEUTRAL position.

**Note:** The roller will not start unless the forward/reverse control is in the NEUTRAL position.

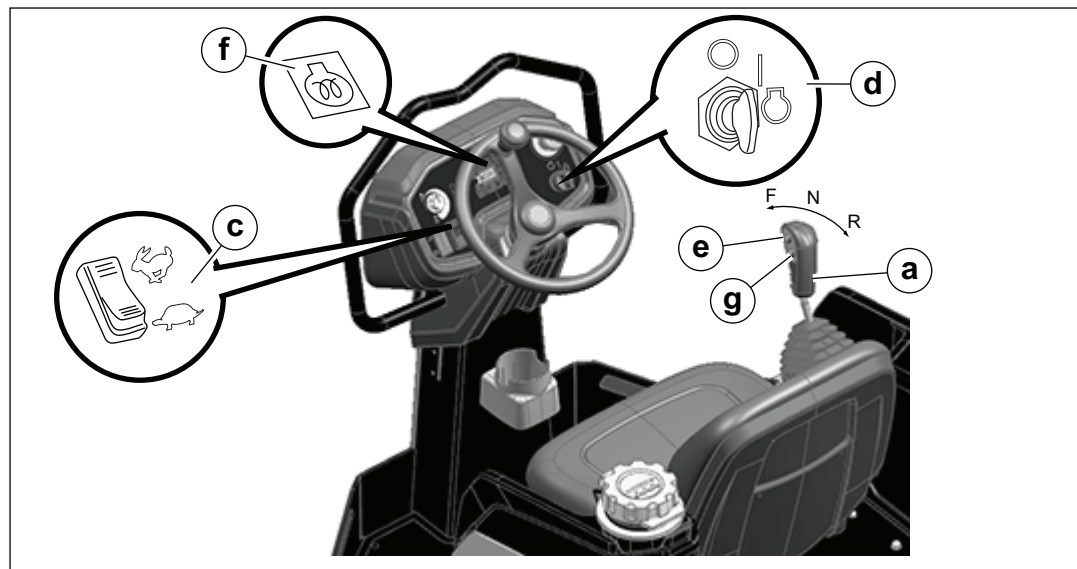

wc\_gr014718

4. Turn the start key (**d**) to the ON position. The glow plug indicator (**f**) will illuminate signifying the glow plugs are on. The glow plug indicator will stay on approximately five seconds at 0°C (32°F). **Do not** start the engine until the glow plug indicator light goes out.

**NOTICE:** Do not crank the engine ignition switch for more than 15 seconds at one time. Longer cranking cycles could lead to starter damage.

5. Turn the start key to the START position until the engine starts, then release the key.
6. Allow the engine to warm up for a few minutes before operating the roller.

*This procedure continues on the next page.*

*Continued from the previous page.*

**Operating the machine**

Perform the procedure below to operate the roller.

1. Before moving the machine, release the parking brake by lowering the brake lever.
2. Set the engine throttle to the high (rabbit) position. This ensures maximum travel speeds and will produce the best compaction results.

**NOTICE:** Operating the machine at slower engine speeds will reduce compaction, slow down machine functions, and may damage hydraulic components.



---

**WARNING**

High noise levels. Prolonged exposure can damage your hearing.

- ▶ Wear appropriate hearing protection while operating this machine.
- 

3. Move the forward/reverse lever into FORWARD. The forward/reverse lever controls both the direction and speed of the roller. The farther forward the control is moved the faster the machine will travel.

**Note:** Use the control lever, rather than the throttle, to control the speed of the machine while compacting.

4. Press the vibration button on the forward/reverse lever to start vibration.
5. Press the water spray button on the forward/reverse lever to activate the water spray system.
6. Rotate the water spray dial to select the water flow frequency desired.

*This procedure continues on the next page.*

*Continued from the previous page.*

## Stopping the machine

1. Maneuver the machine to a flat surface with a suitable load bearing capacity.
2. Press the vibration button **(e)** to turn it off.
3. Set the forward/reverse control **(a)** to the NEUTRAL position.

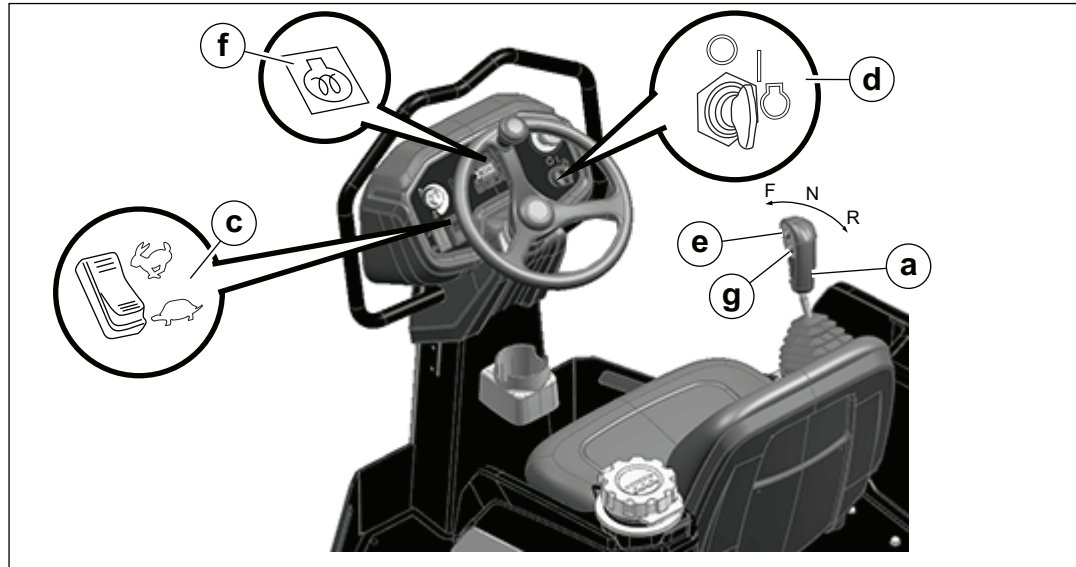

wc\_gr014718

4. Press the water spray button **(g)** to turn it off.
5. Set the engine throttle switch to the low (turtle) position and allow the engine to cool down.
6. Apply the parking brake. Always apply the parking brake before leaving the machine.

**Note:** *The parking brake engages the rear drum only.*



## WARNING

The vehicle constitutes a hazard or obstacle to traffic when parked.

- ▶ Mark the vehicle with signs, lights, and other warnings.

7. Turn the start key to the OFF position.
8. Secure the drums with wheel chocks to prevent unintentional movement.



## 6.11 Positioning the Scrapers

- Requirements**
- Machine shut down
  - Apply the parking brake

**Positions** Each drum has two scrapers (**a**, **b**). Scrapers prevent dirt and asphalt from sticking to and accumulating on the drum surface. They are spring loaded, and may be set in the travel position (**1**) or the scraping position (**2**) by moving the scraper off of or against the drum.

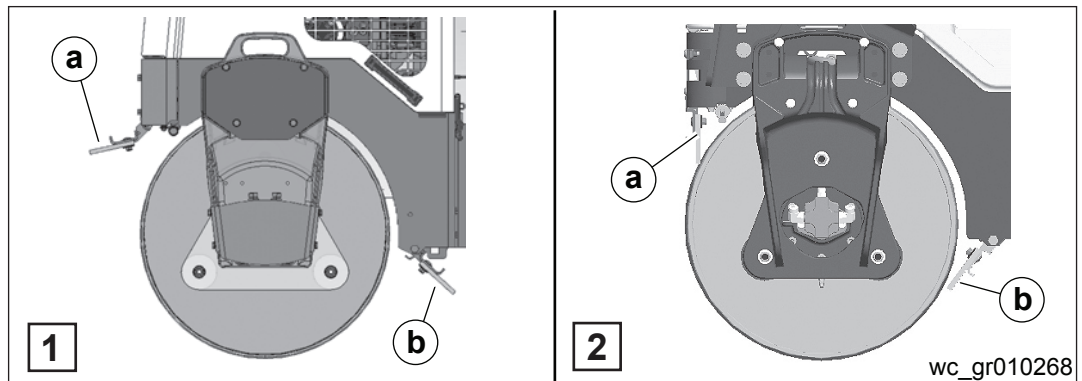

## 6.12 Using the Seat Belt

**Precaution** Always use the seat belt when operating the machine.

**To use** To use the seat belt:

1. Pull seat belt **(c)** out of the retractor in a continuous motion.

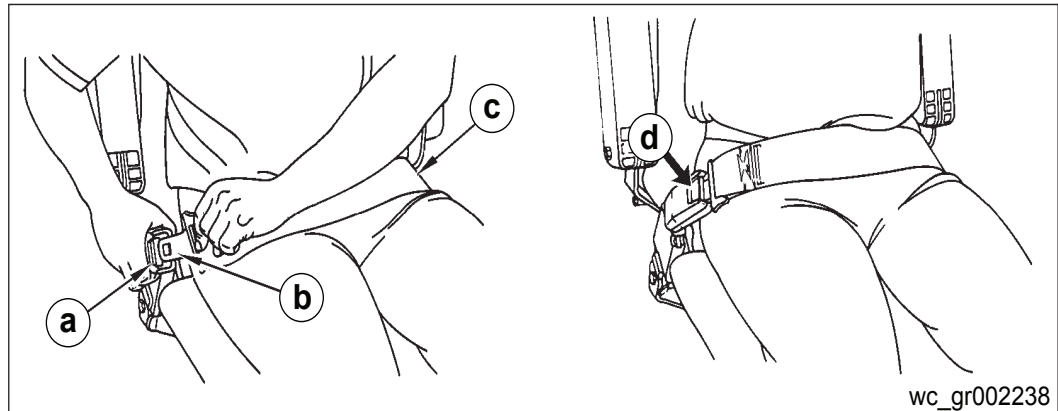

2. Fasten seat belt catch **(b)** into buckle **(a)**.
3. Position the seat belt low across the lap of the operator. The retractor will adjust the belt length, and the retractor will lock in place.
4. Push the release button **(d)** on the buckle in order to release the seat belt. The seat belt will automatically retract into the retractor.



### CAUTION

Possibility of injury. A worn seat belt may not protect the operator in an emergency.

- Replace the seat belt every three years.

## 6.13 Using the Forward/Reverse Lever

**Background** Both roller drums are driven. An infinitely variable displacement pump drives the hydraulic motors fitted to each drum. The machine moves forward or in reverse by using the forward/reverse lever located to the side of the operator's seat.

**Travel direction** Move the forward/reverse lever into FORWARD (**f**) or REVERSE (**r**) according to the direction of travel desired.

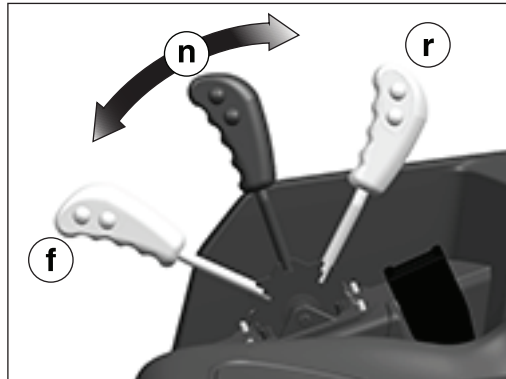

wc qr014304

To change direction of travel from FORWARD to REVERSE or vice versa:

1. Move the forward/reverse lever to the "N" NEUTRAL position (**n**).
2. Allow the machine to come to a complete stop.
3. Move the forward/reverse lever in the direction desired.

**Note:** *In order to comply with safety standards, the machine has a device which only enables starting of the engine when the forward/reverse lever is in the neutral position.*

**Travel speed**

- Travel speed varies from "ZERO" to a permitted maximum of 8 kph (5 mph).
- The farther forward or reverse the forward/reverse lever is positioned, the faster the roller will travel.
- Travel speed is the same in both FORWARD and REVERSE.

**Note:** *When negotiating slopes, keep the forward/reverse lever at minimum travel speed.*

**Braking** The forward/reverse lever can be used as an engine brake. Shifting the forward/reverse lever to the neutral position stops the machine.

**Operator presence system** The machine is equipped with an operator presence system. The system prevents the machine from moving forward or in reverse unless the operator is seated. The operator should remain seated at all times.

### 6.14 Using the Vibration System

**Background** The machine has an exciter in the front drum. The exciter is driven by a gear-type hydraulic motor. The exciter motor is fed by a fixed-displacement, gear-type hydraulic pump.

**Starting and stopping vibration**

To start vibration, press button **(a)**.

When vibration is active, the vibration ON indicator **(b)** will illuminate.

Vibration can be activated while operating in either forward or reverse, and will remain active until button **(a)** is pressed again.

To stop vibration, press button **(a)** again.

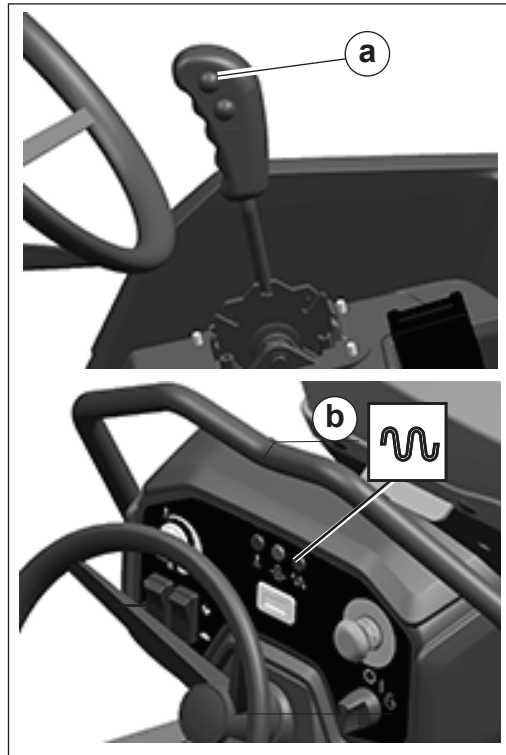

wc\_gr014305

**Using vibration**

Vibration remains active even when the forward/reverse control is in NEUTRAL.

## 6.15 Using the Water Spray System

### Water spray controls

Water from the tank is fed to the spray bars by an electric pump. A water spray button **(a)**, located on the travel lever next to the vibration switch, controls the water pump motor. A water spray dial **(b)** controls the water flow frequency.

To operate the water spray controls:

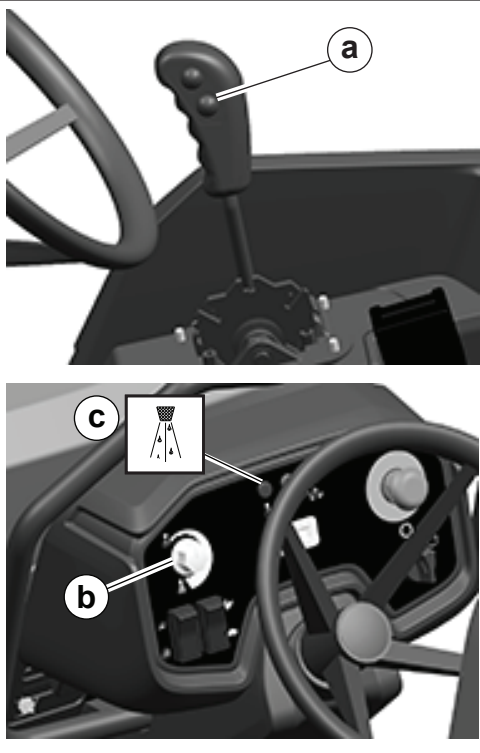
<p>To start the water spray, press button <b>(a)</b>.</p> <p>When the water spray is active, the water spray indicator <b>(c)</b> will illuminate.</p>	
<p>To stop the water spray, press button <b>(a)</b> again.</p>	
<p>Water spray dial: Rotate the water spray dial <b>(b)</b> clockwise to increase water spray frequency.</p> <p>Rotate the water spray dial counterclockwise to decrease water spray frequency.</p>	

wc\_gr014306

### Guidelines when using

When using the water spray system:

- Check that the tank is full of water.
- Use only clean water. Dirty water, even when filtered, can clog the system.
- Keep the water system clean and well maintained. See *Maintenance*.
- If spray does not begin immediately when the system is turned on, it may be necessary to clean the spray bars. See *Maintenance*.

## Water check valve

The water spray system includes a water check valve (**d**) located between the water pump and the spray bars. This water check valve prevents water from draining out of the tank through the water system.

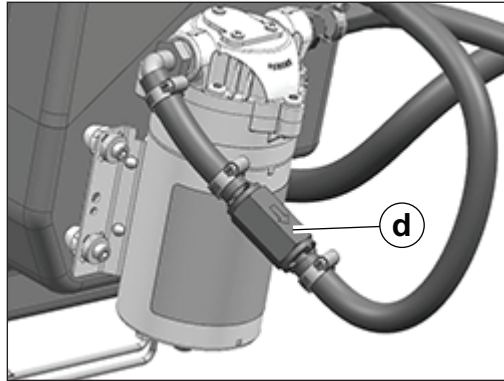

wc\_gr015174

## 6.16 Using the Backup Alarm (if equipped)

### Location

The backup alarm (**a**) is located on the rear of the machine.

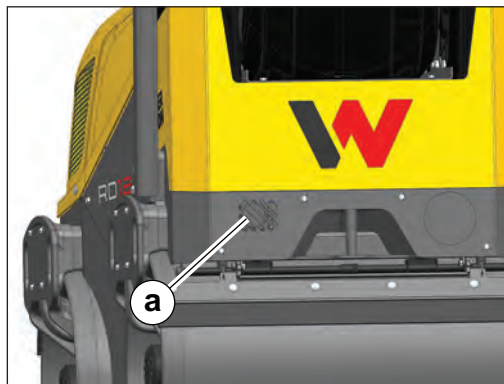

wc\_gr014990

### Operation

Start the engine and move the forward/reverse lever to the reverse position. The backup alarm should sound immediately. The backup alarm will continue to sound until the forward/reverse lever is moved to the neutral position or to the forward position.

**Note:** *If the backup alarm does not sound, make the necessary repairs before using the roller.*

## 6.17 Using the Work Lights (if equipped)

**Location** Two work lights **(a)** are located on the front of the machine, and one work light **(b)** is located on the rear of the machine.



wc\_gr014988

**Operation** While the machine is running, press the top of the work light switch **(c)** to turn the work lights on. Press the bottom of the work light switch to turn the work lights off.



wc\_gr014989

## 6.18 Using the Manual Parking Brake

**Background** To hold the machine in a stopped position (parked), there is a mechanical parking brake on the rear drum. The engine automatically shuts off if the operator leaves the seat when the drive control lever is not in neutral, but the parking brake must be applied manually.

**Engaging and releasing** To apply the parking brake, pull the brake lever (a) up until the brake pad engages the rear drum. Always apply the parking brake before leaving the machine. To release the parking brake, lower the brake lever. The forward/reverse control should be in the NEUTRAL position when the parking brake is released.

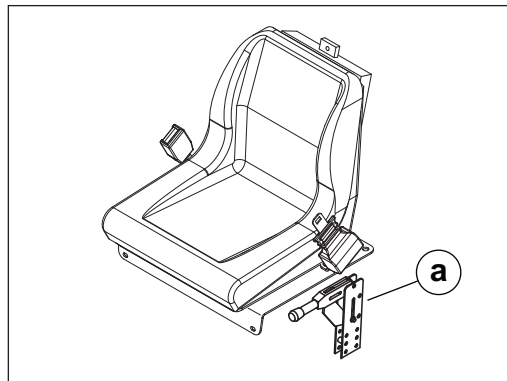

wc\_gr012266

The parking brake is connected to the brake pads and can be adjusted by turning the knob on the end of the handle. See section *Parking Brake Adjustment*.

**Emergency use**

**NOTICE:** Under normal operating conditions, do not use the parking brake when the machine is moving. Using the parking brake while the machine is moving may cause excess wear on the brake.

Only use the parking brake to stop the machine when the machine is moving during an emergency condition. For example:

- During failure of the main hydraulic braking system (no braking action when the forward/reverse control is moved to the neutral position)
- In a runaway condition traveling down a slope



## 6.19 Parking Brake Adjustment

The parking brake is located behind the rear drive motor drum support, and is used to prevent the roller from moving when the engine is turned off.

Adjust the brake for proper holding force as follows:

1. Unscrew the brake lever knob (a) until the brake can be applied with moderate force (approx. 30 lbs.).
2. Start the roller on level ground and try to travel forward and reverse with the brake applied. If the roller drives through the brake, stop machine, tighten the lever knob one turn and repeat the process.
3. When the machine no longer moves with the brake set, stop the machine, turn the knob one more turn, and the brake is properly set.

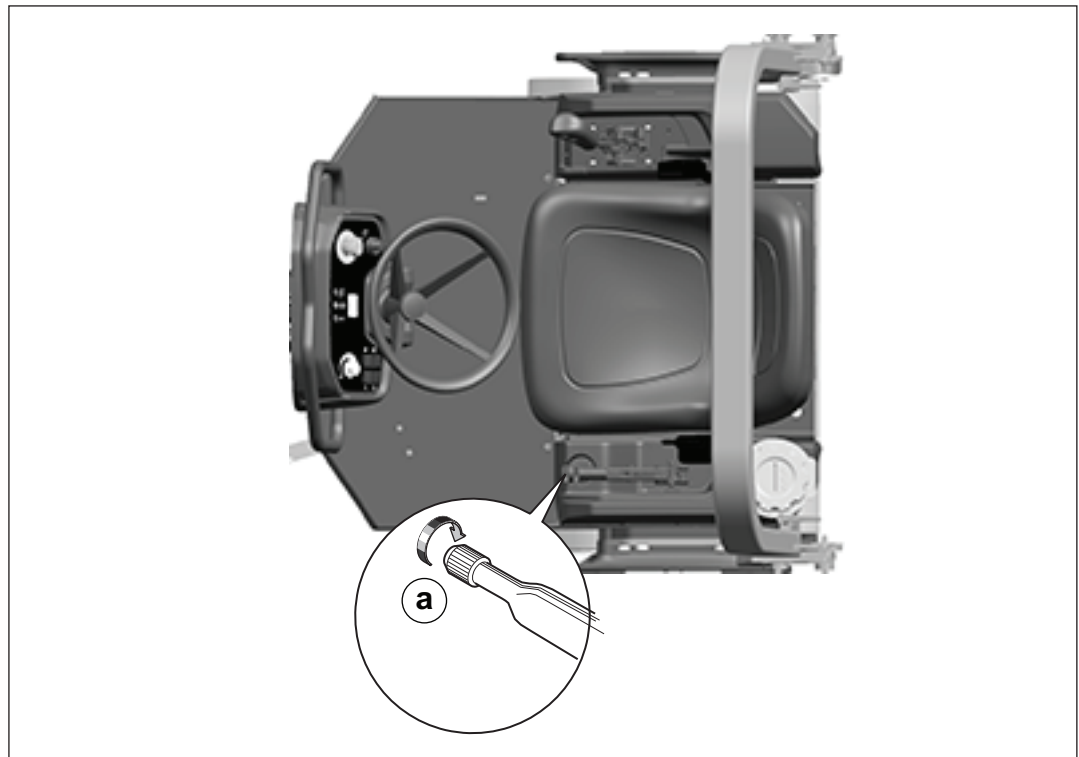

wc\_gr002953

## 6.20 Avoiding the Danger Zone

**Description** A “danger zone” is an area near a machine where a person can be seriously injured if struck by, or caught between, moving parts of the machine.

On this machine, the danger zone specifically refers to the area near the articulated steering joint between the front and rear frames (**a**). The danger zone is identified with safety labels (**b**) on both sides of the front frame.

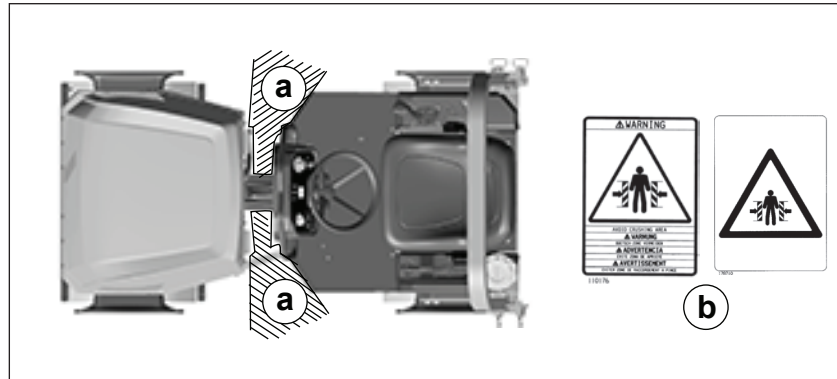

### Avoiding injury

Obey the instructions below to avoid injury within the danger zone.

- ▶ Make sure that the safety labels are present and clearly visible on both sides of the articulated steering joint.
- ▶ Before operating the machine, instruct all personnel in the vicinity to stay away from the machine while it is being operated.
- ▶ While operating the machine, remain aware of people moving in the work area. Be ready to react to these movements if necessary.
- ▶ Lock the articulated steering joint before servicing the machine. See topic *Locking and Unlocking the Articulated Steering Joint*.

## 6.21 Adding Ballast to Rear Drum

The rear drum can be filled with ballast to provide weight. Add ballast through the plug opening (a).

<b>Drum Capacity</b>	99 liters (26 gal.)
<b>Added Weight (water ballast)</b>	98 kg (217 lb)

If water is used as ballast in areas where temperatures are below freezing, add antifreeze or drain the drum after use.

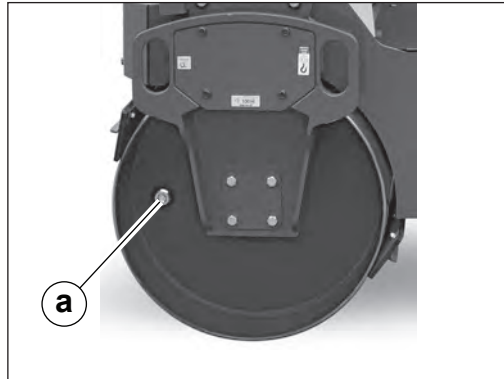

wc\_gr015173

## 6.22 Emergency Shutdown Procedure

If a breakdown/accident occurs while the machine is operating, follow the procedure below.

1. Press the engine stop switch (a).

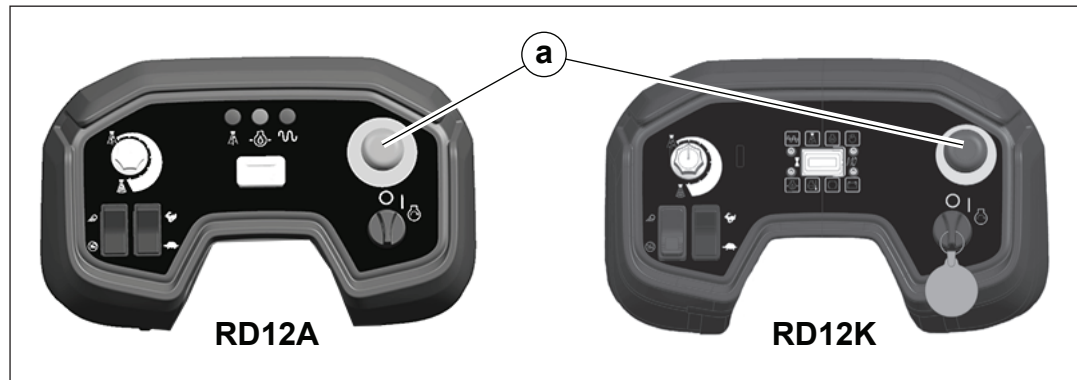

wc\_gr015172

Activate the engine stop switch by pushing the button. Pushing the engine stop switch:

- Turns off (opens) the main circuit breaker
- Turns off the ignition system relay (RD12A only)
- De-energizes the engine stop solenoid (RD12K only)
- Cuts power to the fuel solenoid
- Stops the engine

The engine stop switch will remain activated until the switch is pulled up.

**Note:** Press the engine stop switch only in the case of an actual emergency where the machine must be stopped immediately. The start switch can also be used to stop the engine at any time.

2. Apply the parking brake.
3. Allow the machine to cool.
4. Using appropriate equipment, return the machine to an upright position if tipped over.
5. Contact the rental yard or machine owner for further instructions.

## 6.23 Machine Stability



### WARNING

Crushing hazards. Certain job site conditions or operating practices may adversely affect machine stability.

- ▶ Follow the instructions below to reduce the risk of tipping or falling incidents.

### Surface conditions

Pay attention to changing surface conditions while operating the machine. Adjust speed and travel direction as necessary to maintain safe operation.

- Machine stability and traction may be severely reduced when operating on uneven or rough terrain, rocky soils, or wet or loosely packed surface material.
- The machine may suddenly tip, sink, or fall when moved onto surfaces that have been newly filled with earth.

### Steering angle

An articulated roller is more likely to tip when moving off an elevated surface if the machine is turned away from the edge.

- ▶ As shown in the illustration on the right, always turn the machine toward the edge when moving off an elevated surface.

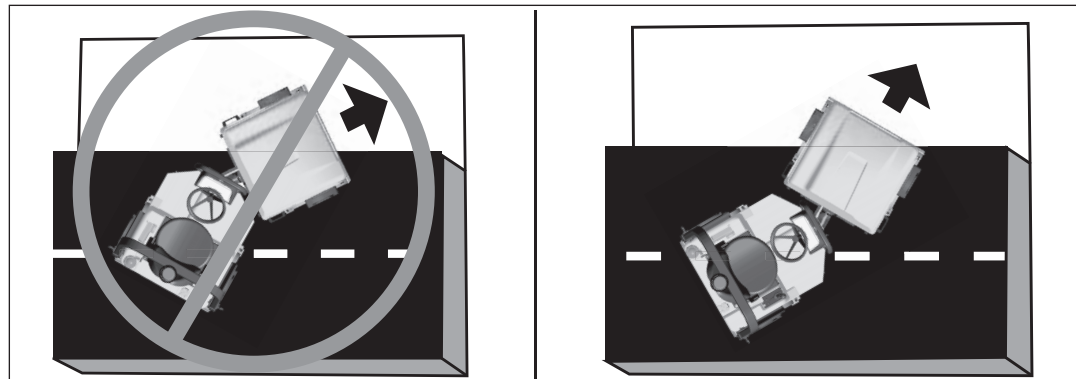

wc\_gr007042

### Travel speed

A fast moving machine is more likely to tip or fall over while making turns or changing direction.

- ▶ Reduce travel speed before turning the machine.

### Drum overhang

The machine can tip suddenly if more than half of the drum width extends beyond the edge of the elevated surface.

- ▶ Reduce travel speed and watch the drum position carefully when operating along the edge of an elevated surface.
- ▶ Keep as much of the drum on the elevated surface as possible.

### Vibrating on a compacted surface

Activating the vibration system on a fully compacted surface may cause the drums to rebound and momentarily lose contact with the ground. If this occurs while the machine is on an incline, the machine may slide.

- ▶ If the drums rebound on the compacted surface, stop vibration entirely.

6.24 Operating on Slopes

**Background** When operating on slopes or hills, special care must be taken to reduce the risk of personal injury or damage to the machine.

**Procedure** Always operate the machine up and down slopes rather than from side to side. For safe operation and for protection of the engine, continuous duty use should be restricted to slopes of 17° (30% grade) or less.



**WARNING**

Crushing hazard. Never operate the machine sideways on slopes. The machine may tip or roll over even on stable ground.

- ▶ Operate the machine straight up and down slopes.

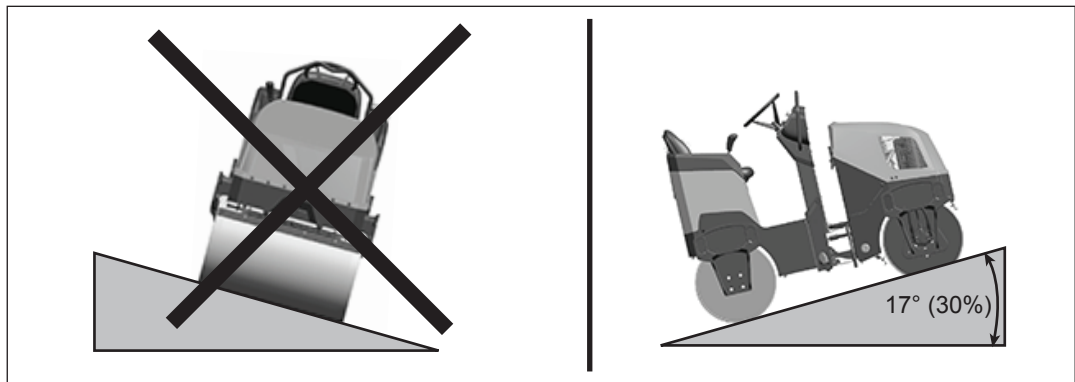

wc\_gr014309

**Surface conditions**

Pay attention to changing surface conditions while operating the machine. Adjust speed and travel direction as necessary to maintain safe operation.

- Machine stability and traction may be severely reduced when operating on uneven or rough terrain, rocky soils, or wet or loosely packed surface material.
- The machine may suddenly tip, sink, or fall when moved onto surfaces that have been newly filled with earth.

## 7 General Maintenance



---

**WARNING**

A poorly maintained machine can malfunction, causing injuries or permanent damage to the machine.

- ▶ Keep the machine in safe operating condition by performing periodic maintenance and making repairs as needed.
- 

### 7.1 Maintaining the Emission Control System

For machines sold in North America:

Normal maintenance, replacement, or repair of emission control devices and systems may be performed by any repair establishment or individual; however, warranty repairs must be performed by a dealer/service center authorized by Wacker Neuson. The use of service parts that are not equivalent in performance and durability to authorized parts may impair the effectiveness of the emission control system and may have a bearing on the outcome of a warranty claim.

**7.2 Periodic Maintenance Schedule**

The table below lists basic machine and engine maintenance. Tasks designated with check marks ✓ may be performed by the operator. Tasks designated with square bullet points ■ require special training and equipment.

Refer to the engine owner’s manual for additional information.

	Daily before starting	Every 100 hours	Every 500 hours	Every 1000 hours
Check the external hardware.	✓			
Check the water filter.	✓			
Check the level of hydraulic oil.	✓			
Check the condition of hydraulic hoses and connections.	✓			
Check the electrical wiring and connections.	✓			
Check operation of the parking brake and make sure it engages.	✓			
Check operation of the neutral safety switch.	✓			
Check the seat belt.	✓			
Grease the articulated steering joint tie rod.		■		
Grease the rear drum drive bearings.		■		
Grease the exciter bearings.		■		
Grease the steering cylinder ends.		■		
Check the battery.		■		
Clean the scraper bars.		✓		
Clean the water filter.		✓		
Change the hydraulic system return line filter. <sup>1</sup>			■	
Clean the battery terminals.			■	
Change the hydraulic oil.				■

<sup>1</sup>Replace hydraulic system return line filter after first month or 100 hours of operation.



### 7.3 Opening the Floor Plate

#### Overview

The floor plate is hinged and can be tilted to provide access to the water pump, the water filter, the battery, the hydraulic hoses, the steering cylinder, and the Operator's Manual. The floor plate has a lifting cylinder that holds the floor plate in the open position.

#### Raising the floor plate

Perform the procedure below to tilt the floor plate.

1. Standing on either side of the machine at the articulated steering joint (a), grab the floor plate handle (b) and lift upward. The lifting cylinder (c) assists and holds the floor plate (d) in the open position.



wc\_gr015025

2. Perform necessary maintenance work.

#### Lowering the floor plate

Perform the procedure below to lower the floor plate.

#### CAUTION

Pinching/crushing hazard. The floor plate is heavy enough to pinch or crush fingers or other parts of the body.

- Always grab the floor plate only by the handle. Lower the floor plate slowly, making sure there is nothing in the way that would prevent closing.

1. From either side of the machine, grab the floor plate handle.
2. Push down on the floor plate handle.

## 7.4 Checking the Seat Belt

- Requirements**
- Turn off the engine.
  - Apply the parking brake.
- 

**When** Daily, before starting the machine.

---

**Procedure** Perform the procedure below to inspect the seat belt.

1. Check the seat belt mounting hardware (**a**) for wear and damage.
  - Replace damaged hardware.

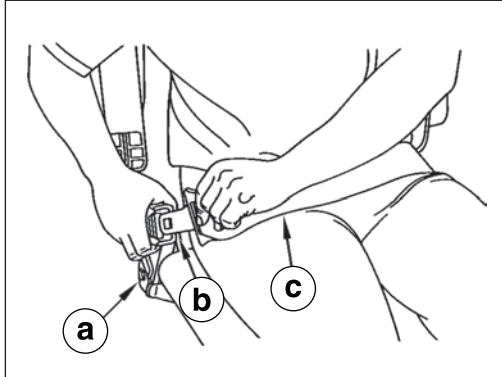

wc\_gr004781

2. Check the buckle (**b**) for wear and damage.
  - Replace the seat belt if the buckle is damaged.
3. Inspect the seat belt (**c**) for wear and damage.
  - Replace the seat belt if it is damaged.

**Note:** Replace the seat belt every three years even if none of the components show visible wear or damage.

## 7.5 Maintaining the Seat and Seat Belt

**Background** In order for the seat and seat belt to operate safely and properly over a long period of time, periodic maintenance and occasional repairs are necessary. Poorly maintained equipment can become a safety hazard.

---

**Maintaining the seat and seat belt**

- Keep the seat clean. Dirt, dust, or harsh chemicals can damage the upholstery. Repair holes or tears immediately.
- If necessary, clean the seat belt with a mild soap solution. Do not use chemical cleaners, as they will damage the fabric.
- Replace the seat belt immediately if it becomes worn or damaged. Otherwise, replace the seat belt every three years.

## 7.6 Checking the Water Filter

**When** Check the water filter daily before operating the machine. Daily checks are especially important if the available water supply is cloudy or dirty.

**Location** The water filter is located along the centerline of the machine beneath the floor plate. The floor plate must be opened to access the water filter.

**Requirements**

- Turn off the engine.
- Apply the parking brake.
- Open the floor plate (see *Opening the Floor Plate*).

**Procedure** Inspect the water filter (**a**) according to the checklist below.

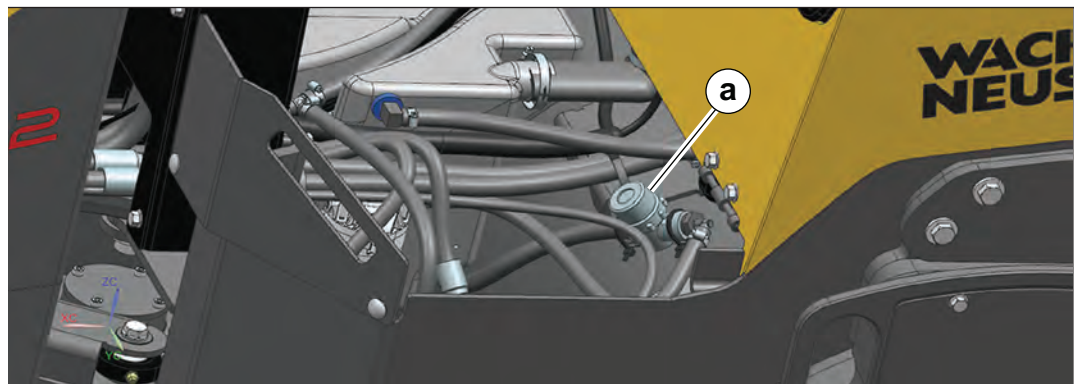

wc\_gr015029

Clean or replace the water filter if any of the following conditions exist:

- Cup is missing, damaged, cracked, or chipped
- Strainer is damaged or missing
- Hose connections are loose or leaking
- Cup is filled with sediment or dirt

## 7.7 Cleaning the Water Filter

**When** Clean the water filter every 100 hours, or more often if the available water supply is cloudy or dirty.

**Location** The water filter is located along the centerline of the machine beneath the floor plate. The floor plate must be opened to access the water filter.

- Requirements**
- Turn off the engine.
  - Apply the parking brake.
  - Drain the water tank.
  - Open the floor plate (see *Opening the Floor Plate*).

**Cleaning the water filter** Perform the steps below to clean the water filter (a).

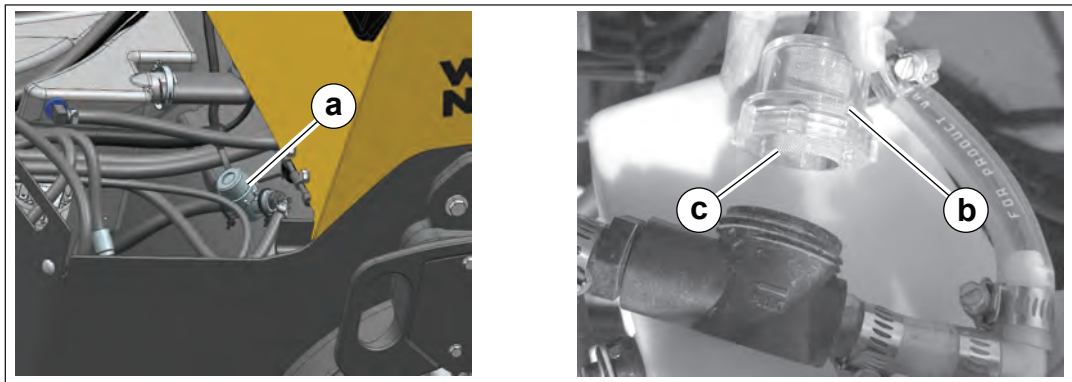

wc\_gr015031

1. Unscrew the cup (b) and remove the strainer (c).
2. Empty the cup.
3. Rinse the cup and strainer thoroughly with clean water to remove sediment and dirt.
4. Install the strainer in the cup, making sure that the strainer is properly seated inside the base of the cup.
5. Install the cup and hand-tighten.

## 7.8 Greasing the Fittings

See *Technical Data* for grease quantity and type.

- Requirement**
- Turn off the engine.
  - Remove the ignition key.
  - Apply the parking brake.

**When** Every 100 hours of service.

### Articulated steering joint tie rod

The articulated steering joint tie rod is equipped with grease fittings **(a)** on either end for lubrication. The main articulation bearing is fully sealed and requires no maintenance.



### WARNING

Pinching hazard.

- ▶ To avoid being pinched by the machine halves, set the lockarm before greasing the articulated steering joint or steering cylinder.

### Rear drum drive bearings

The rear drum drive bearings are equipped with a grease fitting **(b)** located at the center of the drum behind the right rear drum support.

### Exciter bearings

The exciter bearings are grease lubricated. There are two grease fittings **(c)**, one on each side of the machine, located behind the front drum supports.

### Steering cylinder ends

The steering cylinder ends are located under the operator's platform. There is a grease fitting at each end of the cylinder **(d)**. Access the fitting nearest the rear of the machine through the floor plate.

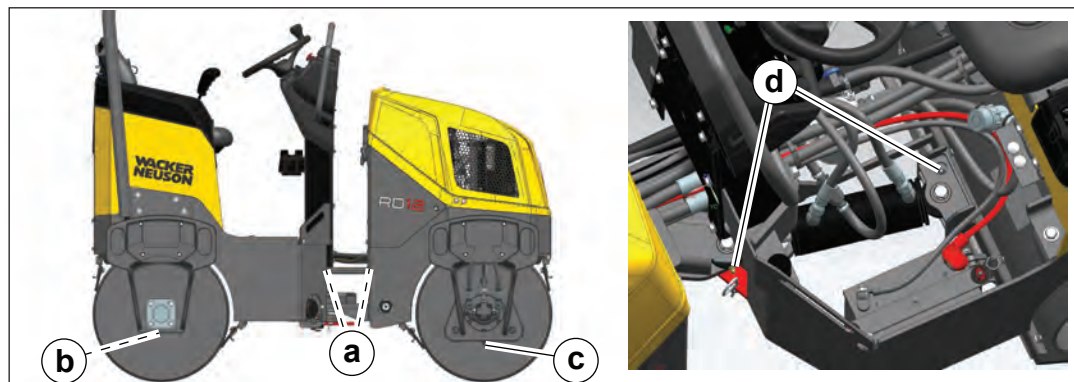

wc\_gr015030

7.9 Battery



**WARNING**

Explosion hazard. Batteries can emit explosive hydrogen gas.

- ▶ Keep all sparks and flames away from the battery.
- ▶ Do not short-circuit battery posts.



**WARNING**

Battery fluid is poisonous and corrosive.

- ▶ In the event of ingestion or contact with skin or eyes, seek medical attention immediately.

**Location** The battery on this machine is located on the left side of the machine under the floor plate.

**Disconnecting** To completely disconnect the battery (for example, when removing it):

1. Stop the machine and shut down the engine.
2. Place all electrical switches in the OFF position.
3. Disconnect the negative battery cable from the battery.
4. Disconnect the positive battery cable from the battery.

**Connecting** To connect the battery:

1. Connect the positive battery cable to the battery.
2. Connect the negative battery cable to the battery.

**Maintaining**

- Keep battery terminals clean and connections tight.
- When necessary, tighten the cables and grease the cable clamps with petroleum jelly.
- Maintain the battery at full charge to improve cold weather starting.

**Precautions** Observe the following precautions to prevent serious damage to the electrical system:

- Do not disconnect the battery while the machine is running.
- Do not attempt to run the machine without a battery.
- Do not attempt to jump-start a machine.
- In the event that the machine has a discharged battery, either replace the battery with a fully charged battery or charge the battery using an appropriate battery charger.

Dispose of discharged batteries in accordance with local environmental regulations.



## 7.10 Hydraulic System Cleanliness

Keeping the hydraulic oil clean is a vital factor affecting the service life of hydraulic components. Oil in hydraulic systems is used not only to transfer power, but also to lubricate the hydraulic components used in the system. Keeping the hydraulic system clean will help avoid costly downtime and repairs.

Major sources of hydraulic system contamination include:

- Particles of dirt introduced when the hydraulic system is opened for maintenance or repair
- Contaminants generated by the mechanical components of the system during operation
- Improper storage and handling of hydraulic oil
- Use of the wrong type of hydraulic oil
- Leakage in lines and fittings

To minimize hydraulic oil contamination:

- Clean hydraulic connections before opening the lines. When adding oil, clean the hydraulic tank filler cap and surrounding area before removing it.
- Avoid opening the pumps, motors, or hose connections unless absolutely necessary.
- Plug or cap all open hydraulic connections while servicing the system.
- Clean and cover the containers, funnels, and spouts used to store and transfer the hydraulic oil.
- Change the hydraulic filters and oils at the recommended service intervals.

## 7.11 Hydraulic Oil Requirements

Wacker Neuson recommends the use of a good petroleum-based, anti-wear hydraulic oil in the hydraulic system of this equipment. Good anti-wear hydraulic oils contain special additives to reduce oxidation, prevent foaming, and provide for good water separation.

When selecting hydraulic oil for your machine, be sure to specify anti-wear properties. Most hydraulic oil suppliers will provide assistance in finding the correct hydraulic oil for your machine.

Avoid mixing different brands and grades of hydraulic oils.

Most hydraulic oils are available in different viscosities.

The SAE number for an oil is used strictly to identify viscosity—it **does not** indicate the type of oil (engine, hydraulic, gear, etc.).

When selecting a hydraulic oil be sure it matches the specified SAE viscosity rating and is intended to be used as a hydraulic oil. See section *Technical Data—Lubrication*.

## 7.12 Checking the Hydraulic Oil Level

A hydraulic oil level sightglass (a) is located on the side of the hydraulic fluid reservoir.

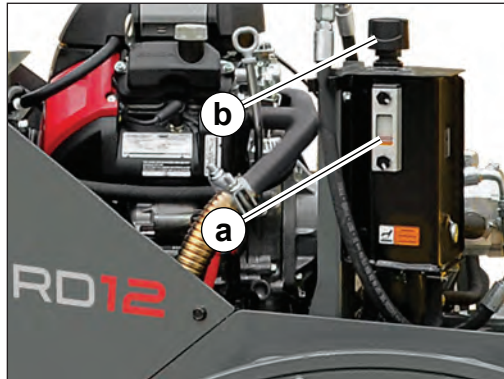

wc\_gr015028

While the machine is turned off, check that the hydraulic oil level is between the minimum and the maximum levels in the sightglass. If it is not, add oil through the filler port (b) inside the engine compartment. Use only clean hydraulic oil.

Thoroughly clean the top of the filler cap before removing it from the tank. Care should be taken to prevent small dirt particles from entering the system.

If hydraulic oil continually needs to be added, inspect hoses and connections for possible leaks.

## 7.13 Changing the Hydraulic Oil and Filter

Set all controls in neutral, stop the engine, and allow the engine and fluids to cool before performing this procedure.

All oils eventually shear or thin out with use, reducing their lubricating ability. In addition, heat, oxidation, and contamination may cause the formation of sludge, gum, or varnish in the system. For these reasons, it is important to change the hydraulic oil at specified intervals. See *Maintenance Schedule*.

1. Remove the filler cap from the top of the hydraulic tank.
2. Remove the drain hose from the clip, and direct the hose toward the front corner of the machine.
3. Remove the drain cap on the drain hose and allow the hydraulic fluid to drain.  
**Note:** *In the interests of environmental protection, place plastic sheeting and a container under the machine to collect the liquid which drains off. Dispose of this liquid properly.*
4. Unscrew the return line filter and replace the filter cartridge.
5. Install the drain cap on the drain hose and tighten.
6. Replace the drain hose into the clip.
7. Fill the hydraulic tank through the filler port with clean hydraulic fluid.
8. Bleed the hydraulic system. See section *Bleeding the Hydraulic System*.



## 7.14 Bleeding the Hydraulic System

**Overview** Bleeding trapped air from the hydraulic system is necessary each time the drive system or hydraulic system is opened up. Trapped air bubbles can cause equipment malfunctions or erratic performance.

---

**Procedure** Perform the procedure below to bleed trapped air from the exciter circuit and the drive circuit.

1. Fill the hydraulic system with clean hydraulic oil until it is at the maximum level in the sightglass. Do not reuse used hydraulic oil.
2. Place forward/reverse control in the NEUTRAL position.
3. Start the engine and run the machine at idle until the hydraulic oil level stabilizes.
4. Add hydraulic oil until it is at the maximum level and repeat as needed.
5. To bleed air from the exciter circuit:
  - a. Turn the vibration on.
  - b. Run the machine for 3–4 minutes.
  - c. Turn the vibration off, increase the engine speed to full, and turn the vibration on.
  - d. Check the hydraulic oil level and add oil as needed.
6. To bleed air from the drive circuit,
  - a. Slowly move the travel control lever back and forth, from forward to reverse, allowing the machine to roll back and forth slightly.
  - b. Switch the engine to high idle for 15–20 seconds. Return the engine to low idle for 1 minute. Repeat this process 2–3 times to bleed the remaining air from the hydraulic lines.
  - c. Check the hydraulic oil level and add oil as needed.
7. After returning to normal operation, check the hydraulic oil level again and add oil as needed.

### 7.15 Checking the Neutral Switch

**Requirement** Apply the parking brake.

**When** Every 10 hours of service or daily

**Procedure** Perform the procedure below to check the neutral switch.



**WARNING**

Crush hazard. The machine may lurch forward if the neutral switch is out of adjustment while making this test.

► Be sure the area is clear of all personnel and equipment before making this test.

1. Turn off the engine.
2. Apply the parking brake.
3. Move the forward/reverse lever to the FORWARD position.
4. Hold the engine start switch in the START position.
5. Slowly move the forward/reverse lever toward the NEUTRAL position.
  - If the engine starts before the forward/reverse lever reaches the NEUTRAL position, the neutral switch must be adjusted. Refer to the Repair Manual.
  - If the engine starts only when the forward/reverse lever is in the NEUTRAL position, the neutral switch is OK.

### 7.16 Testing the Brake System

**Prerequisites** 15° slope

**When** Every 500 hours of service or yearly

**Precaution** Use this test to determine if the parking brake is functioning on the specified slope. This test is not intended to measure the maximum brake holding effort.

**Procedure** Perform the procedure below to test the braking system.

1. Position the machine on a 15° slope as shown.
2. With the engine running, place the throttle control into the LOW IDLE position and the forward/reverse control lever in the NEUTRAL position.
3. Apply the parking brake. The machine should not move.

If the machine moves, maintenance work may be performed only by qualified technicians and authorized service centers.

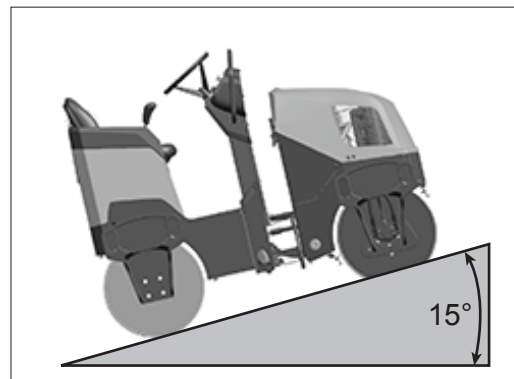

wc\_gr015027

## 7.17 Cleaning the Spray Bars

**Background** Clogged or dirty spray bars can prevent water from spraying onto the drums. If water spray is noticeably reduced or absent even though there is water in the tank, clean the spray bars.

**Requirement**

- Turn off the engine.
- Remove the ignition key.
- Apply the parking brake.

**Procedure** To clean the spray bars:

1. Remove the caps (a) at the ends of each spray bar (b).

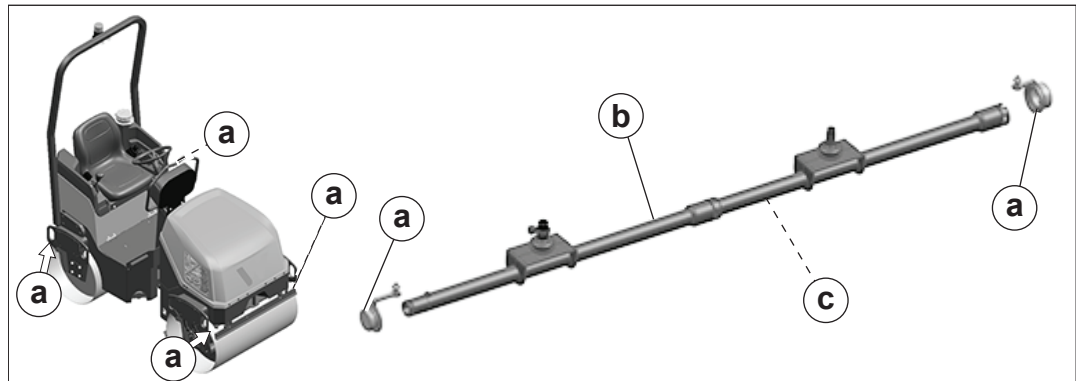

wc\_gr015026

2. Flush the inside of the spray bar with clean water.
3. Install one of the caps, and again flush the inside of the spray bar with clean water. Check for free flow of water through each spray hole (c).
4. If any of the spray holes are blocked, use a brush to clean along the channels at the spray hole. If the spray hole is still blocked, use a small pointed object (for example, a stiff piece of wire) to remove the blockage.
5. Install the second cap when all spray holes are clean.

## 7.18 Long-Term Storage

Extended storage of equipment requires preventive maintenance. Performing these steps helps to preserve machine components and ensures the machine will be ready for future use. While not all of these steps necessarily apply to this machine, the basic procedures remain the same.

---

**When** Prepare your machine for extended storage if it will not be operated for 30 days or more.

---

**Preparing for storage** Perform the procedures below to prepare your machine for storage.

- Complete any needed repairs.
- Replenish or change oils (engine, exciter, hydraulic, and gearcase) per the intervals specified in the Scheduled Maintenance table.
- Grease all fittings and, if applicable, repack bearings.
- Inspect engine coolant. Replace coolant if it appears cloudy, is more than two seasons old, or does not meet the average lowest temperature for your area.
- If your machine has an engine equipped with a fuel valve, start the engine, close the fuel valve, and run the engine until it stops.
- Consult the engine owner's manual for instructions on preparing the engine for storage.

---

**Stabilizing the fuel** After completing the procedures listed above, fill the fuel tank completely and add a high-quality stabilizer to the fuel.

- Choose a stabilizer that includes cleaning agents and additives designed to coat/protect the cylinder walls.
- Make sure the stabilizer you use is compatible with the fuel in your area, fuel type, grade, and temperature range. Do not add extra alcohol to fuels which already contain it (for example, E10).
- For engines with diesel fuel, use a stabilizer with a biocide to restrict or prevent bacteria and fungus growth.
- Add the correct amount of stabilizer per the manufacturer's recommendations.

---

**Storing the machine** Perform these remaining steps to store your machine.

- Wash the machine and allow it to dry.
- Move the machine to a clean, dry, secure storage location. Block or chock the wheels to prevent machine movement.
- Use touch-up paint as needed to protect exposed metal against rust.
- If the machine has a battery, either remove or disconnect it.

**NOTICE:** Allowing the battery to freeze or completely discharge is likely to cause permanent damage. Periodically charge the battery while the machine is not in use. In cold climates, store and charge the battery indoors or in a warm location.

- Cover the machine. Exposed rubber items should be protected from the weather. Either cover them or use a protectant.

## 7.19 Machine Disposal and Decommissioning

**Introduction** This machine must be properly decommissioned at the end of its service life. Responsible disposal of recyclable components, such as plastic and metal, ensures that these materials can be reused—conserving landfill space and valuable natural resources.

Responsible disposal also prevents toxic chemicals and materials from harming the environment. The operating fluids in this machine, including fuel, engine oil, and grease, may be considered hazardous waste in many areas. Before decommissioning this machine, read and follow local safety and environmental regulations pertaining to the disposal of construction equipment.

---

**Preparation** Perform the following tasks to prepare the machine for disposal.

- Move the machine to a protected location where it will not pose any safety hazards and cannot be accessed by unauthorized individuals.
- Ensure that the machine cannot be operated from the time of final shutdown to disposal.
- Drain all fluids, including fuel, engine oil, and coolant.
- Seal any fluid leaks.

---

**Disposal** Perform the following tasks to dispose of the machine.

- Disassemble the machine and separate all parts by material type.
- Dispose of recyclable parts as specified by local regulations.
- Dispose of all non-hazardous components that cannot be recycled.
- Dispose of waste fuel, oil, and grease in accordance with local environmental protection regulations.

# Engine Maintenance—Honda GX630 (Gasoline)

## 8 Engine Maintenance—Honda GX630 (Gasoline)

The viscosity of the engine oil is an important factor when determining the correct engine oil to use in your machine. Use an engine oil of appropriate viscosity based on the expected outside air temperature. See the table below.



### WARNING

Most used liquids from this machine such as oil, gasoline, grease, etc., contain small amounts of materials that can cause cancer and other health problems if inhaled, ingested, or left in contact with skin for prolonged periods of time.

- ▶ Take steps to avoid inhaling or ingesting used liquids.
- ▶ Wash skin thoroughly after exposure to used liquids.

### Recommended Oil

Use 4-stroke motor oil that meets or exceeds the requirements for API service category SJ or later (or equivalent). Always check the API service label on the oil container to be sure it includes the letters SJ or later (or equivalent).

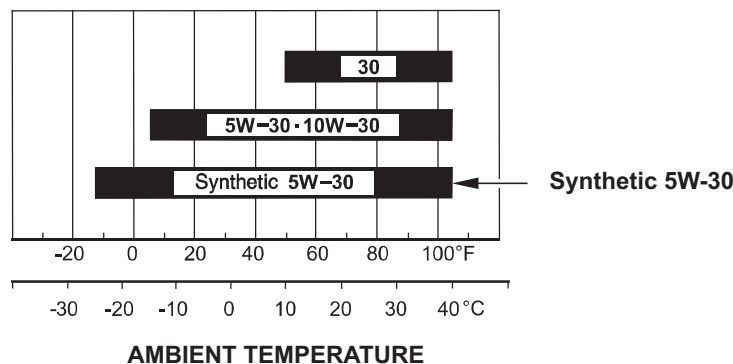

SAE 10W-30 or 5W-30 is recommended for general use. Use a full synthetic 5W-30 for starting/operating temperatures between 5°F (—15°C) and —13°F (—25°C). Other viscosities shown in the chart may be used when the average temperature in your area is within the indicated range.

770044

# Engine Maintenance—Honda GX630 (Gasoline)

The engine maintenance schedule(s) in this chapter are reproduced from the engine owner's manual. For additional information, see the engine owner's manual.

## MAINTENANCE SCHEDULE

REGULAR SERVICE PERIOD (3) Perform at every indicated month or operating hour interval, whichever comes first.		Each use	First month or 10 hrs	Every 6 months or 50 hrs	Every year or 100 hrs	Every 2 years or 300 hrs	Refer to Page
ITEM							
Engine oil	Check level	○					8
	Change		○	○			8
Engine oil filter	Replace		Every 200 Hrs.				9
Air cleaner	Check	○					9
	Clean			○ (1)			9
	Replace					○ *	
Spark plug	Check-adjust			○			10
	Replace				○		
Spark arrester (Applicable types)	Clean			○ (4)			11
Idle speed	Check-adjust				○ (2)		* *
Valve clearance	Check-adjust				○ (2)		* *
Combustion chamber	Clean		After every 1000 Hrs. (2)				* *
Fuel filter	Replace				○ (2)		* *
Fuel tube	Check		Every 2 years (Replace if necessary) (2)				* *

\* Replace the paper filter element only.

\* Refer to the Shop Manual.

(1) Service more frequently when used in dusty areas.

(2) These items should be serviced by your Honda servicing dealer, unless you have the proper tools and are mechanically proficient. Refer to Honda shop manual for service procedures.

(3) For commercial use, log hours of operation to determine proper maintenance intervals.

Failure to follow this maintenance schedule could result in non-warrantable failures.

770045

# Engine Maintenance—Kubota D902 (Diesel)

## 9 Engine Maintenance—Kubota D902 (Diesel)

The viscosity of the engine oil is an important factor when determining the correct engine oil to use in your machine. Use an engine oil of appropriate viscosity based on the expected outside air temperature. See the table below.



### WARNING

Most used liquids from this machine such as oil, gasoline, grease, etc., contain small amounts of materials that can cause cancer and other health problems if inhaled, ingested, or left in contact with skin for prolonged periods of time.

- ▶ Take steps to avoid inhaling or ingesting used liquids.
- ▶ Wash skin thoroughly after exposure to used liquids.

### Oil Viscosity

#### IMPORTANT :

- Engine oil should be MIL-L-2104C or have properties of API classification CF or higher.  
Change the type of engine oil according to the ambient temperature.

Above 25°C (77°F)	SAE30 or SAE10W-30 SAE15W-40
-10°C to 25°C (14°F to 77°F)	SAE10W-30 or SAE15W-40
Below -10°C (14°F)	SAE10W-30

- When using oil different from the previous one, be sure to drain all the previous oil before adding the new engine oil.

770059



# Engine Maintenance—Kubota D902 (Diesel)

The engine maintenance schedule(s) in this chapter are reproduced from the engine owner's manual. For additional information, see the engine owner's manual.

## MAINTENANCE

### SERVICE INTERVALS

Observe the following for service and maintenance.

Interval	Item	Ref. page		
Every 50 hours	Check of fuel pipes and clamp bands	13		@
See NOTE	Change of engine oil (depending on the oil pan)	14,15	⊙	
Every 100 hours	Cleaning of air cleaner element	19	*1	@
	Cleaning of fuel filter	14		
	Check of fan belt tightness	20		
	Draining water separator	-		
Every 200 hours	Replacement of oil filter cartridge (depending on the oil pan)	16	⊙	
	Check of intake air line	-		@
Every 200 hours of operation or six months	Check of radiator hoses and clamp bands	18		
Every 400 hours	Replacement of fuel filter element	14		@
	Cleaning of water separator in fuel tank	-		
Every 500 hours	Cleaning of water jacket (radiator interior)	-		
	Replacement of fan belt	20		
Every year or every 6 cleanings of air cleaner element	Replacement of air cleaner element	19	*2	@
Every 800 hours	Check of valve clearance	-	*3	
Every 1500 hours	Check of fuel injection nozzle injection pressure	-	*3	@
Every 3000 hours	Check of injection pump	-	*3	@
Every two years	Replacement of radiator hoses and clamp bands	18		
	Replacement of fuel pipes and clamps	13	*3	@
	Change of radiator coolant (L.L.C.)	16		
	Replacement of intake air line	-	*4	@

#### IMPORTANT :

- The jobs indicated by ⊙ must be done after the first 50 hours of operation.
- \*1 Air cleaner should be cleaned more often in dusty conditions than in normal conditions.
- \*2 After 6 times of cleaning.
- \*3 Consult your local KUBOTA Dealer for this service.
- \*4 Replace only if necessary.
- The items listed above (@ marked) are registered as emission related critical parts by KUBOTA in the U.S. EPA nonroad emission regulation. As the engine owner, you are responsible for the performance of the required maintenance on the engine according to the above instruction. Please see the Warranty Statement in detail.

770060

# Engine Maintenance—Kubota D902 (Diesel)

**NOTE :**

- Changing interval of Engine oil and oil filter cartridge.

		*Oil pan depth	
		*101 mm (3.98 in.)	121 mm (4.76 in.)
Z602-E4 D902-E4	Engine oil	50 Hrs (Initial)	-
		100 Hrs	
	Oil filter cartridge	200 Hrs	
Z482-E4 D722-E4	Engine oil	50 Hrs (Initial)	
		75 Hrs	100 Hrs
	Oil filter cartridge	150 Hrs	200 Hrs
D782-E4	Engine oil	-	50 Hrs (Initial)
			100 Hrs
	Oil filter cartridge		200 Hrs

\* 101 mm (3.98 in.) oil pan depth is optional for Z482-E4 and D722-E4.

\*\*Standard replacement interval

- American Petroleum Institute (API) classification: above CF-4 grade
- Ambient temperature: below 35°C (95°F)

770061

**NOTICE:** Synthetic oil can be used with Kubota powered machines. When using synthetic oil, the oil change interval is 500 hours.

## 10 Troubleshooting

Problem / Symptom	Reason	Remedy
Engine does not start	Fuel tank is empty	Refill fuel tank.
	Wrong type of fuel	Drain tank, change fuel filter, and refill with the proper fuel.
	Old fuel	Drain tank, change fuel filter, and refill with fresh fuel.
	Fuel system not primed	Prime the fuel system.
	Fuel filter is restricted or clogged	Replace fuel filter.
	Battery connections are loose or corroded, or battery is dead	Check battery connections or replace/charge battery as needed.
	Plugged air cleaner or filter elements	Clean air cleaner or replace filter elements.
	Defective starter motor	Repair or replace.
	Inoperative fuel solenoids on engine	Repair or replace.
	Inoperative starter relay	Repair or replace.
	Loose or broken electrical connections	Check connections and tighten or repair as needed.
Engine stops by itself	Fuel tank is empty	Refill fuel tank.
	Fuel or air filter is restricted or clogged	Clean or replace.
	Loose or broken fuel lines	Check connections and tighten or repair as needed.
No vibration	Defective vibration switch or poor connection	Check components and tighten or repair as needed.
	Damaged or disconnected solenoid on vibration valve	Reconnect or repair solenoid.
	Damaged exciter assembly	Repair the assembly.
	Damaged or broken exciter motor coupling	Repair or replace.
	Damaged exciter motor	Repair or replace.
	Damaged exciter pump	Repair or replace.
	Damaged exciter bearings	Repair or replace.
No travel, or travel only in one direction	Parking brake is engaged	Release parking brake.
	Sheared pin on forward/reverse control	Replace pin.
	Loose or broken control cable	Tighten or replace.
	Damaged drive motor	Repair or replace.
	Damaged drive pump	Repair or replace.
	Defective relief valve(s)	Repair or replace.

Problem / Symptom	Reason	Remedy
No steering	Damaged steering cylinder	Repair or replace.
	Damaged steering valve	Repair or replace.
	Stuck or damaged steering relief valve	Repair or replace.
	Articulated steering joint arm is in the LOCKED position.	Set the articulated steering joint arm to the UNLOCKED position.
Water leaking from spray nozzles when machine is shut off	Check valve damaged or contaminated	Repair or replace check valve.
Low engine oil pressure indicator illuminate	Engine oil level is too low	Fill engine oil to appropriate level.
	Incorrect engine oil viscosity for the time of year	Use correct engine oil viscosity for the seasonal temperature.
	Fault in the engine oil circuit	Repair or replace.

## 11 Technical Data—RD12A (Gasoline)

## 11.1 Engine

Machine		RD12A
<b>Engine</b>		
Engine type		4-stroke, 2 cylinder, air cooled
Engine make		Honda
Engine model		GX 630
Max. rated power @ rated speed <sup>1</sup>	kW (hp)	15.5 (20.8) @ 3,600 rpm
Displacement	cm <sup>3</sup> (in <sup>3</sup> )	688 (42)
Spark plug		(NGK) ZFR5F
Electrode gap	mm (in.)	0.7-0.8 (0.028-0.031)
Engine speed - operating	rpm	3,100
Valve clearance (cold)		
intake:	mm (in.)	0.06-0.10 (0.002-0.004)
exhaust:	mm (in.)	0.08-0.12 (0.003-0.005)
Battery		U1 12VDC 30AH 350A
Air cleaner	type	Dry pleated paper element
Fuel	type	Regular unleaded gasoline
Fuel tank capacity	L (gal)	23.8 (6.3)
Fuel consumption	L (gal)/hr	Up to 6.0 (1.59)
Engine oil	type L (qt)	10W30 SJ or higher 1.9 (2.0)

<sup>1</sup>Net power rating per SAE J1349. Actual power output may vary due to conditions of specific use.

11.2 Roller

Machine		RD12A	
		Fixed ROPS	Folding ROPS
Dry weight	kg (lb)	993 (2,190)	1007 (2,221)
Curb clearance: right left	mm (in.)	400 (15.7) 400 (15.7)	
Water tank capacity	l (gal)	131 (35)	
Outside turning radius	m (ft)	2.85 (9.35)	
Forward/reverse speed	km/hr (mph)	0–8 (0–5)	
Gradeability		30%	
Vibration frequency	vpm	4,200	

11.3 Lubrication

Machine		RD12A
<b>Lubrication</b>		
Hydraulic system	type  L (gal)	Premium grade, anti-wear hydraulic fluid 10W30 1.9 (2.0)
Exciter	type	Mobil SHC 220 grease
Rear drum drive bearing	type qty	Mobil SHC 220 grease as required
Front drum drive bearing	type	Sealed bearings—no lubrication required
Articulated steering joint	type qty	Mobil SHC 220 grease as required

## 11.4 Hydraulic Pressures

System	Operating Pressure		Relief Pressure	
	bar	psi	bar	psi
Drive	55–83	800–1,200	200	2,900
Steering* —while turning	0–80	0–1,160	75–80	1,090–1,160
Vibration —single drum	76–97	1,100–1,400	206	3,000

\* Values for hard-packed surface shown. Values may differ depending on surface.

## 11.5 Sound Measurements

The sound pressure level at operator's location ( $L_{pA}$ ):

- RD12 = 89.5 dB(A)

This sound value was determined according to ISO 3744 for the sound power level ( $L_{WA}$ ).

## 11.6 Measurements of Operator Exposure to Vibration

The operator of this machine should expect to be exposed to vibration levels listed below when using the machine in performance of its normally intended function:

Maximum hand/arm vibration levels are:

- 1.5 m/s<sup>2</sup> (4.9 ft/s<sup>2</sup>)

These are the representative values of the weighted root mean square (**rms**) acceleration to which the hands and arms are subjected. These weighted **rms** values are measured according to ISO 5349-1.

Whole body vibration levels do not exceed:

- 0.22 m/s<sup>2</sup> (0.7 ft/s<sup>2</sup>)

These are the representative values of the weighted root mean square (**rms**) acceleration to which the whole body is subjected. These weighted **rms** values are measured according to ISO 2631-1.

The results are compliant to the limit and action vibration values (hand/arm and whole body) as specified in European directive 2002/44/EC.

11.7 Dimensions

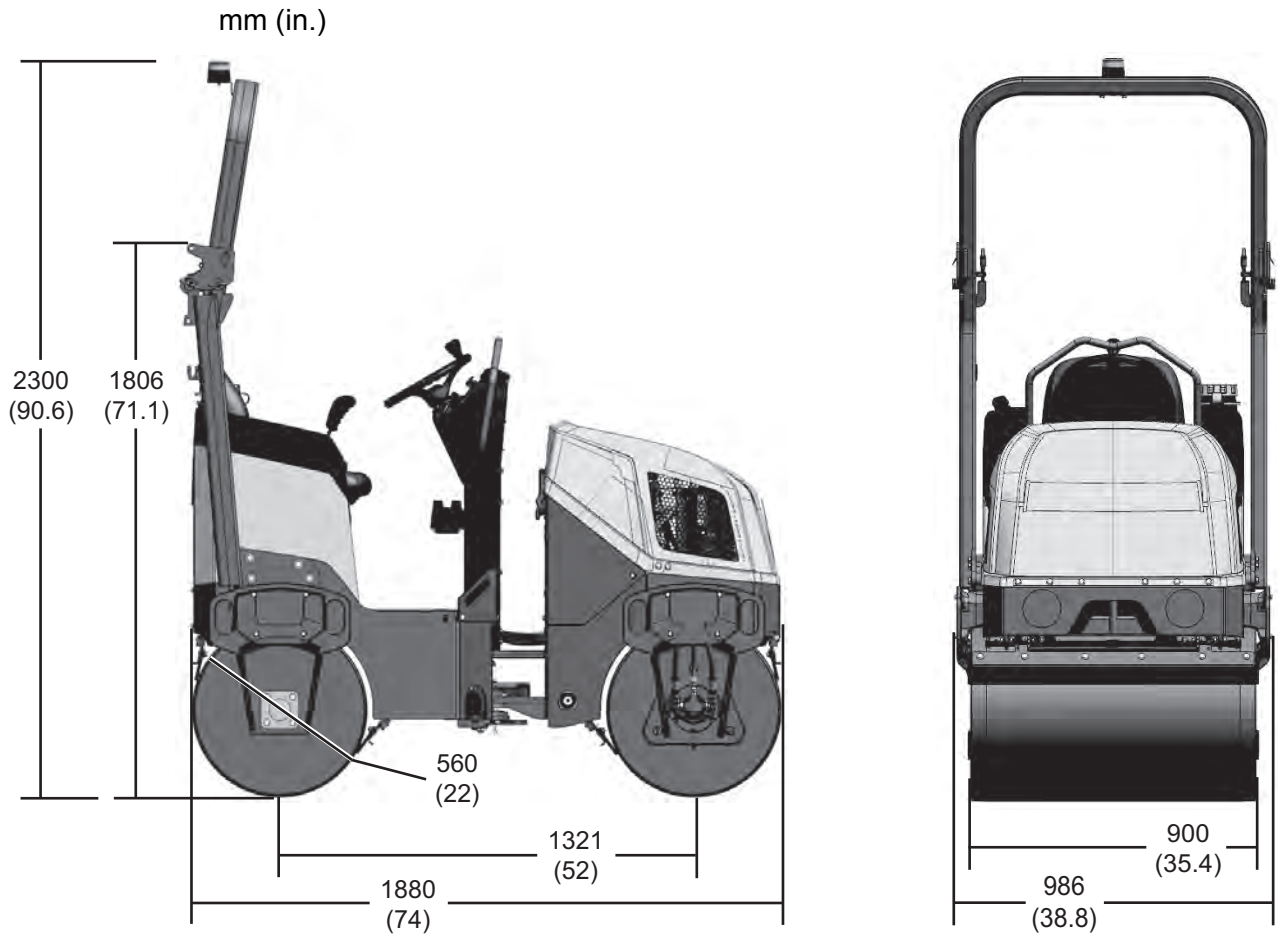

wc\_gr015171



## 12 Technical Data—RD12K (Diesel)

## 12.1 Engine

Machine		RD12K
<b>Engine</b>		
Engine type		4-stroke, 3-cylinder, liquid-cooled
Engine make		Kubota
Engine model		D902
Max. rated power @ rated speed <sup>1</sup>	kW (hp)	16.1 (21.6) @ 3,600 rpm
Displacement	cm <sup>3</sup> (in <sup>3</sup> )	898 (54.8)
Spark plug		(NGK) ZFR5F
Electrode gap	mm (in.)	0.7-0.8 (0.028-0.031)
Engine speed - operating	rpm	3,200
Valve clearance (cold)		
intake:	mm (in.)	0.06-0.10 (0.002-0.004)
exhaust:	mm (in.)	0.08-0.12 (0.003-0.005)
Battery		U1 12VDC 30AH 550A
Air cleaner	type	Dry pleated paper element
Fuel	type	low or ultra-low sulfur diesel
Fuel tank capacity	L (gal)	28.4 (7.5)
Fuel consumption	L (gal)/hr	Up to 5.0 (1.32)
Engine oil	type L (qt)	10W30 CF or higher 3.7 (3.9)

<sup>1</sup>Net power rating per SAE J1349. Actual power output may vary due to conditions of specific use.

12.2 Roller

Machine		RD12K	
		Fixed ROPS	Folding ROPS
Dry weight	kg (lb)	1,045 (2,304)	1,059 (2,335)
Curb clearance: right left	mm (in.)	400 (15.7) 400 (15.7)	
Water tank capacity	l (gal)	131 (35)	
Outside turning radius	m (ft)	2.94 (9.65)	
Forward/reverse speed	km/hr (mph)	0–8 (0–5)	
Gradeability		30%	
Vibration frequency	vpm	4,200	

12.3 Lubrication

Machine		RD12K
<b>Lubrication</b>		
Hydraulic system	type  L (gal)	Premium grade, anti-wear hydraulic fluid 10W30 1.9 (0.5)
Exciter	type	Mobil SHC 220 grease
Rear drum drive bearing	type qty	Mobil SHC 220 grease as required
Front drum drive bearing	type	Sealed bearings—no lubrication required
Articulated steering joint	type qty	Mobil SHC 220 grease as required

## 12.4 Hydraulic Pressures

System	Operating Pressure		Relief Pressure	
	bar	psi	bar	psi
Drive	55–83	800–1,200	200	2,900
Steering* —while turning	0–80	0–1,160	75–80	1,090–1,160
Vibration —single drum	76–97	1,100–1,400	206	3,000

\* Values for hard-packed surface shown. Values may differ depending on surface.

## 12.5 Sound Measurements

The sound pressure level at operator's location ( $L_{pA}$ ):

- RD12 = 91.3 dB(A)

This sound value was determined according to ISO 3744 for the sound power level ( $L_{WA}$ ).

## 12.6 Measurements of Operator Exposure to Vibration

The operator of this machine should expect to be exposed to vibration levels listed below when using the machine in performance of its normally intended function:

Maximum hand/arm vibration levels are:

- $3.2 \text{ m/s}^2$  ( $10.5 \text{ ft/s}^2$ )

These are the representative values of the weighted root mean square (**rms**) acceleration to which the hands and arms are subjected. These weighted **rms** values are measured according to ISO 5349-1.

Whole body vibration levels do not exceed:

- $0.22 \text{ m/s}^2$  ( $0.7 \text{ ft/s}^2$ )

These are the representative values of the weighted root mean square (**rms**) acceleration to which the whole body is subjected. These weighted **rms** values are measured according to ISO 2631-1.

The results are compliant to the limit and action vibration values (hand/arm and whole body) as specified in European directive 2002/44/EC.

12.7 Dimensions

mm (in.)

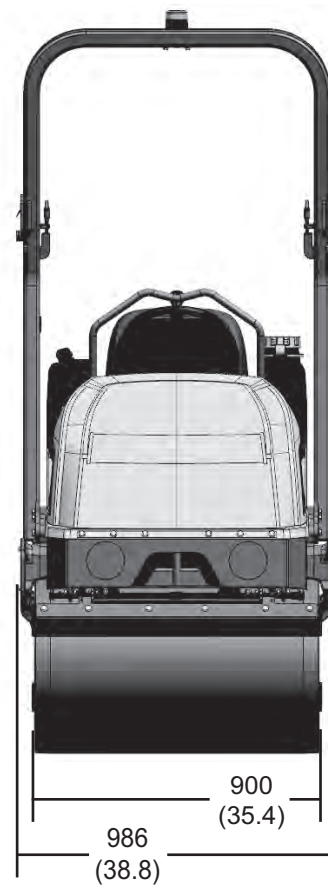
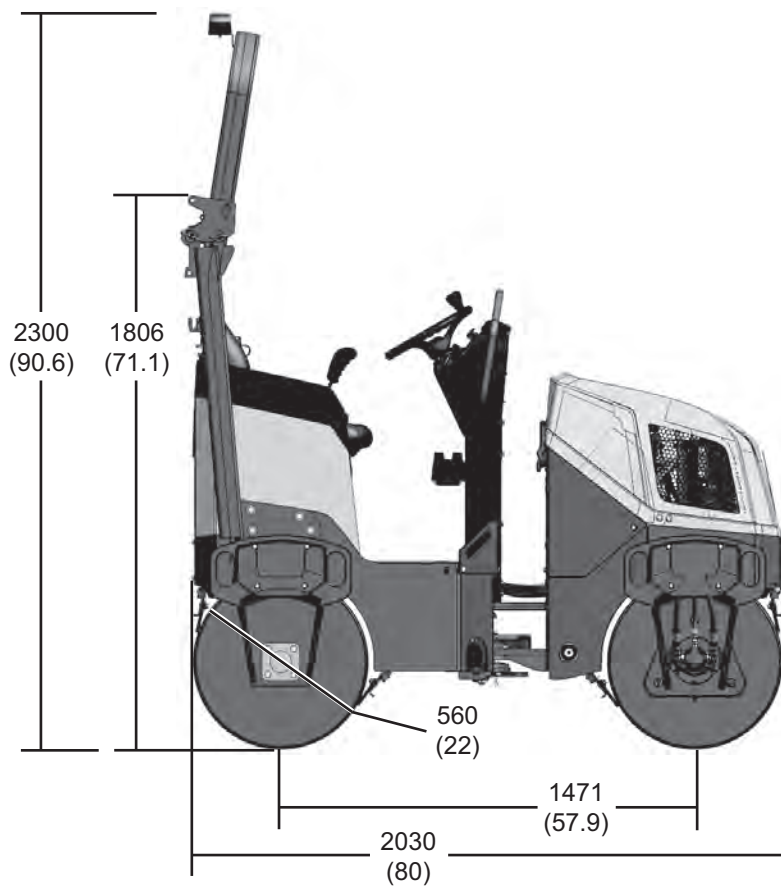

wc\_gr015185

## 13 Emission Control Systems Information and Warranty—Gasoline

The Emission Control Warranty and associated information is valid only for the U.S.A., its territories, and Canada.

### 13.1 Emission Control System Background Information

#### Introduction

Wacker Neuson spark-ignited engines/equipment must conform with applicable Environmental Protection Agency (EPA) and the State of California emissions regulations. There are two types of emissions that fall under these regulations: 1) exhaust, and 2) evaporative. These regulations require that manufacturers warrant the emission control systems for defects in materials and workmanship.

Furthermore, EPA and California regulations require all manufacturers to furnish written instructions describing how to operate and maintain the engines/equipment including the emission control systems. This information is provided with all Wacker Neuson engines/equipment at the time of purchase.

---

#### Exhaust Emissions

The combustion process produces carbon monoxide, oxides of nitrogen, and hydrocarbons. Control of hydrocarbons and oxides of nitrogen is very important because, under certain conditions, they react to form photochemical smog when subjected to sunlight. Carbon monoxide does not react in the same way, but it is toxic.

Wacker Neuson utilizes lean carburetor settings and other systems to reduce the emissions of carbon monoxide, oxides of nitrogen, and hydrocarbons.

---

#### Evaporative Emissions

Evaporative emissions are fuel emissions and generally include emissions that result from permeation of fuel through the fuel-system materials or from ventilation of the fuel system.

Wacker Neuson utilizes low-permeation fuel lines and fuel tanks where applicable to reduce evaporative emissions.

---

#### Problems that may affect Emissions

If any of the following symptoms arise, have the engine/equipment inspected and repaired by a Wacker Neuson dealer/service center.

- Hard starting or stalling after starting
- Rough idling
- Misfiring or backfiring under load
- Afterburning (backfiring)
- Presence of black exhaust smoke during operation
- High fuel consumption

# Emission Control Systems Information and Warranty—Gasoline

## Tampering and Altering

Tampering with or altering the emission control system may increase emissions beyond the legal limit. If evidence of tampering is found, Wacker Neuson may deny a warranty claim. Among those acts that constitute tampering are:

- Removing or altering of any part of the air intake, fuel, or exhaust systems.
- Altering or defeating the speed-adjusting mechanism causing the engine to operate outside its design parameters.

## 13.2 Limited Defect Warranty for Exhaust Emission Control System

See the supplied engine owner's manual for the applicable emission warranty statement.

## 13.3 Limited Defect Warranty for Wacker Neuson Evaporative Emission Control Systems

The Emission Control Warranty is valid only for the U.S.A., its territories, and Canada.

Wacker Neuson Sales Americas, LLC, N92 W15000 Anthony Avenue, Menomonee Falls, WI 53051, (hereinafter "Wacker Neuson") warrants to the initial retail purchaser and each subsequent owner, that this engine/equipment, including all parts of its evaporative emission control system, have been designed, built, and equipped to conform at the time of initial sale to all applicable evaporative emission regulations of the U.S. Environmental Protection Agency (EPA), and that the engine/equipment is free of defects in materials and workmanship which would cause this engine/equipment to fail to conform to EPA regulations during its warranty period.

Wacker Neuson is also liable for damages to other engine/equipment components caused by a failure of any warranted parts during the warranty period.

---

### Limited Defect Warranty Period for Wacker Neuson Evaporative Emission Control Systems

The warranty period for this engine/equipment begins on the date of sale to the initial purchaser and continues for a minimum of two (2) years. For the warranty terms for your specific engine/equipment, visit [wackerneuson.com](http://wackerneuson.com).

Any implied warranties are limited to the duration of this written warranty.

---

### What is covered

Wacker Neuson recommends the use of genuine Wacker Neuson parts, or the equivalent, whenever maintenance is performed. The use of replacement parts not equivalent to the original parts may impair the effectiveness of the engine/equipment emission controls systems. If such a replacement part is used in the repair or maintenance of the engine/equipment, assure yourself that such part is warranted by its manufacturer to be equivalent to the parts offered by Wacker Neuson in performance and durability. Furthermore, if such a replacement part is

## Emission Control Systems Information and Warranty—Gasoline

used in the repair or maintenance of the engine/equipment, and an authorized Wacker Neuson dealer/service center determines it is defective or causes a failure of a warranted part, the claim for repair of the engine/equipment may be denied. If the part in question is not related to the reason the engine/equipment requires repair, the claim will not be denied.

For the components listed in the following table, an authorized Wacker Neuson dealer/service center will, at no cost to you, make the necessary diagnosis, repair, or replacement necessary to ensure that the engine/equipment complies with the applicable EPA regulations. All defective parts replaced under this warranty become property of Wacker Neuson.

System Covered	Components
Evaporative emissions	Fuel tank (if applicable)
	Fuel tank cap (if applicable)
	Fuel line (if applicable)
	Fuel line fittings (if applicable)
	Clamps (if applicable)
	Carbon canister (if applicable)
	Purge port connector (if applicable)
Miscellaneous parts associated with the evaporative emission control system	Clamps
	Gaskets
	Mounting brackets

### What is not covered

- Failures other than those resulting from defects in material or workmanship.
- Any systems or parts which are affected or damaged by owner abuse, tampering, neglect, improper maintenance, misuse, improper fueling, improper storage, accident and/or collision; the incorporation of, or any use of, add-on or modified parts, or unsuitable attachments, or the alteration of any part.
- Replacement of expendable maintenance items made in connection with required maintenance services after the item's first scheduled replacement as listed in the maintenance section of the engine/equipment operator's manual, such as spark plugs and filters.
- Incidental or consequential damages such as loss of time or the use of the engine/equipment, or any commercial loss due to the failure of the engine/equipment.
- Diagnosis and inspection charges that do not result in warranty-eligible service being performed.
- Any non-authorized replacement part, or malfunction of authorized parts due to use of non-authorized parts.

# Emission Control Systems Information and Warranty—Gasoline

## Owner's Warranty Responsibility

The engine/equipment owner, is responsible for the performance of the required maintenance listed in the Wacker Neuson engine/equipment operator's manual. Wacker Neuson recommends that all receipts covering maintenance on the engine/equipment be retained, but Wacker Neuson cannot deny warranty coverage solely for the lack of receipts or for the failure to ensure the performance of all scheduled maintenance.

Normal maintenance, replacement, or repair of emission control devices and systems may be performed by any repair establishment or individual; however, warranty repairs must be performed by an authorized Wacker Neuson dealer/service center.

The engine/equipment must be presented to an authorized Wacker Neuson dealer/service center as soon as a problem exists. Contact Wacker Neuson Product Support Department (1-800-770-0957) or visit [wackerneuson.com](http://wackerneuson.com) to find a dealer/service center in your area, or to answer questions regarding warranty rights and responsibilities.

---

## How to Make a Claim

In the event that any emission-related part is found to be defective during the warranty period, you shall notify Wacker Neuson Product Support Department (1-800-770-0957, or [technical.support@wackerneuson.com](mailto:technical.support@wackerneuson.com), or [wackerneuson.com](http://wackerneuson.com)), and you will be advised of the appropriate dealer/service center where warranty repair can be performed. All repairs qualifying under this limited warranty must be performed by an authorized Wacker Neuson dealer/service center.

You must take your Wacker Neuson engine/equipment along with proof of original purchase date, at your expense, to the authorized Wacker Neuson dealer/service center during their normal business hours.

For owners located more than 100 miles from an authorized dealer/service center (excluding the states with high-altitude areas as identified in 40 CFR Part 1068, Appendix III), Wacker Neuson will pay for pre-approved shipping costs to and from an authorized Wacker Neuson dealer/service center.

Claims for repair or adjustment found to be caused solely by defects in material or workmanship will not be denied because the engine/equipment was not properly maintained and used.

The warranty repairs should be completed in a reasonable amount of time, not to exceed 30 days.



## 14 Emission Control Systems Information and Warranty—Diesel

The Emission Control Warranty and associated information is valid only for the U.S.A., its territories, and Canada.

### 14.1 Emission Control System Background Information

#### Introduction

Wacker Neuson engines/equipment must conform with applicable Environmental Protection Agency (EPA) and California Air Resource Board (CARB) emissions regulations. These regulations require that manufacturers warrant the emission control systems for defects in materials and workmanship.

Furthermore, EPA and CARB regulations require all manufacturers to furnish written instructions describing how to operate and maintain the engines/equipment including the emission control systems. This information is provided with all Wacker Neuson engines/equipment at the time of purchase.

---

#### Exhaust Emissions

The combustion process produces carbon monoxide, oxides of nitrogen, and hydrocarbons. Control of hydrocarbons and oxides of nitrogen is very important because, under certain conditions, they react to form photochemical smog when subjected to sunlight. Carbon monoxide does not react in the same way, but it is toxic.

---

#### Problems that may affect Emissions

If any of the following symptoms arise, have the engine/equipment inspected and repaired by a Wacker Neuson dealer/service center.

- Hard starting or stalling after starting
  - Rough idling
  - Misfiring or backfiring under load
  - Afterburning (backfiring)
  - Presence of black exhaust smoke during operation
  - High fuel consumption
- 

#### Tampering and Altering

Tampering with or altering the emission control system may increase emissions beyond the legal limit. If evidence of tampering is found, Wacker Neuson may deny a warranty claim. Among those acts that constitute tampering are:

- Removing or altering of any part of the air intake, fuel, or exhaust systems.
- Altering or defeating the speed-adjusting mechanism causing the engine to operate outside its design parameters.

# Emission Control Systems Information and Warranty—Diesel

## 14.2 Limited Defect Warranty for Exhaust Emission Control System

See the supplied engine owner's manual for the applicable emission warranty statement.

## 14.3 Limited Defect Warranty for Wacker Neuson Emission Control Systems

The Emission Control Warranty is valid only for the U.S.A., its territories, and Canada.

Wacker Neuson Sales Americas, LLC, N92 W15000 Anthony Avenue, Menomonee Falls, WI 53051, (hereinafter "Wacker Neuson") warrants to the initial retail purchaser and each subsequent owner, that this engine/equipment, including all parts of its emission control system, have been designed, built, and equipped to conform at the time of initial sale to all applicable evaporative emission regulations of the U.S. Environmental Protection Agency (EPA), and that the engine/equipment is free of defects in materials and workmanship which would cause this engine/equipment to fail to conform to EPA regulations during its warranty period.

Wacker Neuson is also liable for damages to other engine/equipment components caused by a failure of any warranted parts during the warranty period.

---

### What is covered

Wacker Neuson recommends the use of genuine Wacker Neuson parts, or the equivalent, whenever maintenance is performed. The use of replacement parts not equivalent to the original parts may impair the effectiveness of the engine/equipment emission controls systems. If such a replacement part is used in the repair or maintenance of the engine/equipment, assure yourself that such part is warranted by its manufacturer to be equivalent to the parts offered by Wacker Neuson in performance and durability. Furthermore, if such a replacement part is used in the repair or maintenance of the engine/equipment, and an authorized Wacker Neuson dealer/service center determines it is defective or causes a failure of a warranted part, the claim for repair of the engine/equipment may be denied. If the part in question is not related to the reason the engine/equipment requires repair, the claim will not be denied.

For the components listed in the following table, an authorized Wacker Neuson dealer/service center will, at no cost to you, make the necessary diagnosis, repair, or replacement necessary to ensure that the engine/equipment complies with the applicable EPA regulations. All defective parts replaced under this warranty become property of Wacker Neuson.

System Covered	Components
Air filter system and associated plumbing (Before engine intake)	Air filter
	Air filter plumbing
Exhaust system connected after the Exhaust Manifold	Exhaust gas piping and muffler connected to the Exhaust Manifold

# Emission Control Systems Information and Warranty—Diesel

## What is not covered

- Failures other than those resulting from defects in material or workmanship.
  - Any systems or parts which are affected or damaged by owner abuse, tampering, neglect, improper maintenance, misuse, improper fueling, improper storage, accident and/or collision; the incorporation of, or any use of, add-on or modified parts, or unsuitable attachments, or the alteration of any part.
  - Replacement of expendable maintenance items made in connection with required maintenance services after the item's first scheduled replacement as listed in the maintenance section of the engine/equipment operator's manual, such as spark plugs and filters.
  - Incidental or consequential damages such as loss of time or the use of the engine/equipment, or any commercial loss due to the failure of the engine/equipment.
  - Diagnosis and inspection charges that do not result in warranty-eligible service being performed.
  - Any non-authorized replacement part, or malfunction of authorized parts due to use of non-authorized parts.
- 

## Owner's Warranty Responsibility

The engine/equipment owner, is responsible for the performance of the required maintenance listed in the Wacker Neuson engine/equipment operator's manual. Wacker Neuson recommends that all receipts covering maintenance on the engine/equipment be retained, but Wacker Neuson cannot deny warranty coverage solely for the lack of receipts or for the failure to ensure the performance of all scheduled maintenance.

Normal maintenance, replacement, or repair of emission control devices and systems may be performed by any repair establishment or individual; however, warranty repairs must be performed by an authorized Wacker Neuson dealer/service center.

The engine/equipment must be presented to an authorized Wacker Neuson dealer/service center as soon as a problem exists. Contact Wacker Neuson Product Support Department (1-800-770-0957) or visit [wackerneuson.com](http://wackerneuson.com) to find a dealer/service center in your area, or to answer questions regarding warranty rights and responsibilities.

---

## How to Make a Claim

In the event that any emission-related part is found to be defective during the warranty period, you shall notify Wacker Neuson Product Support Department (1-800-770-0957, or [technical.support@wackerneuson.com](mailto:technical.support@wackerneuson.com), or [wackerneuson.com](http://wackerneuson.com)), and you will be advised of the appropriate dealer/service center where warranty repair can be performed. All repairs qualifying under this limited warranty must be performed by an authorized Wacker Neuson dealer/service center.

## Emission Control Systems Information and Warranty—Diesel

You must take your Wacker Neuson engine/equipment along with proof of original purchase date, at your expense, to the authorized Wacker Neuson dealer/service center during their normal business hours.

For owners located more than 100 miles from an authorized dealer/service center (excluding the states with high-altitude areas as identified in 40 CFR Part 1068, Appendix III), Wacker Neuson will pay for pre-approved shipping costs to and from an authorized Wacker Neuson dealer/service center.

Claims for repair or adjustment found to be caused solely by defects in material or workmanship will not be denied because the engine/equipment was not properly maintained and used.

The warranty repairs should be completed in a reasonable amount of time, not to exceed 30 days.



# SAFETY MANUAL

## FOR OPERATING AND MAINTENANCE PERSONNEL

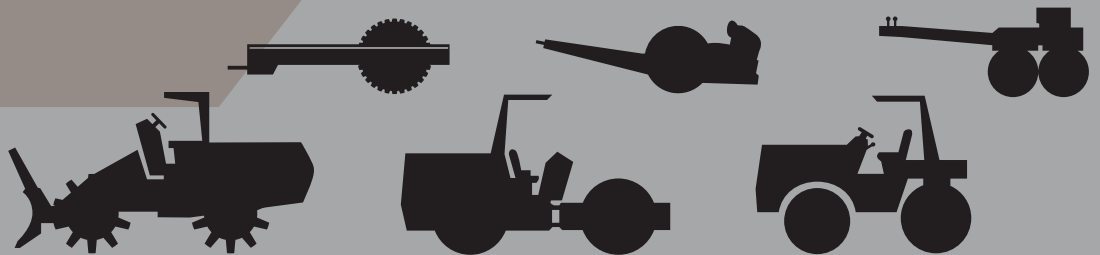

## Table of Contents

Acknowledgment.....	2
Foreword .....	3
Safety Alerts.....	4
A Word to the User/Operator .....	5
Types of Roller Compactors.....	6
Follow a Safety Program.....	7
Prepare for Safe Operation.....	12
Start Safely.....	17
Operate Safely .....	20
Shut Down Safely .....	30
Perform Maintenance Safely .....	31
Final Word to the User .....	43

## Acknowledgment

We wish to thank the members of the Association of Equipment Manufacturers for their invaluable contributions in preparing this Safety Manual.

### NOTICE OF COPYRIGHT PROTECTION

Copyright 2014, by the Association of Equipment Manufacturers. All rights reserved. This work may not be reproduced or disseminated in whole or in part by any means without the prior written permission of the Association of Equipment Manufacturers.

# Foreword

This safety manual is intended to point out some of the basic safety situations that may be encountered during the normal operation and maintenance of your machine and to instruct you in safety practices for dealing with these conditions. This manual is **NOT** a substitute for the manufacturer's operator's manual(s).

Additional precautions may be necessary, or some instructions may not apply, depending on equipment, attachments and conditions at the jobsite or in the service area. The manufacturer has no direct control over equipment application, operation, inspection or maintenance. Therefore, it is **YOUR** responsibility to use good safety practices in these areas.

The information provided in this manual supplements the specific information about your machine that is contained in the manufacturer's operator's manual(s). Other information that may affect the safe operation of your machine may be contained on safety signs or in insurance requirements, employer's safety and training programs, safety codes, local, state/provincial and federal laws, rules and regulations.

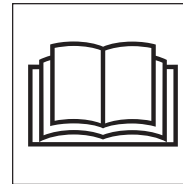

**Read and understand  
manuals before  
operating**

**IMPORTANT!** Before you operate this machine, make sure you have the manufacturer's manual(s) for this machine and all attachments. If the manufacturer's manuals are missing, obtain replacements from your employer, equipment dealer or directly from the manufacturer. Keep this safety manual and the manufacturer's manuals with the machine at all times. Read and understand all manuals.

Safety videos and other training resources are available from some manufacturers and dealers. Operators are encouraged to periodically review these resources.

## Safety Alerts

### Safety Alert Symbol

This Safety Alert Symbol means: "**ATTENTION! STAY ALERT! YOUR SAFETY IS INVOLVED!**"



The Safety Alert Symbol identifies important safety messages on equipment, safety signs, in manuals or elsewhere. When you see this symbol, be alert to the possibility of death or personal injury. Carefully read the message that follows and inform other operators. Follow instructions in the safety message.

### Signal Words

Signal words are distinctive words that will typically be found on safety signs on the roller compactor and other jobsite equipment. These words may also be found in this manual and the manufacturer's manuals. These words are intended to alert the operator to a hazard and the degree of severity of the hazard.



**DANGER** indicates a hazardous situation that, if not avoided, will result in death or serious injury.



**WARNING** indicates a hazardous situation that, if not avoided, could result in death or serious injury.



**CAUTION** indicates a hazardous situation that, if not avoided, could result in minor or moderate injury.



**NOTICE** indicates a property damage message.

# A Word to the User/Operator

It is **YOUR** responsibility to read and understand this safety manual and the manufacturer's manuals before operating this equipment. This safety manual takes you step by step through the working day.

Graphics have been provided to help you understand the text.

Hazard recognition and accident prevention depend upon you being alert, careful and properly trained in the inspection, operation, transport, maintenance and storage of this equipment.



Read and understand all safety signs – replace damaged signs

Remember that **YOU** are the key to safety. Good safety practices not only protect you but also protect the people around you. Study this manual and the manufacturer's manuals for the specific machine. Make them a working part of your safety program. Keep in mind that this safety manual is written only for the types of roller compactors covered.

After studying the manufacturer's manuals and this safety manual, please contact the equipment manufacturer with any remaining questions.

**Practice all usual and customary safe working precautions and remember:**  
**SAFE OPERATION IS UP TO YOU!**  
**YOU CAN PREVENT DEATH OR SERIOUS INJURY CAUSED BY UNSAFE WORK PRACTICES!**

## Types of Roller Compactors

This safety manual covers many different types of roller compactors including: steel wheel rollers, vibratory rollers, rubber-tired rollers, segmented pad/sheepsfoot soil compactors and landfill compactors. These may be either ride-on, walk-behind, or towed rollers. They may be used for the compaction of asphalt, soil, landfill or other materials. Excluded from coverage are vibratory plates and hand rammers.

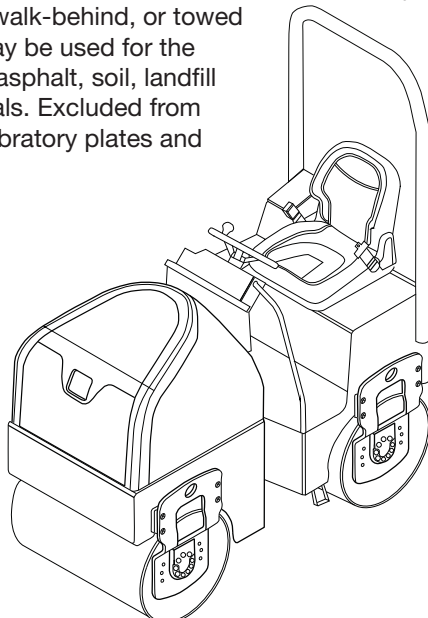

Ride-on

Regardless of which machine you operate, it is your responsibility to study and understand this safety manual, and to see that a copy remains with your machine. Manufacturers produce machines with many built-in safety features. Employers provide accident prevention programs. Yet, the ultimate responsibility to operate and maintain your machine with the skill, care and knowledge essential for safety is yours.

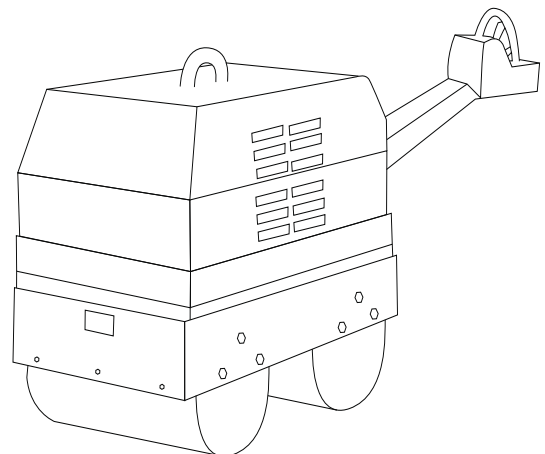

Walk-behind

# Follow a Safety Program

## For Safe Operation

You must be a qualified and authorized operator for safe operation of this machine. You must clearly understand the written instructions supplied by the manufacturer, be trained — including actual operation — and know the safety rules and regulations for the jobsite. It is a good safety practice to point out and explain safety signs and practices to others, and to make sure they understand the importance of following these instructions.



**Never operate while impaired by alcohol or drugs**

**⚠ WARNING!** Drugs and alcohol affect operator alertness and coordination, and the ability to safely operate the equipment. **Never operate the machine while impaired by use of alcohol or drugs. Never knowingly allow anyone to operate the machine when their alertness or coordination is impaired.**

An operator taking prescription or over-the-counter medication must consult a medical professional regarding any side effects of the medication that would hinder their ability to safely operate this equipment.

## Be Alert!

Know where to get assistance. Keep emergency numbers for doctors, ambulance service, hospital and fire department near your telephone. Know how to use a first aid kit and fire extinguisher/fire suppression system; know their location and practice getting to them. Ensure they have been properly tested and maintained.

Let others know where you will be working, and what time you will be returning. In case of an emergency, you want others to know where to find you.

## Be Aware!

Take advantage of training programs offered.

Know the proper response to a fire or chemical spill on your machine.

# Follow a Safety Program

## Be Careful!

Human error is the result of many factors: carelessness, fatigue, sensory overload, preoccupation, unfamiliarity with the machine or attachments, or drugs and alcohol, to name a few. You can avoid death or serious injury caused by these and other unsafe work practices. Be careful; never assume accidents cannot happen to you.

For your safety and the safety of others, act safely and encourage your fellow workers to act safely as well.

## Protect Yourself

Wear all the personal protective clothing and Personal Protective Equipment (PPE) issued to you or called for by job conditions.

You may need:

- Hard hat.
- Safety shoes.
- Safety glasses, goggles or face shield.
- Heavy duty gloves.
- Hearing protection.
- Reflective clothing.
- Wet weather gear.
- Respirator or filter mask.

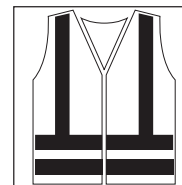
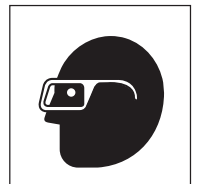

Wear whatever is needed to protect yourself — don't take chances.

**⚠ WARNING!** Avoid death or serious injury from entanglement. **Do not wear loose clothing or accessories that could catch on moving parts or controls.** Examples of items to avoid include flopping cuffs, dangling neckties and scarves, wallets attached to chains, jewelry and wrist watches.



# Follow a Safety Program

## Know the Rules

Most job sites have rules governing equipment use and maintenance. Before you start work at a new location, check with the supervisor or safety coordinator. Ask about the rules you will be expected to obey.

OSHA enforces federal laws within the United States that apply to the safe operation, application and maintenance of equipment on some jobsites. It is the employer's responsibility to comply with these laws. A federal representative may periodically inspect a jobsite to see that these laws are being followed.

There may be other local, state/provincial, federal laws or international organizations that regulate the use of this equipment, along with specific jobsite or employer rules. It is important that you know and comply with all applicable laws and rules, **including those requiring operator training and certification.**

### These are some of the rules you must work by:

- Only qualified and authorized individuals may operate this equipment.
- Inspect your machine and attachments before each use as specified by the manufacturer and your employer.

- Know the capacity and operating characteristics of your equipment. Do not misuse it.
- Wear proper clothing and PPE. Check that others are also wearing appropriate clothing.
- All shields, guards, air filters, access panels and doors must be properly installed before each use.
- Know the rules regarding traffic at your jobsite. Know what all signs, flags, and markings mean. Know hand, flag, horn, whistle, siren, or bell signals, if used.
- Never modify or remove any part of the machine (except for service; then make sure the part is re-installed or replaced if defective or worn out).



**Know and understand rules of operation**



**Understand jobsite signals**

# Follow a Safety Program

- **Never allow children to play near, ride on, or operate the equipment.**
- Keep bystanders well clear of the operation.
- Know the work area before you use the equipment. Be aware of possible hazards, including those overhead and underground.
- Only use attachments and parts that are approved by the manufacturer.
- Do not allow riders.
- Fasten seat belt or operator restraint before starting.
- Drive forward whenever possible.
- Always look in the direction of travel.
- Check correct mirror settings, if available.
- Look before backing up.
- Never leave the operator's seat without stopping the engine and removing the ignition key, if equipped. (See page 30, **Safe Shutdown.**)
- Use three-point contact (handholds and steps) and face the equipment when mounting or dismounting. (See page 17, **Mount and Dismount Properly.**)



**Fasten seat belt or operator restraint**

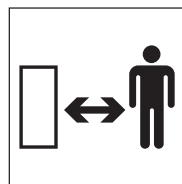

**Keep bystanders away**

# Follow a Safety Program

## Know the Equipment

Read and understand the DANGER, WARNING, CAUTION and NOTICE safety labels and other informational signs on the machine and the attachments, and in the manufacturer's operating manuals. Ask your supervisor or dealer to explain any information you do not understand. Failure to obey safety instructions could result in death or serious injury.

### Know the following about your equipment:

- Function, purpose and use of all controls.
- Correct operation speeds.
- Slope and uneven terrain capabilities and proper operation under all conditions.
- Braking and steering characteristics.
- Turning radius and clearances.
- How to quickly stop equipment in an emergency.
- Rated operating capacity.

Keep in mind that rain, snow, ice, loose gravel, soft ground, slopes, and other site conditions can affect your machine's operating capabilities. Make sure you are thoroughly familiar with your machine's stability, braking, traction, and other handling characteristics under any conditions you are likely to encounter.

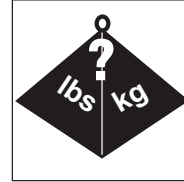

**Know machine capacity and operating characteristics**

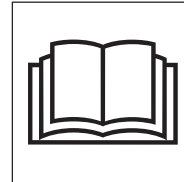

**Read and understand manuals before operating**

11

## Prepare for Safe Operation

### Check and Use All Available Safety Devices

To protect you and others around you, your machine may be equipped with the safety equipment listed below. Additional equipment may be required or some items may not apply, depending on attachments used, jobsite conditions or applicable jobsite rules. Check that each required item is securely in place and in operating condition:

- Falling Object Protective Structure (FOPS).
- Rollover Protective Structure (ROPS).
- Safety Guards.
- Seat Belt.
- Operator seat/restraint bar(s)/interlock control system.
- Cab side-screens or windows.
- Special enclosures or accessories required for specific applications or jobsite conditions.
- Alternate exit (window).
- Grab handles.
- Guard Rails.
- Articulated joint locks
- Lights.
- Mirrors.

- Anti-skid tread/steps.
- Safety signs.
- Horn.
- Guards.
- Back-up alarm.
- Emergency stop control.
- Fire extinguisher.
- First aid kit.
- Rotating beacon.
- Windshield wiper/defroster.

Use them! Never remove or disconnect any safety device. Replace any damaged, missing, or non-functional safety devices before resuming machine operation.

**⚠ WARNING! Never remove or modify a ROPS or FOPS.** Serious injury or death could result.



**Fasten your seat belt**

# Prepare for Safe Operation

## Check the Machine

Before beginning your work day, inspect the machine and have all systems in good operational condition.

- Perform daily and periodic service procedures as instructed by the equipment manufacturer.
- Check for broken, missing, loose, or damaged parts. Make necessary repairs.
- Check that all drum mounting bushes are pliable and free from damage.
- Check the water sprinkler system. Open the valve and make sure water flows through every hole in each spray bar.
- Check the tires for cuts, missing lugs, bulges, and correct pressure.
- Keep the steps and handholds clean and free of grease, oil, dirt, snow or ice.
- Check the parking brake for proper operation.
- Check condition and operation of any attachments.
- Ensure shielding is properly installed and in good condition. Repair or replace if damaged or missing.
- Ensure work lights (if equipped) are kept clean. Check that all lights work properly.
- Ensure the horn and back-up alarm (if equipped) are operating correctly. Repair or replace if damaged.

- Ensure any Slow Moving Vehicle (SMV) signs, reflectors and warning lights are in good condition and can be clearly seen. Repair or replace if damaged.
- Ensure all tools or loose objects are removed or securely fastened while operating the machine.
- Check for damaged or leaky hydraulic systems. Repair or adjust as needed.



**Inspect  
the machine before  
each work shift**

## Hydraulic Fluid Injection Hazard

**⚠ WARNING!** Accidental injection of high-pressure oil into the hands or body is dangerous and could result in death or serious injury. **Use caution when checking hydraulic leaks as pressurized hydraulic fluid has enough force to penetrate skin, causing serious personal injury.**

13

# Prepare for Safe Operation

If a leak is discovered:

- Ensure engine is turned off; relieve pressure in hydraulic circuit.
- Wear proper hand and eye protection.
- Visually examine the hydraulic hose or fluid lines in the vicinity of the leak for breaks or cracks. **Do not** use your hand to check for leaks.
- Repair or replace hydraulic lines per manufacturer's recommendation.

Fluid injection injuries are not always obvious. Victims have reported such injuries feel like a bee sting or splinter under the skin. If you suspect you have a fluid injection injury, do not take chances. Seek proper medical care immediately. If any fluid is injected into the skin, it must be surgically removed within a few hours by a doctor familiar with this type of injury.

## Check the Cooling System

When checking the cooling system, make sure the engine is turned off and is cool. Remove the key to prevent fans from unexpectedly starting. Ensure the coolers and engine compartment are clean and free from debris, which could ignite and cause a fire.

If the machine is air-cooled, be sure the cooling unit has an unobstructed air flow. If it is liquid-cooled, check coolant level (at overflow tank, if provided).

**⚠ WARNING!** Allow the radiator to cool before checking the level. Hot radiator fluids could escape as steam and burn you. (See page 36, **Engine Coolant Hazards.**)

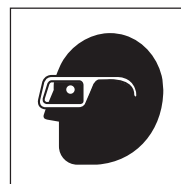

**Wear  
eye protection**



**High pressure  
fluid can inject  
into the body**

# Prepare for Safe Operation

## Clean Up

Clean windows, lights, mirrors, and safety signs.

Make sure the operator's area, steering levers, pedals, joysticks, steps, and grab handles are clean. Oil, grease, snow, ice, mud, or debris in these areas could cause you to slip and fall, or lose control of the machine. Clean your boots of excess mud before entering the machine.

Remove all personal items or other objects from the operator's area. Secure these items in a toolbox or remove them from the machine.

## Use Caution When Fueling

**⚠ WARNING!** Avoid injury from fire or explosion. **Never fill the fuel tank in poorly ventilated areas, with the engine running, while smoking, or when near an open flame.**

Never overfill the tank or spill fuel. If fuel is spilled, clean it up immediately.

Be sure to use the correct type and grade of fuel.

Ground the fuel funnel or nozzle against the filler neck to prevent sparks that could ignite fuel vapors. Be sure to replace the fuel fill cap (if equipped) when you are done.

## Ultra-Low Sulfur Diesel (ULSD) Fuel Hazard

### Avoid Static Electricity Risk When Fueling

**⚠ WARNING!** Ultra-Low Sulfur Diesel (ULSD) poses a greater static ignition hazard than earlier diesel formulations with higher sulfur content. Avoid death or serious injury from fire or explosion; **consult with your fuel or fuel system supplier to ensure the delivery system is in compliance with fueling standards for proper grounding and bonding practices.**

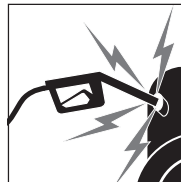

Static discharge during fueling can cause explosion

15

# Prepare for Safe Operation

## Know the Working Area

Learn as much about your working area as possible.

### Check at Ground or Floor Level

Inspect the surface over which you will travel. Look for holes, drop-offs and obstacles. Look for rough spots or hidden obstacles on surfaces which could cause a collision or loss of control. Look for weak spots on docks, ramps or floors. Look for oil spills, wet spots, and slippery surfaces. Look for soft soil, deep mud or standing water. Watch for anything that might make you lose control or cause the machine to roll over.

When operating inside a building, make certain you are within weight limitations of floors and ramps. Be aware of overhead clearances, doorways, aisles, etc. Plan travel routes ahead of time, in order to make sure you can see and protect bystanders. Pick up debris that can puncture tires.

Be observant of other workers, bystanders, and other machines in the area.

Remember, the danger of sliding and/or tipping on steep slopes is always present, regardless of how heavy or stable your machine may appear to be. Always use seat belts if a ROPS is equipped.

## Check Overhead

Check the clearances of doorways, canopies, and overheads. Know exactly how much clearance you have under power and telephone cables.

**⚠ DANGER!** Contact with energized power lines will cause serious injury or death. **Never approach overhead power lines with any part of your machine unless all local, state/provincial and national (OSHA) required safety precautions have been taken.** Always use extreme caution around power lines.

Know your margin of safety. If possible, have power to lines disconnected. If not possible, request a signal person for guidance.

**⚠ DANGER!** Electrocutation will result from touching or being near a machine that is in contact with, or near, an electrical source. **Stay away from any machine in contact with electrical wires until you are told it is safe to approach.**

# Start Safely

## Mount and Dismount Properly

Always use three-point contact when mounting or dismounting the machine. Three-point contact means one hand and two feet, or two hands and one foot, in contact with the machine at all times.

Never mount or dismount while carrying tools or objects that prevent three-point contact. Put parts or tools down. Maintain proper contact, climb or dismount, and then pick up the object.

Face the machine when you enter or leave the machine.

Clean shoes and wipe hands. Clean steps and handholds of chemical residue, snow, ice, mud or oil.

During mounting and dismounting:

- Use handholds and step plates.
- Never use steering wheels, joysticks or controls as handholds.
- Never jump on or off the machine.
- Never mount or dismount from a moving machine.

## Warn Personnel Before Starting

Before starting, walk completely around the machine. **Make sure no one is under the machine, on it, or close to it.** Let others know you are starting up and don't start until everyone is completely clear of the machine. As the equipment operator, you are responsible for the safe use of the machine, so always make sure you have communicated your work plans to others on the site.



Use three points of contact when mounting or dismounting



Avoid falls, clean up slippery areas

17

# Start Safely

## Starting the Engine

**⚠ WARNING!** Start the engine from the operator's seat only. **Never attempt to start the engine by shorting across starter terminals.** The machine may move unexpectedly, which could cause serious injury or death to anyone in its path.

Before starting, walk completely around compactor. Know the exact starting procedure for your machine. See the manufacturer's operating manual(s) for starting.

- Sit in the operator's seat and adjust the seat so you can operate all the controls properly.
- Fasten the seat belt/operator restraint.
- Familiarize yourself with warning devices, gauges and operating controls.
- Make sure controls are in the neutral/locked position.
- Clear the area of all persons.
- Start the engine following the instructions in the manufacturer's operating manual(s).
- If necessary to run the engine or operate the machine within an enclosed area, be sure there is adequate ventilation.

**⚠ WARNING!** Exhaust fumes can kill. **Do not breathe exhaust fumes!**

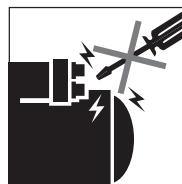

Never start engine by shorting across starter terminals

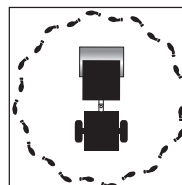

Before starting, walk completely around compactor

## Starting Aids

Ether/cold start fluid is **HIGHLY FLAMMABLE**. Before using it, always read the instructions on the ether/cold start fluid container and the instructions in the manufacturer's operating manual(s).

**⚠ WARNING!** Avoid injury from explosion or fire. If the engine is equipped with a glow plug pre-heater or other intake manifold type pre-heater, follow manufacturer's instructions before using ether/cold start fluid.

If you have trouble starting the engine and need to use jumper cables, follow the instructions in manufacturer's

# Start Safely

operating manual(s). **Jump-starting is a two-person operation.** The operator must be in the operator's seat when jump-starting so the machine will be under control when the engine starts. Wear appropriate PPE before attempting to jump-start your machine.

**⚠ WARNING!** A battery explosion or a run-away machine could result from improper jump-starting procedures. (See page 38, **Battery Hazards.**)

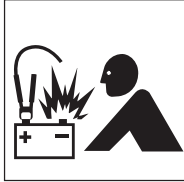

To avoid explosion, follow proper jump-starting procedures

## After Starting Engine

Observe gauges, instruments, and warning lights to assure that they are functioning and their readings are within the operating range.

## Run an Operating Check

Do not use a machine that is not in proper operating condition. It is your responsibility to check the condition of all systems and to run the check in a safe area.

## Test Controls

Roller compactors come equipped with various control configurations, patterns and operating modes, each with their own handling characteristics. Some have selectable or configurable controls, to suit personal preferences or specific applications. Make sure that you know which control pattern you have selected and that you understand how the machine will handle when using that control pattern.

Make sure the machine is operating properly by doing the following:

- With the control levers or joysticks in neutral, test engine speed control.
- Operate each pedal, lever or joystick to make sure all functions are correct.
- Operate the travel control lever(s) or joysticks to ensure correct operation in forward and reverse. Test steering to the right and to the left, while moving slowly in a clear, safe area.

**⚠ WARNING!** Before operating the machine under working conditions, **be certain you can control both the speed and direction of the machine.** Any loss of control could result in death or serious injury.

19

# Operate Safely

## Masked Visibility Areas

Machines have areas where the operator's visibility of the job site can be affected by the machine itself. ROPS posts, attachments, a drum, even items in the cab, could limit your view of the surrounding area and possibly mask hazards or people around you. These masked visibility areas vary from machine to machine, and it is very important you be aware of these areas before operating your machine.

Follow these safety precautions to reduce the hazards posed by masked visibility areas:

- Look around the machine before operating. Objects near the machine and close to the ground can be difficult to see from the cab.
- Always look in the direction of travel, including reverse. A back-up alarm is no substitute for looking behind you when operating the machine in reverse.
- Keep bystanders away, even if your machine is equipped with a back-up alarm.

## Remember These Rules

Never allow untrained, unqualified, or unauthorized personnel to operate your machine.

Never allow other personnel to ride on your machine unless appropriate seating is provided, and then, only if authorized to do so.

Never abuse your machine. Misuse or abuse can cause an accident.

## Articulated Machines

Never enter or place any part of your body in the "hitch area" or "pinch areas" of an articulated machine while the engine is running, or when there is any chance another person could start the machine.

If available, use the articulated joint lock during maintenance work, transportation, etc.

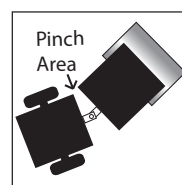

Keep body parts away from pinch area



# Operate Safely

## Work on Slopes Safely

When working on slopes, avoid side-hill travel whenever possible. It is generally safer to operate up and down the slope. Remember the danger of sliding and/or tipping on steep slopes is always present, regardless of how heavy or stable your machine may appear to be.

Always use seat belts if your machine is equipped with a ROPS. If equipped, make sure foldable ROPS is upright. Keep your hands and feet inside the cab at all times.

When climbing or descending steep grades, select the proper gear before starting on the slope, to assure adequate power or engine braking.

If your machine has a gear shift, select a low gear. If your machine has a hydrostatic drive, the speed control should be in the slow travel position, close to neutral, not in the fully displaced position.

On machines that have a gear shift and a hydrostatic control, both controls must be in their slow travel position.

Always be sure that manually operated gear type transmissions are fully engaged before starting onto a grade. Do not attempt to change the gear selection while traveling on a grade. See the manufacturer's manual for specific instructions.

## Watch Out for Hazardous Working Conditions

Be alert for hazards. Know where you are at all times. Watch for overhead obstacles. Look up as well as down.

Avoid operating your machine too close to an overhang, deep ditch or hole. If your machine inadvertently gets close to a tipping condition or drop-off, STOP and get off the machine after applying the parking brake. Plan your moves carefully before proceeding. Reversal is often the best move.

**⚠ WARNING! Never operate the machine close to the edge of an overhang or gully.** The edges could collapse or a slide could occur causing serious injury or death.

### Stay Alert! Rough Terrain Can be Hazardous!

Be alert to obstacles and excessively rough terrain. Back away from them and go around.

Always travel slowly over rough terrain and hillsides. Maintain a speed consistent with the working conditions.

21

# Operate Safely

## Follow Safe Operating Practices

Make these safe practices part of your daily routine:

- Keep your seat belt/operator restraint fastened.
- Never leave the operator's seat without having the unit come to a complete stop and applying the breaks.
- Operate the controls smoothly — don't jerk the steering levers or joysticks.
- Avoid sudden stops, starts or turns.
- Use care and good judgment.
- Never attempt to operate the controls unless properly seated in the cab.
- To shut down the machine, stop the engine and remove the ignition key, if equipped. (See page 30, **Safe Shutdown.**)

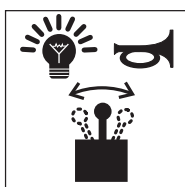

Operate  
instruments  
and controls  
smoothly

**⚠ WARNING!** Avoid Serious injury or death! **Keep your entire body inside the operator's cab while operating the machine.** Never work with your head, arms, feet or legs beyond the operator's compartment.

## Traveling on Jobsite

Take it slow and easy when traveling through congested areas. Traffic courtesy pays off.

Give the right-of-way to loaded machines. Maintain a safe distance from other machines. Pass cautiously.

Don't obstruct your vision when traveling or working. (See page 20, **Masked Visibility Areas.**) Operate at speeds slow enough so you have complete control at all times. If possible, avoid travel over rough, slippery or uneven terrain, and on hillsides.

## Travel Safely

When roading the machine, know your approximate stopping distance at any given speed.

Travel at controlled speeds, especially around corners.

Look in all directions before reversing your direction of travel.

Never coast in neutral.

# Operate Safely

Avoid steep slopes or unstable surfaces. If you must drive on a slope, travel at an appropriate speed and with extreme caution. Do not drive across an excessively steep slope under any circumstances. Travel straight up and down the slope. Before operating on slopes, check the surface conditions for adequate traction. Loss of traction can cause the machine to slide and tip.

**⚠ WARNING!** Avoid death or serious injury. **Travel up and down slopes with the heavy end of the machine pointed uphill.**

Check machine manufacturer's recommendations.

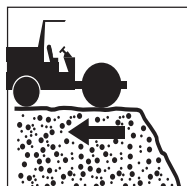

Operate perpendicular to banks – stay back from the edge

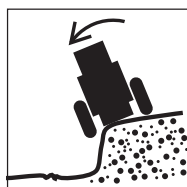

Use caution – stay safely away from bank or excavation edge

## Rules of the Road

When traveling on public roads or streets, obey all traffic regulations applicable to machine use and classification.

Make sure lights and warning signs are in place and visible. Make sure a SMV emblem is installed and visible to any vehicle approaching from the rear.

Find out if you must use an escort vehicle. Approach intersections with caution; observe speed and traffic control signs. Avoid panic stops and sharp turns.

Like any responsible operator, be considerate of other drivers. If traffic backs up behind you, it is a good idea to pull over periodically and allow traffic to pass when it is safe to do so.

Stop at all railroad crossings and look both ways before proceeding. Never park in traffic areas. If it is necessary to stop at night, pull off the road and set up flares or reflectors. When driving at night, use appropriate lights.

## Watch Out for Obstacles

Adjust your speed to conditions. Avoid crossing ditches, curbs or exposed railroad tracks. If obstacles are unavoidable, reduce speed and cross at an angle.

23

# Operate Safely

Keep your machine under control. Keep speed to a minimum when visibility is poor.

Before entering underpasses, tunnels or bunkers, check for oncoming traffic or obstructions.



Obey traffic regulations

## Work at Night Safely

Night operations require additional precautions to stay safe. Pay close attention and stay alert. Others passing through the work site may not be aware of hazards.

Plan the job, communicate the plan and inspect the work area during daylight. Mark obstacles ahead of time with reflective material.

Wear appropriate reflective apparel at all times – for operators and crew on night operations.

Ensure visibility of gauges and controls.

Ensure adequate lighting to illuminate work zone in compliance with state and local regulations and requirements.

Ensure adequate hazard lights (strobe or flashing/rotating lights) in compliance with state and local regulations and requirements.

Utilize direct line of sight, not mirrors, when working at night. Use spotters when direct line of sight is not possible. Lights can reflect in mirrors, causing a hazard to be unseen, or a masked visibility area.

Lack of natural light will impact visibility and may increase the risk of being backed over by vehicles or equipment.

Adjust work lights to minimize glare for traffic and workers.

Know where the other workers are at all times. Tell others where you are going.

Beware of fatigue. Check on crew members.

Stay in assigned work zones.

Enter and exit machine on side away from traffic, if possible.



# Operate Safely

## Exhaust Fumes in a Closed Space Can Kill

Vent exhaust and assure a flow of fresh air when an internal combustion engine is used in a closed space.

**⚠ WARNING!** Exhaust fumes can kill. **Do not breath exhaust fumes from any kind of engine.**

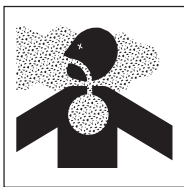

## Operating in Flammable/Explosive Atmospheres

**⚠ WARNING!** A roller compactor cannot be operated in flammable or explosive atmospheres.

Use in explosive atmospheres can result in fires and/or explosions which could cause serious injury or death.

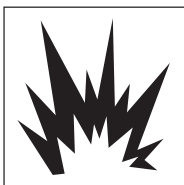

## Loading and Unloading Safely

Always wear your seat belt/operator restraint when loading or unloading your machine from a transport device, such as a flatbed truck.

When transporting a compactor, follow the manufacturer's recommended loading and unloading procedures.

Extreme care should be exercised when loading or unloading a walk-behind roller. It is generally best to stand behind and off to one side rather than directly behind a machine moving up or down a ramp.

Several precautions are applicable to all machines:

- Never load or unload a machine by yourself.
- Keep bystanders away.
- Load and unload on a level surface.
- Maintain proper visibility by loading or unloading in well-lit areas, and away from other vehicles, equipment or buildings.
- Block transport vehicle with wheel chocks so it cannot move.
- Ensure trailer bed and ramps are in good condition.
- Use ramps of adequate size and strength, with a low angle and proper height.

25

# Operate Safely

- Rear of trailer must be blocked or supported.
- Keep trailer bed and ramps free of clay, oil, ice, snow, and other materials which could become slippery.
- Chain and block the machine securely for transport. Use tie-down points as marked on the machine by the manufacturer. Follow the manufacturer's instructions in the operator's manual for tying down.
- Cover or remove rear-facing SMV sign on the roller compactor, if equipped, to avoid confusing drivers following the transport vehicle.
- Unload the machine by driving off in the opposite direction; do not turn the machine around.

## Transporting Safety Tips

### General

When towing a machine on a trailer, or a machine equipped with "portability or transport wheels," always use a hauling vehicle of sufficient weight, horsepower and braking capacity to maintain proper control.

Never attempt to tow a trailer or machine if the hitching devices are of insufficient or questionable capacity, improperly matched in size or shape, or positioned at improper heights.

When towing a machine equipped with portability or transport wheels, always follow the manufacturer's towing instructions.

### Before Towing

When connecting a trailer to a hauling vehicle, block under the trailer's tongue before attempting to make the connection. Never attempt to lift heavy tongues or move heavy trailers by hand. Never get any part of your body under the tongues when hitching or unhitching.

Make sure the hitch pin is of the proper size and securely locked in place before towing.

If the roller is designed to hang from the tailgate of a vehicle when being transported, be certain the hook brackets meet the roller manufacturer's specifications.

Use tow bars between the hauling vehicle and trailer or towed machine. Be sure the chains are properly and securely connected at both ends. Cross the chains under the tongues when connecting to the hauling vehicle.

Make sure electrical and other connections between the hauling vehicle and trailer or towed machine are properly and securely made. After connecting, check the lights for proper operation. If the towed trailer or

# Operate Safely

machine is equipped with brakes operable from the hauling vehicle, check to make sure they are operating properly.

Always be sure the portability or transport wheels, on machines so equipped, are locked in the lowered position.

Check all tires for proper pressure, excessive or abnormal wear, and potentially dangerous cuts, bruises or bulges. Have any problems corrected before proceeding.

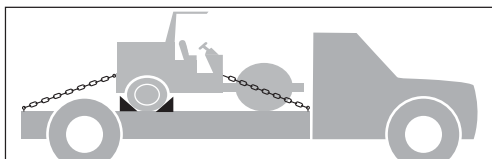

**Chain and block compactor securely for transport**

## Towing

Use care when towing a trailer or machine when:

- Maneuvering in tight places
- Backing (visibility is reduced, and jackknifing must be avoided)
- Towing on steep grades.

Know and obey all local, state and federal laws and regulations.

Do not travel at speeds above those recommended by the manufacturer.

Do not allow anyone to ride on a trailer or towed machine.

When necessary to disconnect and park a trailer or towed machine, select a location that is level and, if possible, where children are unlikely to be present. Before disconnecting a trailer, block the front AND rear of the wheels and block under the tongues.

27

# Operate Safely

## Walk-Behind Rollers

### Start-up

Only operate a walk-behind roller if you are thoroughly familiar with the manufacturer's operating instructions. If you have any questions or uncertainty, consult the manufacturer or dealer before attempting to operate it.

Always follow the manufacturer's instructions for starting the engine. All controls must be in the correct position before attempting to start the engine

Starting fluid is not recommended when hand starting an engine, because the engine may kick back, causing injury.

### Operation

When operating a walk-behind roller, exercise extreme care to avoid having your feet or clothing caught under the dolly wheels or roller. When possible, stand behind and off to one side of the machine, rather than directly behind it.

Particular care must be exercised when operating near obstructions and on slippery surfaces, grades and side slopes. Wear slip-resistant safety shoes or boots.

Do not ride on a walk-behind roller unless it is designed to accommodate riders and an appropriate seat is provided.

Do not attempt to shift on a grade if the roller has a mechanical transmission.

Do not operate a walk-behind roller in unshored trenches or near steep, unsupported banks. The vibrations could cause a cave-in.

Uneven grades can cause the handle to raise or lower unexpectedly, striking the unwary operator.

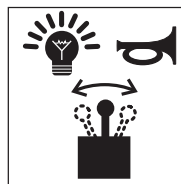

**Set all controls to correct position before starting the engine**

# Operate Safely

## Towed Rollers

Most general safety precautions covered earlier in this manual are also applicable to towed roller operation. There are many precautions specific to towed rollers that must be taken. Study your manufacturer's manual for instructions on your specific towed roller. Consult the manufacturer or dealer with any concerns.

Use a tow tractor of sufficient weight, drawbar horsepower and braking capacity to properly control the towed roller. Proper weight balance and distribution is also essential.

Block under the tongues of the towed roller before attempting to connect it to the towing vehicles or machine. Do not attempt to lift heavy tongues or move towed rollers by hand. Do not get any part of your body under the tongues when hitching or unhitching.

Make sure the hitch pin is of the proper size, and is securely locked in place before towing. If safety chains are provided, make sure they are properly and securely connected at both ends. Cross the chains under the tongues when connecting to the towing vehicle. Make sure all electrical or hydraulic connections are made properly and securely.

## Landfill Compactors

Operators of landfill compactors should carefully handle materials that could be picked up and thrown by the wheels, become lodged in the machine, or that are highly flammable.

Frequent checks should be made for wire, cable or other material wound around the axle members. Remove them immediately.

Travel with the blade as low as possible.

Maintain good operator visibility. Keep all mesh and windows free of accumulated materials.

When parking the machine, always lower the blade.

# Shut Down Safely

## Select a Proper Parking Site

Park in an off the road area, out of traffic, or as instructed. If necessary to park in a traffic lane, use the appropriate flags, barriers, flares, lights and warning signals. Provide advance warning signals in the traffic lane to warn approaching traffic.

Park on level ground whenever possible. When that's not possible, position the machine at right angles to the slope. Make sure the machine is on a firm footing, and that there is no danger of sliding. Do not leave your machine until you are sure it is safely blocked in both directions and parking brakes are firmly applied.

**⚠ WARNING!** Avoid death or serious injury. **Never leave the compactor unattended with the engine running.**

## Safe Shutdown

Know the proper shutdown procedure for your machine. As with the starting procedure, this varies with the type and model of machine.

If equipped, always lower the dozer blade when parking.

Follow the manufacturer's operation manual for your machine. Remove the key(s) to prevent unauthorized starting and movement, and position and lock any antivandalism devices.

## Dismount Properly

Make sure your machine is fully stopped and shut off before dismounting. When you leave the compactor, always maintain three-point contact with the steps and grab handles. Face the compactor as you dismount. Never jump off a machine.

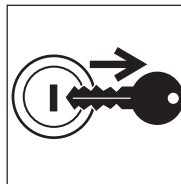

Shut engine off,  
remove key



Use three points  
of contact when  
mounting or  
dismounting

# Perform Maintenance Safely

## Know What You're Doing

Maintenance on this type of machine is not for inexperienced or untrained personnel. It can be hazardous unless performed properly. Be sure you have the necessary skill, information, correct tools and proper equipment to do the job safely.

Be sure to maintain the equipment according to the manufacturer's instructions. Regularly check the operation of the protective and safety devices.

**Do not** perform any work on a machine unless you are authorized and qualified to do so.

If you have been authorized to perform maintenance, **read the manufacturer's operating and service manuals.** Study the instructions. Check the lubrication charts and examine all the instruction messages on the machine.

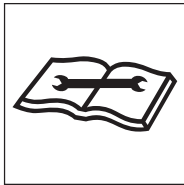

Maintain equipment

## Protect Yourself

Wear all the personal protective clothing and PPE issued to you or called for by job conditions or your supervisor.

You may need:

- Hard hat.
- Safety shoes.
- Safety glasses, goggles or face shield.
- Heavy duty gloves.
- Hearing protection.
- Reflective clothing.
- Wet weather gear.
- Respirator or filter mask.

Wear whatever is needed to protect yourself. Do not take chances.

# Perform Maintenance Safely

**⚠ WARNING!** Avoid death or serious injury from entanglement. **Do not wear loose clothing or accessories. Stay away from all rotating components when the engine is running.** Contact, wrapping or entanglement with rotating or moving parts could result in death or serious injury.

Wear a rubber apron and rubber gloves when working with corrosives. Wear gloves and safety shoes when handling wooden blocks or sharp-edged metal.

Always use safety glasses, goggles or a face shield. They provide eye protection from fluids under pressure, during grinding and while servicing batteries. Protection is also needed from flying debris, liquids and loose material produced by equipment, tools and pressurized air/water.

Wear a face shield and follow manufacturer's instructions when you disassemble spring-loaded components or work with battery acids. Keep pockets free of all objects that could fall out and drop into machinery.

Handle tools and heavy parts sensibly, with regard for the safety of yourself and others. Lower items; don't drop them.



Avoid rotating parts

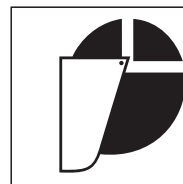

Wear eye protection



Do not loosen radiator cap until cool

# Perform Maintenance Safely

## Prepare the Work Area

- Position the machine on a level area out of the way of other working equipment.
- Make sure there is adequate light, ventilation and clearance.
- Remove oil, grease or water and dry slippery surfaces.
- Clean around the area to be serviced to minimize contamination.

## Prepare the Machine

Stored energy sources (electrical, mechanical, hydraulic, pneumatic, chemical, thermal, etc.) must be controlled or reduced to a practical minimum before performing any maintenance, repair, or service procedures.

Safety practices to prevent potential injuries from energy-releasing sources include:

- Place controls in NEUTRAL or LOCKED position before shutting off engine.
- Set parking brake or block wheels.
- Allow all moving parts to stop.
- Shut off engine.
- Relieve hydraulic system pressure by moving controls several times in all directions or per manufacturer's instructions.



Avoid falls, clean slippery surfaces

- Lock out the unit according to the manufacturer's manual.
- Attach a "DO NOT OPERATE" warning tag to the control levers.
- Lock ignition, remove key (if equipped) and take it with you.
- Look and listen for evidence of moving parts before dismounting.
- Shut off master electrical switch (if equipped).
- Disable the battery switch (if equipped).
- Securely support or block up machine or other components with approved locking devices before working underneath them.
- Relieve pressure before disconnecting or disassembling any pressurized system.
- Block or relieve spring pressure before disassembling any spring-loaded mechanism.
- Avoid flames, sparks, or smoking near any fuel, hydraulic fluid or other flammable material such as spraying debris.

33

# Perform Maintenance Safely

**⚠ WARNING!** Unsupported raised machines or other equipment may drop unexpectedly. **Never go under equipment when raised unless supported by an approved support device(s).** Death or serious crushing injury could result from falling equipment.

Remove only guards or covers that provide access to the area being serviced. Replace all broken or missing guards and covers when work is complete.

**⚠ WARNING!** Avoid injury or death. **Never work on machinery with the engine running unless instructed by the manufacturer's manuals for specific service.**



Use a "DO NOT OPERATE" tag

## Common Maintenance Safety Practices

### Use Proper Ventilation

If it is necessary to run an engine in an enclosed area, remove the exhaust fumes from the area with an exhaust pipe extension.

If you do not have an exhaust pipe extension, make sure you open doors and windows to get plenty of outside air into the area.

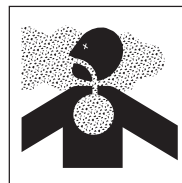

Ventilate work area

**⚠ WARNING!** Exhaust fumes contain carbon monoxide which could be deadly if inhaled. **Never operate any type of engine without proper ventilation.** EXHAUST FUMES CAN KILL.

# Perform Maintenance Safely

## Use Jacks and Hoists Carefully

Safety stands or blocks must be located on a rigid part of the machine. Do not position stands under axles or wheel supports that may rotate. Refer to manufacturer's manual.

**⚠ WARNING!** Prevent crushing injury. **Never use concrete blocks for supports. They could collapse under even light loads.**

If you must work beneath raised equipment, always use wood blocks, jack-stands or other rigid and stable supports. When using jacks or hoists, always be sure they are adequately supported.

Make sure the hoists or jacks you use are in good repair. Never use jacks with cracked, bent, or twisted parts. Never use frayed, twisted or pinched cables. Never use bent or distorted hooks.



**Avoid crushing, use proper support for raised equipment.**

## Fuel Hazards

**⚠ WARNING!** Avoid serious injury or death. **Always use approved fuel containers and/or fuel dispensing equipment to reduce the risk of explosion or fire.**



**No smoking and no open flames**

Always observe these practices to reduce the possibility of a serious accident:

- Shut off engine and ignition during refueling.
- Always ground the fuel nozzle against the filler neck to avoid sparks.
- Keep sparks and open flames away from fuel.
- Do not smoke while refueling or when handling fuel containers.
- Do not cut or weld on or near fuel lines, tanks or containers.
- Do not overfill the tank or spill fuel. Clean up spilled fuel immediately.

35

# Perform Maintenance Safely

## Ultra-Low Sulfur Diesel (ULSD) Hazard

**⚠ WARNING!** Ultra-Low Sulfur Diesel (ULSD) poses a greater static ignition hazard than earlier diesel formulations. Avoid death or serious injury from fire or explosion; **consult with your fuel or fuel system supplier to ensure the delivery system is in compliance with fueling standards for proper grounding and bonding practices.**

## Engine Coolant Hazards

**⚠ WARNING!** Avoid serious injury or death. Liquid cooling systems build up pressure as the engine gets hot, so **use extreme caution before removing the radiator cap.**

- Stop the engine and wait for the system to cool.
- Wear protective clothing and safety glasses.
- Turn the radiator cap slowly to the first stop to allow the pressure to escape before removing completely.



**Remove radiator cap slowly**

## Hydraulic System Hazards

Be sure to follow manufacturer's instructions for relieving fluid pressure before performing any maintenance. The hydraulic system is pressurized whenever the engine is on and may hold pressure even after the engine is shut off. Cycle hydraulic controls, including auxiliary hydraulic control (if equipped), after the engine is shut off.



**Check for leaks and inspect hoses**

During inspection of the hydraulic system:

- Wait for fluid to cool before disconnecting the lines. Hot hydraulic fluid can cause SEVERE BURNS.
- Wear appropriate eye protection. Hydraulic fluid can cause permanent eye injury.
- When venting or filling the hydraulic system, loosen the filler cap slowly and remove it gradually.
- **Never** reset any relief valve in the hydraulic system to a pressure higher than recommended by the manufacturer.



# Perform Maintenance Safely

## Hydraulic Fluid Injection Hazard



High pressure fluid  
can inject into  
the body

**⚠ WARNING!** Accidental injection of high-pressure oil into the hands or body is dangerous and could result in death or serious injury. **Use caution when checking hydraulic leaks as pressurized hydraulic fluid has enough force to penetrate skin, causing serious personal injury.**

If you discover a leak:

- Ensure engine is turned off; relieve pressure in hydraulic circuit.
- Wear proper hand and eye protection.
- Visually examine the hydraulic hoses or fluid lines in the vicinity of the leak for breaks or cracks. **Do not** use your hand to check for leaks.
- Repair or replace hydraulic lines according to the manufacturer's recommendations.

Fluid injection injuries are not always obvious. Victims have reported such injuries feel like a bee sting or splinter under the skin. If you suspect you have a fluid injection injury, do not take chances. Seek proper medical care immediately. If any fluid is injected into the skin, it must be surgically removed within a few hours by a doctor familiar with this type of injury.

## Diesel Particulate Filter Hazard

You may need to run an active regeneration on some machines with a diesel particulate filter (DPF). Running an active regeneration to clean a DPF can create extremely high temperatures. Consult your operator's manual for the proper procedure for running an active regeneration.

**⚠ WARNING!** Extremely high temperatures can cause a fire or explosion, so **do not run an active regeneration in an explosive or flammable atmosphere.**

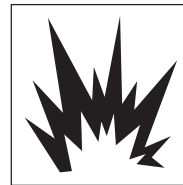

Do not operate in  
explosive/flammable  
atmosphere

37

# Perform Maintenance Safely

## Electrical System Hazards

### Light Bulbs and Illumination

Some machines are equipped with High-Intensity Discharge (HID) Xenon light bulbs which operate at very high voltage. Do not begin installation of HID-Xenon lamps unless the lamps are turned off, the engine is turned off, the key is removed (if equipped), and you are wearing appropriate eye protection.

**⚠ WARNING!** Do not look directly into HID-Xenon lamps. Eye damage could occur.

Wear gloves and safety glasses when handling bulbs. Dangerous voltage sparks may occur and cause injury or damage to the connector. See manufacturer's warnings packaged with replacement bulbs.

Before working on the electrical system, either hit the main power disconnect switch, if equipped, or disconnect the battery cable(s).

- Remove the battery negative (-) cable(s) first.
- When reconnecting the battery, connect the battery negative (-) cable(s) last.

## Battery Hazards

The liquid in batteries contains acid, which is a POISON and could cause SEVERE CHEMICAL BURNS.

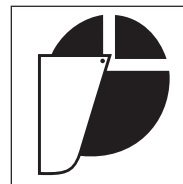

Wear face  
protection

Avoid injury:

- Wear a face shield to prevent contact with your eyes.
- Wear chemical-resistant gloves and clothing to keep liquid off your skin and regular clothing.

**⚠ WARNING!** Liquids in batteries will damage eyes or skin on contact. **Always wear a face shield to avoid getting liquid in your eyes.**

If liquid from the battery contacts your eyes, flush immediately with clean water and get medical attention. **Wear chemical-resistant gloves and protective clothing to keep liquid off your skin.** If liquid contacts skin or clothing, wash off immediately with clean water. **If liquid is ingested,** drink large quantities of water or milk. DO NOT induce vomiting. Seek medical attention immediately.

# Perform Maintenance Safely

## Avoid Explosion

**⚠ WARNING!** Avoid serious injury from explosion. Lead-acid batteries produce extremely explosive gases especially when being charged. **Keep arcs, sparks, flames and lighted tobacco away.**

- Do not smoke near batteries.
- Keep them away from arcs, sparks and open flames.
- Provide adequate ventilation.

**Never** check the battery by placing a metal object across the battery posts. The resulting spark could cause an explosion.

**⚠ WARNING!** Avoid serious injury from battery explosion. **Do not charge a battery or jump-start the engine if the battery is frozen.**

Warm to 60°F (15.5°C) or the battery may explode and could cause serious injury.

Safety rules during battery jump-starting:

- Follow the instructions for proper battery jump-starting, as specified in the manufacturer's manual.
- Be sure the machines are not touching.
- Observe the polarity of the batteries and connections.

- Make the final cable connection to the engine or the furthest ground point away from the battery. Never make the final connection at the starter or dead battery. Sparks may ignite the explosive gases present at the battery.
- When disconnecting cables, remove the cables in reverse order of connection (e.g., final connection first).

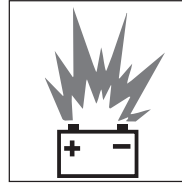

**Avoid sparks and open flames near batteries**

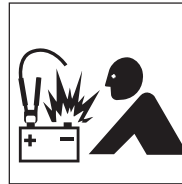

**When jump-starting, observe polarity and make final connection at ground point**

## Toxic Chemical Disposal

For the safety of others and the environment, consult with your operator's manual or site supervisor for proper disposal of batteries and any chemicals or fluids.

39

# Perform Maintenance Safely

## Tire and Wheel Maintenance

Check your tires and wheels daily, if equipped, because the stability of the machine can be dramatically affected by tire pressure or damage to tires or wheels.

Check tires for:

- Correct pressure.
- Cuts and bulges.
- Nails or other punctures.
- Uneven or excessive wear.
- Condition of valve stems and caps.

Check wheels for:

- Damage to the rims.
- Missing or loose lug nuts or bolts.
- Misalignment.

All tire service should be performed by a qualified tire service center or by an authorized service person who has been properly trained in the procedures and use of safety equipment designed for tire servicing.

**⚠ WARNING!** The types of wheels and tires usually found on this equipment require special care when servicing to prevent death or serious injury. **Do not inflate the tires above the recommended pressure.**

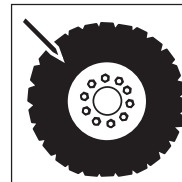

**Check tires and wheels for damage**

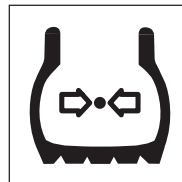

**Maintain proper tire pressure**



# Perform Maintenance Safely

Keep wheel lug nuts tightened to manufacturer's recommendations.

An increase in tire pressure during operation is normal, and should NOT be reduced.

Never reinflate a tire that has been run flat or seriously under-inflated without removing the tire from the wheel. Have the tire and wheel closely inspected for damage before remounting.



**Avoid tire explosion**

When adding air to a tire, do so from a distance. Always use a long hose with a self-attaching chuck; stand away from the tire sidewall and to one side as far as possible.

Do not inflate tires with flammable gases or from systems using an alcohol injector.

Never cut or weld on a wheel with an inflated tire mounted on it. This could cause explosive decompression.

Check that the tire size and wheel are correctly matched.

When replacing the tires, ensure the tires are of the appropriate rating specified by the manufacturer.

**⚠ WARNING!** Avoid death or serious injury. **Always use a safety cage or cable restraints when reinflating a repaired tire.**

Tires should not be operated at speeds higher than their rated speed.

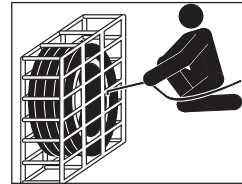

**Use safety devices when reinflating tires**

41

# Perform Maintenance Safely

## Roll-Over Protective Structure (ROPS) and Falling Object Protective Structure (FOPS) Safety Precautions

Do not remove the ROPS/FOPS except for service. Reinstall them correctly before allowing the machine back into service.

Do not modify ROPS/FOPS in any manner.

Unauthorized modifications such as welding, drilling, cutting or adding attachments could weaken the structure and reduce your protection. Replace ROPS/FOPS if subjected to rollover or damage. Do NOT attempt to repair them. See the manufacturer's manual(s) for complete instructions and inspection requirements.

If your machine is equipped with a foldable ROPS, make sure it is upright whenever the machine is in use.

## Complete Service and Repairs Before Machine is Released

Tighten all bolts, fittings, and connections to torques specified by the manufacturer.

Are there any missing cotter pins, washers, locknuts, etc.? Are there any parts left over?

Start the engine and check for leaks. (See page 36, **Hydraulic System Hazards**.) Operate all controls to make sure the machine is functioning properly. Test the machine if necessary. After testing, shut down and check the work you performed.

Recheck all fluid levels before releasing the equipment for operation.

All parts should be inspected during repair and replaced if worn, cracked or damaged. Excessively worn or damaged parts could fail and cause injury or death.

Install all guards, covers, and shields after servicing. Refill and recharge pressure systems only with manufacturer-approved or recommended fluids.



**Verify service work when completed**

# Final Word to the User

You have just finished reading the AEM Roller Compactor Safety Manual. It is impossible for this manual to cover every safety situation that you may encounter on a daily basis. Your knowledge of these safety precautions and your application to the basic rules of safety will help to build good judgment in all situations. Our objective is to help you develop, establish and maintain good safety habits to make operating a roller compactor easier and safer for you.

Many pictorials in this safety manual can be downloaded at <http://pictorials.aem.org>.

For additional publications, visit our website at [www.safetymaterials.org](http://www.safetymaterials.org).

43



ASSOCIATION OF  
EQUIPMENT MANUFACTURERS



e-mail [safetymaterials@aem.org](mailto:safetymaterials@aem.org)  
[www.aem.org](http://www.aem.org)

This manual is one in a series on the safe operation of machinery, published by AEM.



To order AEM safety materials  
visit [www.safetymaterials.org](http://www.safetymaterials.org).



16 Schematics—RD12A (Gasoline)

16.1 Hydraulic Schematic

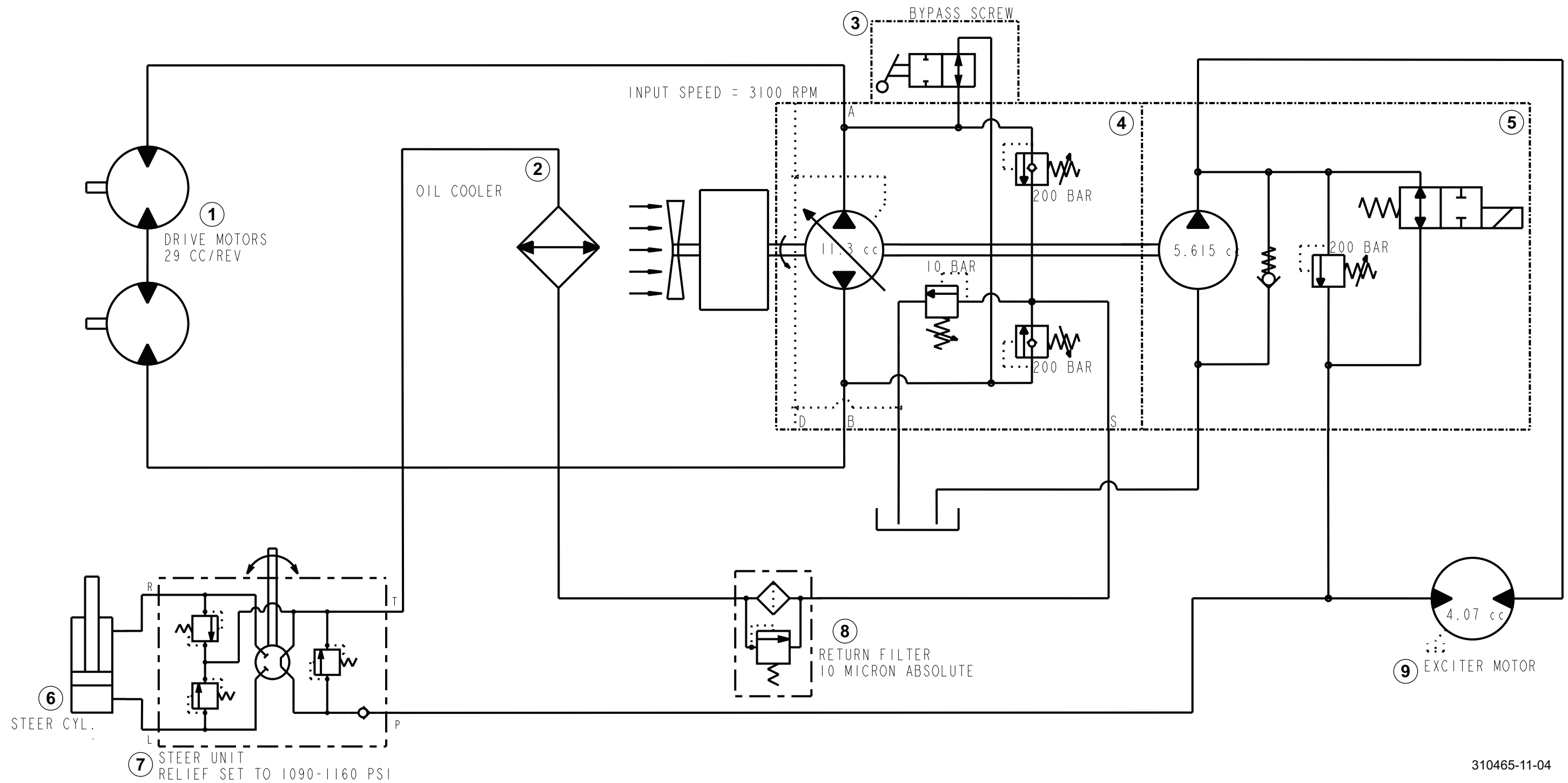

310465-11-04

## 16.2 Hydraulic Schematic Components

Ref.	Description	Ref.	Description
1	Drive motors	6	Steering cylinder
2	Oil Cooler	7	Steering unit
3	Bypass screw	8	Return filter
4	Main Pump	9	Exciter motor
5	Exciter Pump	—	—

16.3 Electrical Schematic

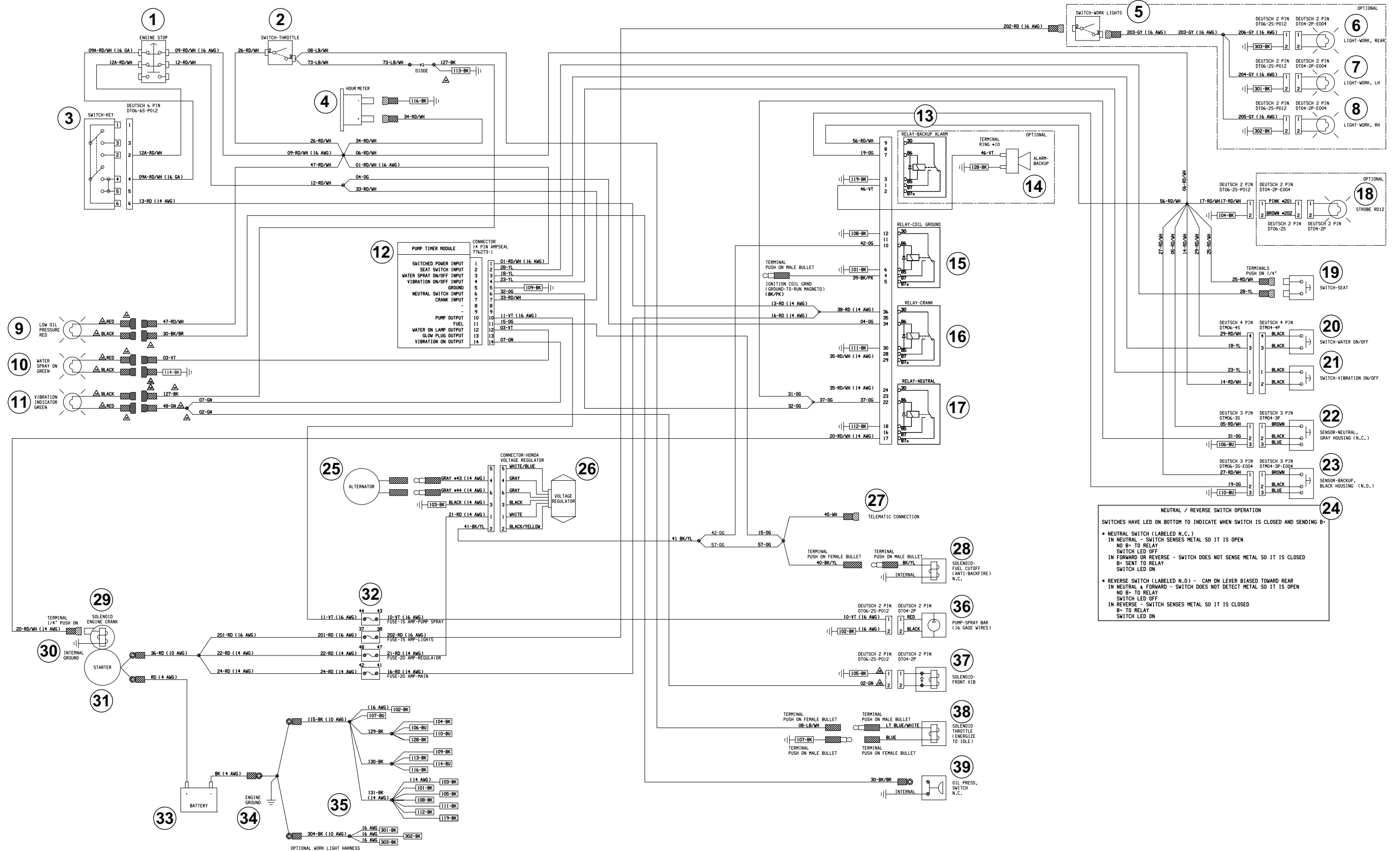

**NEUTRAL / REVERSE SWITCH OPERATION**

SWITCHES HAVE LED ON BOTTOM TO INDICATE WHEN SWITCH IS CLOSED AND SENDING B-

- NEUTRAL SWITCH (LABELED N.C.)  
IN NEUTRAL - SWITCH SENSES METAL SO IT IS OPEN  
NO B- TO RELAY  
SWITCH LED OFF  
IN FORWARD OR REVERSE - SWITCH DOES NOT SENSE METAL SO IT IS CLOSED  
B- SENT TO RELAY  
SWITCH LED ON
- REVERSE SWITCH (LABELED N.O.) - CAM ON LEVER BIASED TOWARD REAR  
IN NEUTRAL & FORWARD - SWITCH DOES NOT DETECT METAL SO IT IS OPEN  
NO B- TO RELAY  
SWITCH LED OFF  
IN REVERSE - SWITCH SENSES METAL SO IT IS CLOSED  
B- TO RELAY  
SWITCH LED ON

## 16.4 Electrical Schematic Components

Ref.	Description	Ref.	Description
1	Engine stop	18	Strobe light (optional)
2	Throttle switch	19	Seat switch
3	Key switch	20	Water switch
4	Hourmeter	21	Vibration switch
5	Work lights switch (optional)	22	Neutral switch
6	Rear work lights (optional)	23	Reverse switch
7	Left work light (optional)	24	Neutral / reverse switch operation  Switches have LED on bottom to indicate when switch is closed and sending B+ • Neutral switch (labeled N.C.) In neutral – switch senses metal so it is open No B+ to relay Switch LED off In forward or reverse – switch does not sense metal so it is closed B+ sent to relay Switch LED on • Reverse switch (labeled N.O.) – cam on lever biased toward rear In neutral and forward – switch does not detect metal so it is open No B+ to relay Switch LED off In reverse – switch senses metal so it is closed B+ to relay Switch LED on
8	Right work light (optional)		
9	Low oil pressure indicator light – red		
10	Water spray indicator light – green		
11	Vibration indicator light – green		
12	Pump timer module		
	1 – Switched power input		
	2 – Seat switch input		
	3 – Water spray ON-OFF input		
	4 – Vibration ON-OFF input		
	5 – Ground		
	6 – Neutral switch input		
	7 – Crank input		
8	—	25	Alternator
9	—	26	Voltage regulator
10	Pump output	27	Telematics connection
11	Fuel	28	Fuel cutoff solenoid
12	Water ON lamp output	29	Engine crank solenoid
13	Glow plug output	30	Internal ground
14	Vibration ON output	31	Starter
13	Backup alarm relay (optional)	32	Fuses
14	Backup alarm (optional)		
15	Ground coil relay		
16	Crank relay		
17	Neutral relay		
			15A – pump spray
			15A – lights
			20A – regulator
			20A – main

Ref.	Description	Ref.	Description
33	Battery	37	Front vibration solenoid
34	Engine ground	38	Throttle solenoid
35	Work light harness (optional)	39	Oil pressure switch
36	Spray bar pump	—	—





**Important:** For spare parts information, please see your Wacker Neuson Dealer, or visit the Wacker Neuson website at <http://www.wackerneuson.com/>.

**Wichtig!** Informationen über Ersatzteile erhalten Sie von Ihrem Wacker Neuson Händler oder besuchen Sie die Wacker Neuson Website unter <http://www.wackerneuson.com/>.

**Important :** Pour des informations sur les pièces détachées, merci de consulter votre distributeur Wacker Neuson, ou de visiter le site Internet de Wacker Neuson sur <http://www.wackerneuson.com/>.

**Importante :** Para saber más sobre las piezas de repuesto, póngase en contacto con su distribuidor de Wacker Neuson o acceda al sitio web de Wacker Neuson en <http://www.wackerneuson.com/>.

**Importante :** Per informazioni sui pezzi di ricambio, contattare il rivenditore Wacker Neuson o visitare il sito di Wacker Neuson all'indirizzo [www.wackerneuson.com](http://www.wackerneuson.com/).

**Viktigt :** För information om reservdelar, kontakta din Wacker Neuson-leverantör eller besök Wacker Neusons webbplats på <http://www.wackerneuson.com/>.

**Tärkeää :** Pyydä varaosatietoja Wacker Neusonin jälleenmyyjältä tai vieraile Wacker Neusonin web-sivustolla osoitteessa <http://www.wackerneuson.com/>

**Viktig :** For informasjon om reservedeler, vennligst kontakt din Wacker Neuson-forhandler, eller besøk Wacker Neusons nettside på <http://www.wackerneuson.com/>.

**Viktigt :** Hvis du ønsker oplysninger om reservedele, bedes du kontakte din Wacker Neuson forhandler eller besøg Wacker Neuson websiden på <http://www.wackerneuson.com/>.

**Belangrijk!** Neem contact op met uw Wacker Neuson dealer of bezoek de website van Wacker Neuson op <http://www.wackerneuson.com/> voor meer informatie over reserveonderdelen.

**Importante :** Para obter informações sobre as peças sobresselentes, consulte o seu fornecedor da Wacker Neuson ou acesse ao site Web da Wacker Neuson em [http://www.wackerneuson.com](http://www.wackerneuson.com/)

**Ważne :** W celu uzyskania informacji na temat części zamiennych skontaktuj się z przedstawicielem firmy Wacker Neuson lub skorzystaj z witryny internetowej <http://www.wackerneuson.com/>.

**Důležitě upozornění!** Pro informace o náhradních dílech, prosím, kontaktujte svého Wacker Neuson dealera, nebo navštivte webové stránky <http://www.wackerneuson.com/>.

**FONTOS:** A pótalkatrészekre vonatkozó információkért kérjük, forduljon Wacker Neuson kereskedőjéhez vagy látogasson el a Wacker Neuson weboldalára a következő címen: <http://www.wackerneuson.com/>.

**Важно!** Для ознакомления с информацией о запасных частях, пожалуйста, обратитесь к местному торговому представителю компании Wacker Neuson или посетите веб-сайт <http://www.wackerneuson.com/>.

**Σημαντικό :** Για πληροφορίες σχετικά με τα ανταλλακτικά, μιλήστε με τον αντιπρόσωπό σας της Wacker Neuson, ή επισκεφθείτε τον ιστότοπο <http://www.wackerneuson.com/>.

**Važno :** Za rezervne dijelove obratite se svom Wacker Neuson prodavaču ili posjetite mrežne stranice tvrtke Wacker Neuson: <http://www.wackerneuson.com/>.

**Önemli :** Yedek parça bilgileri için Wacker Neuson Bayinize bakın veya Wacker Neuson web sitesini ziyaret edin. <http://www.wackerneuson.com/>

**重要** 交換部品の情報については、ワッカーノイソンディーラーにお問い合わせ頂くか、ワッカーノイソンウェブサイト <http://www.wackerneuson.com/> をご覧ください。

**重要** 有关备件信息，请咨询您的威克诺森经销商或访问威克诺森网站：  
<http://www.wackerneuson.com/>。

**Important :** Pentru informații referitoare la piesele de schimb, vă rugăm să vă adresați distribuitorului Wacker Neuson sau să vizitați site-ul web Wacker Neuson la adresa <http://www.wackerneuson.com/>.

**Важно :** За информация относно резервни части, моля, обърнете се към местния дилър на Wacker Neuson или посетете уебсайта на Wacker Neuson на адрес <http://www.wackerneuson.com/>.

---

Wacker Neuson Produktion GmbH & Co. KG, Preußenstraße 41, D-80809 München,

Tel.: +49-(0)89-3 54 02-0 Fax: +49 - (0)89-3 54 02-390

Wacker Neuson Production Americas LLC, N92W15000 Anthony Ave., Menomonee Falls, WI. 53051

Tel.: (262) 255-0500 Fax: (262) 255-0550 Tel.: (800) 770-0957

Wacker Neuson Limited - Room 1701-03 & 1717-20, 17/F, Tower 1, Grand Century Place, 193 Prince Edward Road West, Mongkok, Kowloon, Hongkong. Tel: (852) 3605 5360, Fax: (852) 2758 0032

