

RTX100

Trencher

Operator's

Manual



RTX100_o2_02
Serial No. 1001-
Order No. 105400BN3
Cabled Assembly No. 296338869

Vermeer[®]

Introduction

This manual explains the proper operation of your machine. Study and understand these instructions thoroughly before operating or maintaining the machine. Failure to do so could result in personal injury or equipment damage. Consult your Vermeer dealer if you do not understand the instructions in this manual, or need additional information.

The instructions, illustrations, and specifications in this manual are based on the latest information available at time of publication. Your machine may have product improvements and features not yet contained in this manual.

Vermeer Corporation reserves the right to make changes at any time without notice or obligation.

Operation instructions are included in the two Operator's Manuals provided with the machine. The tethered (cabled) manual must remain attached to the machine for ready reference. Store it in the manual storage box when not in use.

Lubrication and maintenance procedures are in the Maintenance Manual provided with the machine. Refer to it for all lubrication and maintenance procedures.

Additional copies of the manuals are available from your dealer. Use the reorder number on the front cover to order additional manuals.

Copies of this manual are available in Spanish from your dealer.

Se dispone de ejemplares de este manual en español.

NOTICE TO OWNER

You are requested to notify Vermeer Corporation when you have purchased a **used** Vermeer machine. Notify the Customer Data Department by telephone: 800-829-0051 or 641-628-3141; email: customerdata@vermeer.com; internet: www.vermeer.com or www.vermeerag.com; or letter: Customer Data Dept., Vermeer Corporation, PO Box 200, Pella IA 50219 USA. Upon request, an owner of a used Vermeer machine will receive one free set of Operator's, Maintenance and Parts manuals.



NOTE: Right and left sides of the machine are determined by facing in the direction of forward travel. The attachment is at the front.

TRADEMARKS

VERMEER and **VERMEER** Logo are trademarks of Vermeer Manufacturing Company.

Honda is a trademark of Honda Motor Co. Ltd.

Kohler is a trademark of Kohler Co.

VERMEER NEW INDUSTRIAL EQUIPMENT LIMITED WARRANTY

(EFFECTIVE OCTOBER 1, 2008)

WARRANTY PERIOD: 12 Months / 1000 Hours

Vermeer Corporation (hereinafter "Vermeer") warrants each new Industrial product of Vermeer's manufacture to be free from defects in material and workmanship, under normal use and service for one (1) full year after initial purchase/retail sale or 1000 operating hours, whichever occurs first. This Limited Warranty shall apply only to complete machines of Vermeer's manufacture, parts are covered by a separate Limited Warranty. **EQUIPMENT AND ACCESSORIES NOT OF VERMEER'S MANUFACTURE ARE WARRANTED ONLY TO THE EXTENT OF THE ORIGINAL MANUFACTURER'S WARRANTY AND SUBJECT TO THEIR ALLOWANCE TO VERMEER ONLY IF FOUND DEFECTIVE BY SUCH MANUFACTURER.**

EXTENDED WARRANTY OPTIONS ARE AVAILABLE FOR PURCHASE.

WARRANTY TERMS

During the Limited Warranty period specified above, any defect in material or workmanship in any warranted item of Vermeer Industrial Equipment not excluded below shall be repaired or replaced at Vermeer's option without charge by any authorized independent Vermeer dealer. The warranty repair or replacement must be made by a Vermeer independent authorized dealer at the dealer's location. Vermeer will pay for replacement parts and such authorized dealer's labor in accordance with Vermeer's labor reimbursement policy. Vermeer reserves the right to supply remanufactured replacement parts as it deems appropriate.

RETAIL PURCHASER RESPONSIBILITY: This Limited Warranty requires proper maintenance and periodic inspections of the Industrial Equipment as indicated in the Operator's/Maintenance Manual furnished with each new Industrial Equipment. The cost of routine or required maintenance and services is the responsibility of the retail purchaser. The retail purchaser is required to keep documented evidence that these services were performed.

This Vermeer New Industrial Equipment Limited Warranty may be subject to cancellation if the above requirements are not performed.

Vermeer Industrial Equipment with known failed or defective parts must be immediately removed from service.

EXCLUSIONS AND LIMITATIONS

The warranties contained herein shall **NOT APPLY TO:**

- (1) Any defect which was caused (in Vermeer's sole judgment) by other than normal use and service of the Industrial Equipment, or by any of the following; (i) accident (ii) misuse or negligence (iii) overloading (iv) lack of reasonable and proper maintenance (v) improper repair or installation (vi) unsuitable storage (vii) non-Vermeer approved alteration or modification (viii) natural calamities (ix) vandalism (x) parts or accessories installed on Industrial Equipment which were not manufactured or installed by Vermeer authorized dealers (xi) the elements (xii) collision or other accident.
- (2) Any Industrial Equipment whose identification numbers or marks have been altered or removed or whose hourmeter has been altered or tampered with.
- (3) Any Industrial Equipment which any of the required or recommended periodic inspection or services have been performed using parts not manufactured or supplied by Vermeer or meeting Vermeer Specifications including, but without limitation, engine tune-up parts, engine oil filters, air filters, hydraulic oil filters, and fuel filters.
- (4) New Industrial Equipment delivered to the retail purchaser in which the warranty registration has not been completed and returned to Vermeer within ten (10) days from the date of purchase.
- (5) Any defect which was caused (in Vermeer's sole judgment) by operation of the Industrial Equipment not abiding by standard operating procedures outlined in the Operator's Manual.
- (6) Engine, battery, and tire Limited Warranties and support are the responsibility of the respective product's manufacturer.
- (7) Transportation costs, if any, of transporting to the Vermeer dealer. Freight costs, if any, of transporting replacement parts to the Vermeer dealer.
- (8) The travel time of the Vermeer dealer's service personnel to make a repair on the retail purchaser's site or other location.
- (9) In no event shall Vermeer's liability exceed the purchase price of the product,
- (10) Vermeer shall not be liable to any person under any circumstances for any incidental or consequential damages (including but not limited to, loss of profits, out of service time) occurring for any reason at any time.
- (11) Diagnostic and overtime labor premiums are not covered under this Limited Warranty Policy. Oils and fluids are not covered under this Limited Warranty.

- (12) Depreciation damage caused by normal wear, lack of reasonable and proper maintenance, failure to follow operating instructions, misuse, lack of proper protection during storage.
- (13) Accessory systems and electronics not of Vermeer's manufacture are warranted only to the extent of such manufacturer's respective Limited Warranty if any.
- (14) Downhole toolage is not covered under this warranty.
- (15) Wear items which are listed by product group as follows:

ENVIRONMENTAL: Bearing Seals, Bearings, Belts, Brake Pads, Bolts/Torqued Parts, Chain, Clutches, Clutch Components, Curtains, Cutter Wheels, Discharge Conveyor Belts, Fuel Filters, Hammers, Hoses, Infeed Conveyor Belts, Infeed Conveyor Chains, Knives, Oil Filters, Pockets, Rods, Rollers, Rotor Plates, Screens, Service Items, Shear Bar/Bedknife, Sprockets, Teeth, Wear Blocks, Wear Strips.

TRACK: Base Plates, Boom Wear Items, Buckets, Cable Fingers, Conveyor Belts, Clutches, Cups, Digging Chain, Digging Rims, Drums, End Idler, Flashings, Pins and Bushings, Pivot Rings, Plastic Wear Strips, Rooter Bands, Scraper Knives, Sprockets, Teeth, Track Chain, Track Rollers, Trench Cleaner (Crumber), Trip Cleaners, Truck Rollers, Wear Plates.

TRENCHLESS: Brushes, Clamping Vise Parts, Dies, Drive Chuck, Earth Stakes, Fan Belts, Jaws, Leaf Chain, Lights On Light Kits, Packing Assemblies, Rod, Rod Loader Parts, Rollers, Tooling, Track Chain, Track Guides, Track Idlers, Track Pads, Track Sprockets, Valve Seats, Wear Bars, Wear Blocks, Water Hoses, Water Swivels, Wear Bars.

UTILITY PRODUCTS: Augers, Belts, Bearings, Booms, Brake Pads, Bucket, Bushings, Chains, Clutches, Conveyor Belts, End Rollers, Flashings, Pins, Pivot Rings, Plow Blades, Rubber Shielding, Sprockets, Teeth, Tires, Track Chain, Track Idlers, Track Sprockets, Trench Cleaner (Crumber).

PARTS WARRANTY:

Parts replaced in the warranty period will receive the balance of the first year New Industrial Equipment Limited Warranty, during the first (12) months or 1000 hours, whichever comes first. Replacement parts after the original machine warranty, are warranted to be free from defects of material for ninety (90) days or the part will be repaired or replaced, without labor coverage for removal and reinstallation.

EXCLUSIONS OF WARRANTIES: EXCEPT FOR THE WARRANTIES EXPRESSLY AND SPECIFICALLY MADE HEREIN, VERMEER MAKES NO OTHER WARRANTIES, AND ANY POSSIBLE LIABILITY OF VERMEER HEREINUNDER IS IN LIEU OF ALL OTHER WARRANTIES, EXPRESS, IMPLIED, OR STATUTORY, INCLUDING, BUT NOT LIMITED TO, ANY WARRANTIES OF MERCHANTABILITY OR FITNESS FOR A PARTICULAR PURPOSE. VERMEER RESERVES THE RIGHT TO MODIFY, ALTER AND IMPROVE ANY PRODUCT WITHOUT INCURRING ANY OBLIGATION TO REPLACE ANY PRODUCT PREVIOUSLY SOLD WITH SUCH MODIFICATION. NO PERSON IS AUTHORIZED TO GIVE ANY OTHER WARRANTY, OR TO ASSUME ANY ADDITIONAL OBLIGATION ON VERMEER'S BEHALF.

NO DEALER WARRANTY. The selling dealer makes no warranty of its own and the dealer has no authority to make any representation or promise on behalf of Vermeer or to modify the terms or limitations of this warranty in any way.

**MANUFACTURED BY:
VERMEER CORPORATION
Pella, Iowa 50219 USA**

This page intentionally left blank.

Receiving and Delivery Report

DEALER PREP

Check or perform the following:

- ___ Check machine for shortage or damage in transit.
- ___ Check adjustment of trencher digging chain and auger.
- ___ Check installation and adjustment of trencher restraint bar.
- ___ Check installation and condition of all shields.
- ___ Check machine for proper lubrication.
- ___ Check condition of all safety signs and decals.
- ___ Check all phases of operation.
- ___ Check for loose hardware.
- ___ Check adjustment and operation of neutral start switches.
- ___ Check battery condition and terminal connections (if equipped).
- ___ Check that Operator's Manual is cabled to the machine.
- ___ Check wheel lug nuts tightness (60 ft-lb/80 Nm).
- ___ Check drive wheel tires (if equipped) for proper air pressure: 12 psi (83 kPa) maximum.
- ___ Check track tension (if equipped).
- ___ Check handgrip Operator Presence control for proper operation.
- ___ Check that machine does not move when the ground drive lever is in NEUTRAL and engine is at full throttle.
- ___ Check that digging chain does not move when digging chain drive lever is in NEUTRAL and engine is at full throttle.

Engine

- ___ Check oil level of the engine.
- ___ Check condition of the air cleaner.
- ___ Check engine for proper operation.

Hydraulics

- ___ Check hydraulic fluid level.
- ___ Check control levers for proper operation.
- ___ Check all hydraulic components for leaks or damage.

Review of Operation

Review and demonstrate with the customer the various aspects of tractor operation:

- ___ overall explanation of how the machine works
- ___ overall explanation of how trencher works
- ___ tractor and trencher safety
- ___ preparing the machine and trencher for operation

DEALER/CUSTOMER INFORMATION

dealer

address

city

state / province

zip / postal code

country

owner

address

city

state / province

zip / postal code

country

MACHINE IDENTIFICATION NUMBERS - RECORD

Machine Model Number _____

Machine Serial Number _____



HONDA ENGINE IDENTIFICATION NUMBERS - RECORD

Engine Model Number _____

Engine Serial Number _____

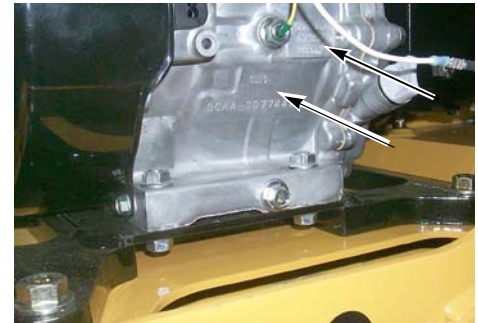

KOHLER ENGINE IDENTIFICATION NUMBERS - RECORD

Engine Model Number _____

Engine Serial Number _____



This page intentionally left blank.

Table of Contents

Receiving and Delivery Report	i	Avoid Battery Explosion	22-4
Dealer Prep	i	Avoid Battery Burns	22-5
Engine	ii	Jump-Starting Procedure	22-5
Hydraulics	ii		
Review of Operation	ii		
Dealer/Customer Information	iii		
Machine Identification Numbers - Record	iv		
Honda Engine Identification Numbers - Record	iv		
Kohler Engine Identification Numbers - Record	v		
		Shutdown Procedure	23-1
Safety Messages	10-1	Transporting the Machine	30-1
Safety Symbol Explanation	10-1	Driving the Machine	30-1
		Steering the Machine	30-3
		Trailing the Machine	30-3
		Loading	30-3
		Unloading	30-4
		Lifting	30-5
		Emergency Towing	30-6
Intended Use	15-1		
		Preparing Machine and Work Area	40-1
Controls	20-1	Operator Qualifications	40-1
Machine Controls (Honda and Kohler)	20-1	Personal Protection	40-2
Engine Controls - Honda	20-5	Sound and Vibration Levels	40-3
Engine Controls - Kohler	20-6	Operator Presence Switch - Check	40-4
		Prepare the Area	40-4
		Underground Utility Contact	40-5
		Look for Evidence of Underground Placement	40-6
		Striking a Utility	40-6
		Electricity	40-6
		Gas	40-7
		Fiber Optic	40-7
Starting Procedure	22-1		
Starting the Engine	22-1		
After Engine Starts	22-2		
Cold Weather Starting	22-3		
Engine	22-3		
Hydraulic Fluid	22-3		
Jump-Starting (Electric Start Option)	22-4		

Jobsite Assessment	40-8
Prepare the Machine	40-10
Operating the Trencher	50-1
Operate Safely	50-1
Trenching Tips	50-2
Trenching	50-3
Trench Cleaner Assembly/Restraint Bar	50-3
Trench - Start/Plunge Cut	50-3
Trench Cleaner - Adjust	50-5
Trench - Complete	50-5
Backfill Blade (Option)	55-1
Backfill Blade - Install/Remove	55-2
Backfill Blade Operation	55-5
Backfilling	55-5
Maintenance Intervals	60-1
Safety Signs	60-1
Maintenance Manual	60-2
Greasing the Machine	60-2
Hourmeter - Check for Maintenance Interval	60-2
Maintenance Intervals	60-3

Section 10: Safety Messages

General safety messages appear in this Safety Messages section. Specific safety messages are located in appropriate sections of the manual where a potential hazard may occur if the instructions or procedures are not followed.

A signal word “**DANGER**”, “**WARNING**”, or “**CAUTION**” is used with the safety alert symbol.

Safety signs with signal word “**DANGER**”, “**WARNING**”, or “**CAUTION**” are located near specific hazards.

DANGER Indicates a hazardous situation that, if not avoided, will result in death or serious injury.

WARNING Indicates a hazardous situation that, if not avoided, could result in death or serious injury.

CAUTION Indicates a hazardous situation that, if not avoided, could result in minor or moderate injury.

SAFETY SYMBOL EXPLANATION



This is the safety alert symbol. This symbol is used in combination with an exclamation mark or other symbols to alert you to the potential for bodily injury or death.

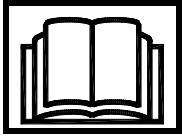

WARNING: Read Operator's Manual and safety signs before operating machine.

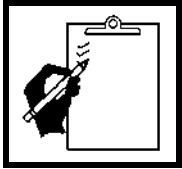

WARNING: Check machine before operating. Machine must be in good operating condition and all safety equipment installed and functioning properly.



WARNING: Wear personal protective equipment. Dress properly. Refer to "Personal Protection," [page 40-2](#).



WARNING: Keep spectators away.



WARNING: Engine exhaust can asphyxiate. Operate only outdoors.

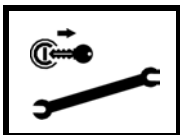

WARNING: Use Shutdown Procedure before servicing, cleaning, repairing or transporting machine. Refer to [Shutdown Procedure](#), page 23-1, for instructions.



WARNING: Pressurized fluid can penetrate body tissue and result in serious injury or death. Leaks can be invisible. Keep away from any suspected leak. Relieve pressure in the hydraulic system before searching for leaks, disconnecting hoses, or performing any other work on the system. If you must pressurize the system to find a suspected leak, use an object such as a piece of wood or cardboard rather than your hands. When loosening a fitting where some residual pressure may exist, slowly loosen the fitting until oil begins to leak. Wait for leaking to stop before disconnecting the fitting. Fluid injected under the skin must be removed immediately by a surgeon familiar with this type of injury.

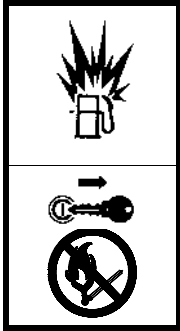

WARNING: Fuel and fumes can explode and burn.

Shut off engine before refueling. No flame. No smoking.



CAUTION: Hot muffler



WARNING: Failure to follow any of the preceding safety instructions or those that follow within this manual, could result in serious injury or death. This machine is to be used only for those purposes for which it was intended as explained in this Operator's Manual.

Section 15: Intended Use

The RTX100 is a self-propelled rubber tire or track machine intended to be used solely to produce an open trench in a continuous operation with rearward motion of the machine.

The RTX100 backfill blade attachment is intended to be used solely to push earthen material, typically to return excavated material back into the trench.

Always use the machine in accordance with the instructions contained in this manual, safety signs on the machine, and other material provided by Vermeer Corporation.

Proper maintenance and repair are essential for safety and efficient machine operation. Do not use the machine if it is not in suitable operating condition.

This page intentionally left blank.

Section 20: Controls

MACHINE CONTROLS (HONDA AND KOHLER)

(1) Off/On Switch (Recoil Start)

Push bottom of switch engine OFF



Push top of switch engine ON



(2) Keyswitch (Electric Start Option)

Counterclockwise engine and electrical system OFF



Vertical position electrical system ON



Clockwise from vertical position starts engine
Key returns to vertical position when released.

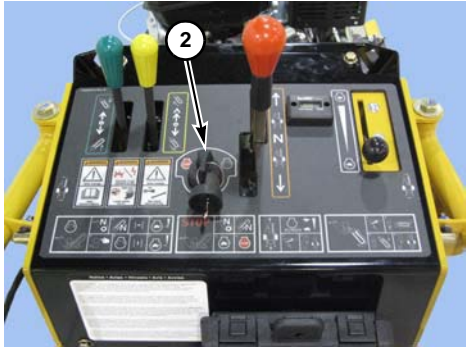

(3) **Hourmeter**

(4) **Throttle Lever**



Push forward..... increase engine RPM



Pull back decrease engine RPM

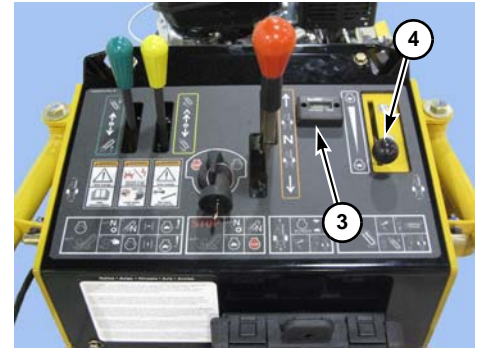

(5) Trencher Lift Lever (Green)



Push forward lower trencher boom



Pull back raise trencher boom

NOTE: Lever will spring return to NEUTRAL when released.

(6) Propel Lever (Orange)



Push forward variable speed forward

Center NEUTRAL



Pull back variable speed reverse

NOTE: Lever must be in NEUTRAL before engine will start.

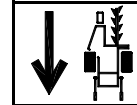
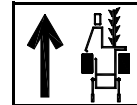

(7) Digging Chain Drive Lever (Yellow)



Push forward to detentengage digging chain

Center (NEUTRAL)stop digging chain



Pull backmomentarily reverse chain

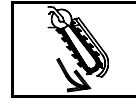

NOTE: Lever will spring return to NEUTRAL from reverse position.

NOTE: Lever must be in NEUTRAL before engine will start.

(8) Operator Presence Lever (left side)

Pull red lever under handlebar grip to allow engine to run when *Ground Drive Control* or *Digging Chain Drive Control* is engaged.

(9) Handlebars

Pivot handlebars to steer, rotating rear of machine in direction of push.

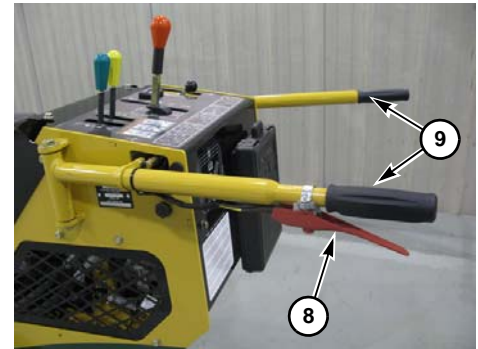
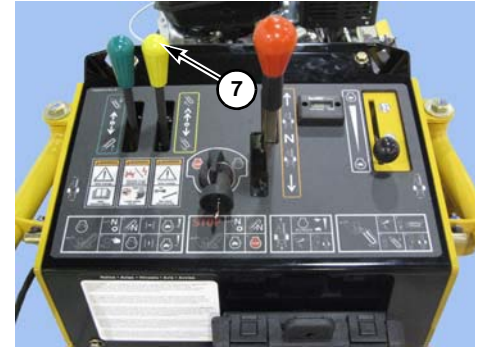
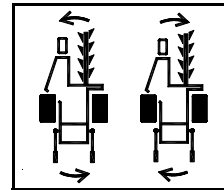

ENGINE CONTROLS - HONDA

(1) Choke Lever

Slide lever left when starting a cold engine. Gradually slide lever right after the engine starts and warms up.



(2) Fuel Shutoff Valve

Slide lever rightopen valve
Slide lever leftclose valve



(3) Rope Start

Pull rope to crank engine for starting. *Switch* on machine dash must be ON to start.

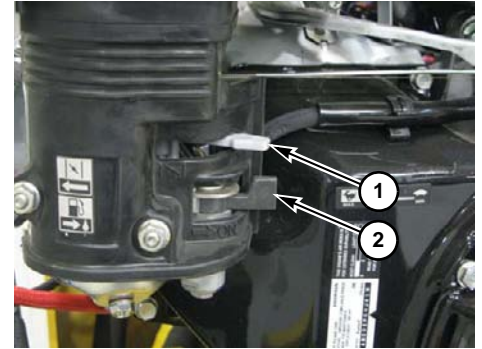

ENGINE CONTROLS - KOHLER

(1) Choke Lever

Slide lever left when starting a cold engine. Gradually slide lever right after the engine starts and warms up.



(2) Fuel Shutoff Valve

Slide lever right open valve

Slide lever left close valve



(3) Rope Start

Pull rope to crank engine for starting. *Switch* on machine dash must be ON to start.

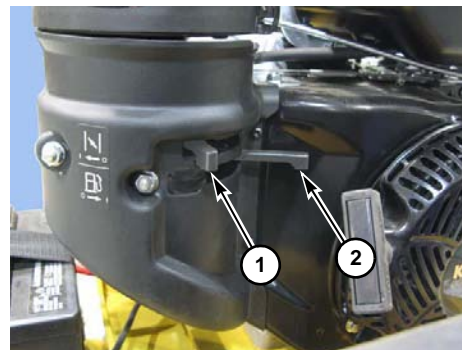

Section 22: Starting Procedure

STARTING THE ENGINE

Step 1: Place *Propel Lever* in NEUTRAL.

Step 2: Place *Digging Chain Drive Lever* in NEUTRAL.

Step 3: Fully close *Choke* (cold engine only).

NOTE: Open *Fuel Shutoff Valve* if necessary.

Step 4: Move *Throttle Lever* to 1/4 speed.

Step 5: Push *Off/On Switch* to ON position (recoil start).
Turn *Keyswitch* to ON position (electric start option).

Step 6: Start engine:

- Pull *Rope Start* to start machine (recoil start).
- Turn *Keyswitch* to START position to start machine (electric start option). Release switch when engine starts.

IMPORTANT: Do not crank engine continuously for more than 10 seconds at a time. If the engine does not start, allow a 60-second cool-down period between starting attempts. Failure to follow these guidelines can burn out the starter motor.

Step 7: After engine starts, gradually open *Choke*.

IMPORTANT: If engine fails to start in three attempts, turn switch OFF and check for fuel blockage or problems with ignition system.

Step 8: Reduce throttle to idle.

Do not operate engine under load until engine has warmed up.

For cold weather starting, refer to Engine Cold Weather Starting in this section.

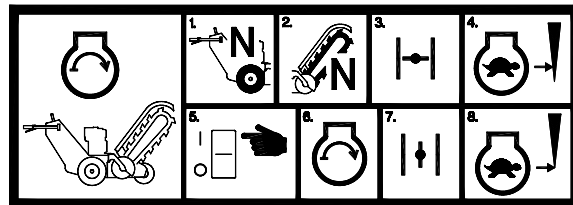

AFTER ENGINE STARTS

- Check operation of Operator Presence controls. The engine must stop if the *Operator Presence Lever* is released while the *Ground Drive Lever* or *Digging Chain Drive Lever* is engaged.

NOTE: This system is intended to help you operate the machine safely and must be maintained in good, functional condition.

- Check that machine does not move with *Propel Lever* in NEUTRAL.
- Check that trencher digging chain does not turn with *Digging Chain Drive Control* in NEUTRAL.

COLD WEATHER STARTING

Engine

Before operating in cold weather, refer to the Engine Operation Manual for recommended engine oil, fuel, and starting procedures.

Hydraulic Fluid

Refer to “Lubricants,” Specifications section in the [Maintenance Manual](#) for recommended hydraulic fluids.

When using ISO 100 hydraulic fluid below +23°F (-5°C):

- Warm up engine.
- Gradually increase engine RPM, and allow hydraulic oil to warm up for 30 minutes.

NOTE: Reduce engine speed if hydraulic pump whines. Pump noise may indicate lack of oil which can damage the pump.

IMPORTANT: Do not spray starting fluid into the air cleaner. Engine damage can result.

JUMP-STARTING (ELECTRIC START OPTION)

Avoid Battery Explosion

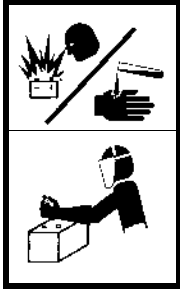

WARNING: Battery fumes are flammable and can explode. Keep all burning materials away from battery. Battery explosion can blind. Acid can blind and burn. Tools and cable clamps can make sparks.

Do not smoke. Shield eyes and face. Read instructions.

Do not jump-start or charge a battery that is frozen or low on electrolyte.

Avoid explosion hazard. If equipped with battery caps, they must be in place and tight.

IMPORTANT: Use only a 12-volt system for jump-starting. Do not allow vehicle used to jump-start to be in contact with the disabled machine. Vehicles in contact have a ground connection which allows a spark to occur at the battery when the positive jumper cable is connected or removed. If equipped with battery caps, they must be in place and tight to reduce risk of battery explosion.

Avoid Battery Burns

Battery contains sulfuric acid which can cause severe burns. Avoid contact with eyes, skin, and clothing.

In case of acid contact:

External: Flush with plenty of water. If eyes have been exposed, flush with water for 15 minutes and get prompt medical attention.

Internal: Drink large quantities of water or milk, follow with milk of magnesia, beaten egg, or vegetable oil. Call a physician immediately.

Jump-Starting Procedure

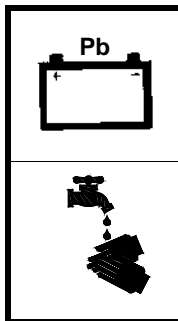

WARNING: Battery post, terminals, and related accessories contain lead and lead compounds, chemicals known to the state of California to cause cancer and reproductive harm.

Wash hands after handling.

Step 1: Turn *Keyswitch* to OFF and remove battery access cover.

Step 2: Connect jumper cables in the following order:

- a. Red to discharged battery POSITIVE (+) terminal **(1)**.
- b. Red to boost battery POSITIVE (+) terminal **(2)**.
- c. Black to boost battery NEGATIVE (-) terminal **(3)**.
- d. Black to frame **(4)** of machine with the discharged battery. Make connection away from battery.

NOTE: To avoid sparks near battery, disconnect black jumper cable at point **(4)** before adjusting red cable at point **(1)**.

Step 3: Start engine.

Step 4: Remove cables in REVERSE order and install covers over cable clamps. Install battery access cover.

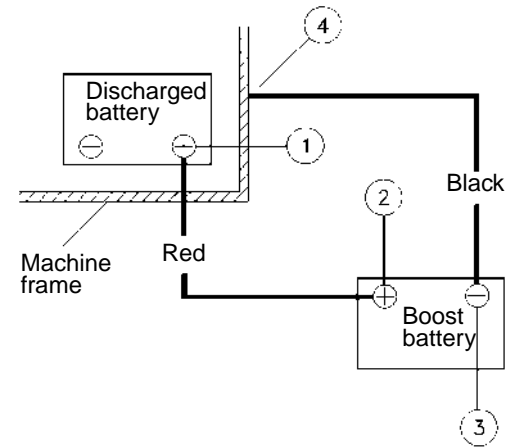

Section 23: Shutdown Procedure

IMPORTANT: For your safety and the safety of others, use shutdown procedure before working on the machine for any reason, including servicing, cleaning, or inspecting the machine.

A variation of this procedure may be used if so instructed within this manual or if an emergency requires it.

- Step 1:** Place *Propel Lever* in NEUTRAL.
- Step 2:** Place *Digging Chain Drive Lever* in NEUTRAL.
- Step 3:** Reduce engine speed to idle.
- Step 4:** Push *Off/On Switch* to OFF to shut off engine (recoil start).
Turn *Keyswitch* to OFF and remove key (electric start option).
- Step 5:** Shut off fuel valve to prevent flooding of the carburetor.

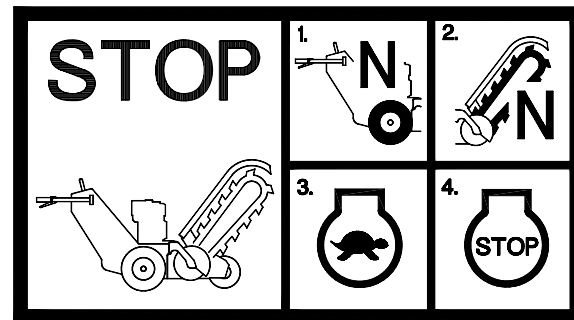

NOTE: If shutting down on a slope, turn machine to face across the slope to prevent machine from creeping away from the parked position. If this is not possible on the track version due to lack of engine power, install pin (1) on left side track to engage sprocket. If pin does not go all the way through, push the unit forward or backward slightly until pin will fully engage. Remove pin and place in bracket vertically (2) before moving machine.

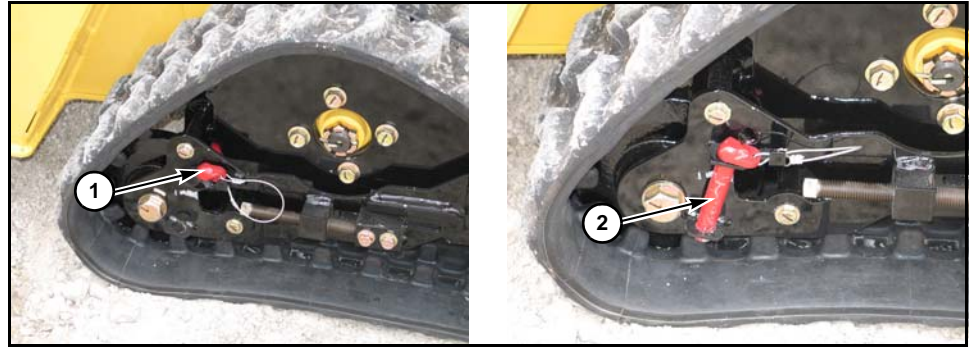

Section 30: Transporting the Machine

DRIVING THE MACHINE



WARNING: Rollover can crush.

Do not allow anyone to ride on machine.



WARNING: Runover can crush.

Keep feet away from wheels or tracks.

Step 1: Follow *Starting Procedure, page 22-1*.

Step 2: Increase engine RPM.

Step 3: Fully raise trencher boom.

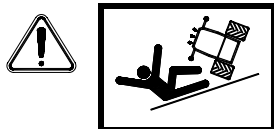

WARNING: Rollover can crush. Avoid situations where rollover can occur.

Step 4: Set throttle to desired engine speed (1).

Step 5: Pull up red *Operator Presence Lever (2)* on left handle.

NOTE: Machine will shut off if *Propel Lever* or steering controls are moved out of NEUTRAL if the *Operator Presence Lever* is not engaged.

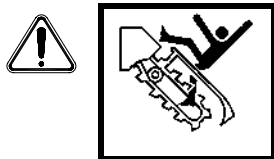

DANGER: Never move machine with digging chain engaged. Contact with moving digging chain will result in death or serious injury.

Step 6: Use *Propel Lever (3)* to move machine.

IMPORTANT: Until the operator has become familiar with the controls and understands the capability of the machine, use a slower ground speed to move machine.

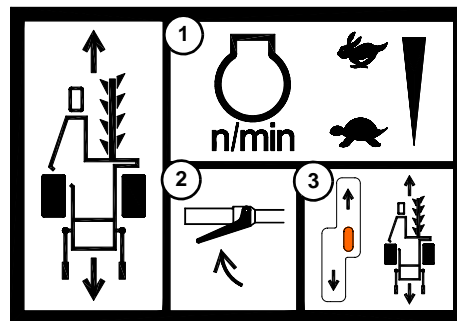

Steering the Machine

Pivot handlebars to steer, rotating rear of machine in direction of push. Machine will counterrotate if *Propel Lever* is in NEUTRAL.

TRAILERING THE MACHINE

Loading

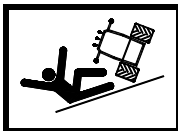

WARNING: Machine may slide down loading ramps or off trailer deck. Serious injury or death may result. Do not load onto slick trailer surface.

Step 1: Ensure gross weight of machine with attachments is within the gross weight limits of the trailer and the towing vehicle. Load machine on a level surface with trailer attached to towing vehicle. Use caution when going up or down trailer ramps.

NOTE: Trencher weights are included in the Specifications Section of the [Maintenance Manual](#). These weights can be used to determine the approximate gross weight of a vehicle configuration.

Step 2: Follow [Starting Procedure, page 22-1](#).

Step 3: Position machine in-line with the trailer ramps.

Step 4: Set throttle to half speed. Use *Propel Lever* to move machine.

Step 5: Drive machine squarely onto trailer.

Step 6: Stop machine when tie-down position is reached. The tie-down position distributes weight on the trailer as recommended by the trailer manufacturer.

Step 7: Shut off engine.

Step 8: Turn fuel shutoff to OFF.

NOTE: If fuel is not shut off while trailering, air turbulence around engine can draw fuel into carburetor and cause engine flooding. In extreme cases, fuel can get into engine crankcase oil, which can cause engine wear or damage.

Step 9: Fasten machine to the trailer using one front (1) and two rear (2) tie-down points.

Unloading

Step 1: To unload machine, place trailer on a level surface.

Step 2: Remove chains.

Step 3: Open fuel shutoff valve.

Step 4: Follow *Starting Procedure, page 22-1*.

Step 5: Set *Throttle* to half speed.

Step 6: Use *Propel Lever* to move machine off the trailer.

NOTE: Hook (3) is intended for use with Vermeer TLR series trailers.

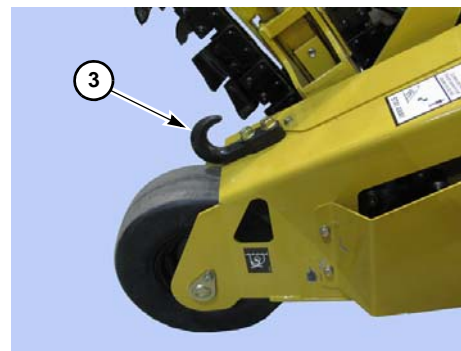
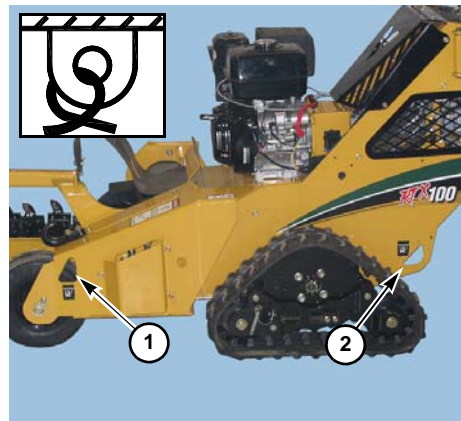

Lifting



WARNING: Never lift machine over personnel. The load may fall or shift, crushing anyone beneath it.

- Step 1:** Follow [Shutdown Procedure, page 23-1](#).
- Step 2:** Attach lifting chains or straps to front **(1)** and both rear **(2)** tie-down points. Ensure machine weight is evenly distributed.
- NOTE:** Minimum required working load limit per sling leg is 1000 lb (450 kg). Minimum sling leg length is 6 ft (2 m).
- Step 3:** Use suitable equipment to lift and lower machine onto the transport vehicle.
- Step 4:** Fasten machine to transport vehicle using tie-downs.

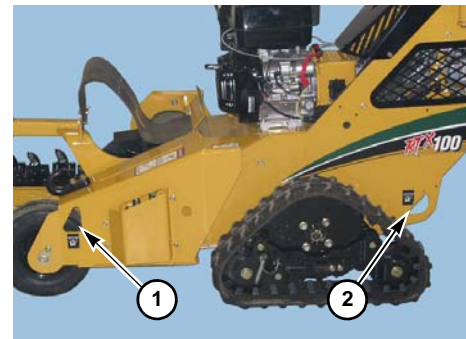

Emergency Towing

The machine can be towed slowly a short distance by opening the bypass valves (3), allowing hydraulic fluid to bypass the pump.

NOTE: Chock wheels/tracks to prevent machine from moving when opening bypass valves with machine on a slope.

Step 1: Remove four bolts (1). Pull out screen (2).

Step 2: Turn valves (3) on pumps counterclockwise two revolutions. Each valve has a 1/8" (3 mm) hole so that a metal rod can be used to turn it.

Step 3: Attach appropriately sized tow chain to front or rear tie-down points (4), and tow machine to transport vehicle.

NOTE: Do not exceed 1–2 mph (2–3 km/h) when towing.

Step 4: After towing, tighten tow valves (3); torque to 9–10 ft-lb (12.2–13.6 Nm).

Step 5: Install left side cover (2) and bolts (1) before placing machine back into service.

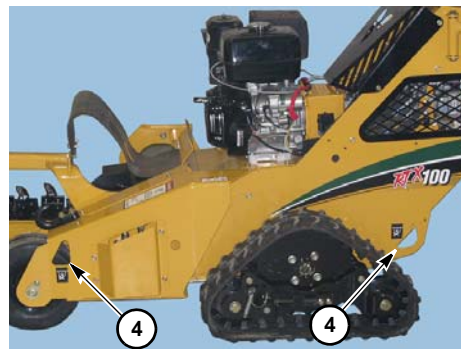
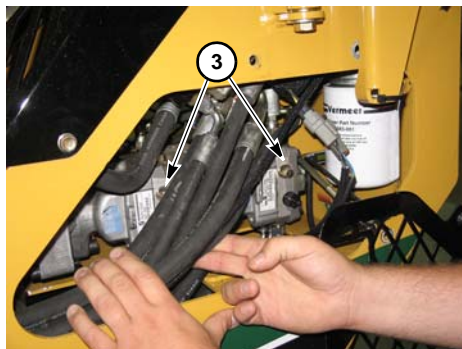
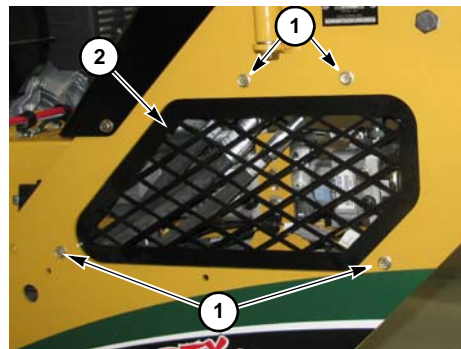

Section 40: Preparing Machine and Work Area

OPERATOR QUALIFICATIONS

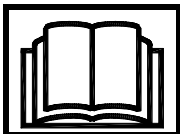

WARNING: Read Operator's Manual and safety signs before operating machine.

Allow only responsible, properly instructed individuals to operate machine.

Become familiar with the controls, operation and use of the machine under the supervision of a trained and experienced operator.

The operator must be familiar with the workplace's safety rules and regulations, and must be mentally and physically capable of operating the machine safely.

PERSONAL PROTECTION



WARNING: Wear personal protective equipment. Wear close-fitting clothing and confine long hair. Avoid jewelry, such as rings, wristwatches, necklaces, or bracelets.

Operating the machine will require you to wear protective equipment. You should always wear a hard hat, safety shoes, hearing protectors, and eye protection. If working near traffic, wear reflective clothing.

Hearing protection is recommended when operating the machine. Hearing protection devices provide differing levels of sound reduction. It is important to select a device that is adequate and appropriate for your specific work environment. Actual sound levels may vary widely, depending on your working conditions. To determine the level of hearing protection your work environment requires, enlist the help of your local environmental noise specialist.

Eye protection must consist of wraparound safety glasses or goggles.

Other workers in the immediate area must also wear hard hats, hearing, and eye protection.

Wear close-fitting clothing and confine long hair.

Avoid wearing jewelry, such as rings, wristwatches, necklaces, or bracelets.

SOUND AND VIBRATION LEVELS

Sound pressure and sound power levels were determined according to test procedures specified in ISO 3744 and ISO 6394.

Equivalent Continuous A-Weighted Sound Pressure

at Operator's Ear Honda: 91 dB(A)

..... Kohler: * dB(A)

Guaranteed Sound Power Level as determined by EU Directive 2000/14/EC Honda: 108 dB(A)

..... Kohler: * dB(A)

Hand/arm vibration exposure has been measured according to test procedures specified in ISO 5349.

Hand/arm vibration, track option 7.01 m/s²

Hand/arm vibration, tire option. 4.79 m/s²

NOTE: The stated sound levels are representative for a given operating condition. Operating conditions may vary at each jobsite. The actual sound levels for your application and operating conditions may be different.

*Information not available at time of printing.



OPERATOR PRESENCE SWITCH - CHECK

The Operator Presence system uses one red lever below the left handlebar to detect the presence of an operator. The operator must pull up this lever for the ground drive or attachment drive to be operated.

If the operator releases the lever while the ground drive or attachment drive is engaged, the engine will stop. The ground drive and attachment drive controls must be returned to NEUTRAL before restarting the engine.

The Operator Presence system is intended for your safety and must be maintained in good functional condition. Contact your Vermeer dealer if it does not function properly.

PREPARE THE AREA

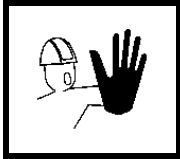

WARNING: Keep spectators away.

UNDERGROUND UTILITY CONTACT

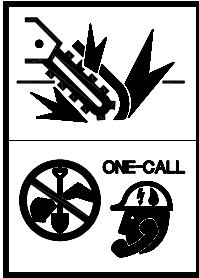

WARNING: Electricity or gas explosion can kill. Laser light in cut cable can cause eye damage.

Locate utilities before trenching. Call 811 or 1-888-258-0808 (U.S. or Canada) or local utility companies or national regulating authority.

Before you start any digging project, do not forget to call the local One-Call system in your area and any utility company that does not subscribe to the One-Call system. For areas not represented by One-Call Systems International, contact the appropriate utility companies or national regulating authority to locate and mark the underground installations. If you do not call, you may have an accident or suffer injuries; cause interruption of services; damage the environment; or, experience job delays.

The One-Call representative will notify participating utility companies of your proposed digging activities. Utilities will then mark their underground facilities by using the following international marking codes:

Red	Electric	Green/Brown	Sewer
Yellow	Gas, Oil or Petroleum	White	Proposed Excavation
Orange	Communication, Telephone, TV	Pink	Surveying
Blue	Potable Water		

OSHA CFR 29 1926.651 requires that the estimated location of underground utilities be determined before beginning the excavation or underground drilling operation. When the actual excavation or bore approaches an estimated utility location, the exact location of the underground installation must be determined by a safe, acceptable and dependable method. If the utility cannot be precisely located, it must be shut off by the utility company.

Look for Evidence of Underground Placement

Visually check for:

- notices of underground placements
- manhole covers
- drop boxes
- recent trenching activity

Striking a Utility

Electricity

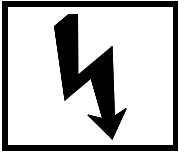

DANGER: Electric shock can kill. If strike occurs, stay on machine. Have someone who is clear of the area contact the utility company to shut off electrical power. Do not allow anyone to approach the machine.

Some circuit breakers automatically reset. Do not assume power has been permanently disconnected until you confirm that the utility company has locked out power to that line.

Gas

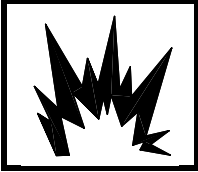

DANGER: Gas explosion can kill.

If you strike a gas line, shut off engine and evacuate area immediately. Contact utility company and do not return until the utility company gives permission to do so.

If you strike a gas line, shut off engine and evacuate area immediately. Contact utility company and do not return until the utility company gives permission to do so.

Fiber Optic

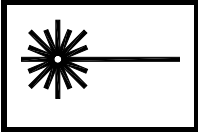

WARNING: Laser light may damage eyes. Do not look into the end. Fiber optic cables carry laser light which may damage your eyes. If you are not sure what kind of cable it is, do not look into the end. Contact appropriate utility company for assistance.

Do not look into the end. Fiber optic cables carry laser light which may damage your eyes.
If you are not sure what kind of cable it is, do not look into the end.
Contact appropriate utility company for assistance.

Jobsite Assessment

Examine work area for any obstructions, conditions, or situations which may impair machine operation or create a safety hazard for the operator or other persons. Use information in this manual combined with your own good judgment when identifying these hazards and implementing hazard avoidance measures.

The operator or job foreman should inspect jobsite for:

- notices of underground placements
- manhole covers
- drop boxes
- recent trenching activity
- any evidence of possible underground placements
- banks, overhangs, drop-offs, and trenches

When work is planned inside or around structures such as buildings, bridges, and low-hanging tree limbs, check for adequate overhead and side clearances.



WARNING: Engine exhaust can asphyxiate. If inhaled directly or continuously, the combustion fumes produced by the engine can be very dangerous and/or lethal for the human body. If work has to be done in enclosed environments, take all necessary precautions to ensure the circulation of fresh air and protect the respiratory tract using a suitable mask.

Good ventilation is very important. Sparks from the electrical system and engine exhaust can cause an explosion or fire in a flammable or explosive atmosphere. Do not operate this machine in an area with flammable dust or vapors.

Carbon monoxide fumes from the engine can asphyxiate. Operate only outdoors or provide adequate ventilation if indoor operation is essential.

PREPARE THE MACHINE



WARNING: Check machine before operating. Machine must be in good operating condition and all safety equipment installed and functioning properly.

- Ensure you understand and comply with all jobsite rules that might apply to your work situation.
- If operating along a road, properly warn and divert motor and pedestrian traffic. Use all necessary signs, cones, flag persons, or lighting devices needed for the work situation.

IMPORTANT: Machine controls and electrical/electronic devices are not rated to withstand high pressure water and temperature power washers. Water intrusion will likely cause malfunction or damage to any devices hit directly by the water spray. Keep pressure washer stream away from machine controls and electrical/electronic devices. Compressed air can also push moisture through some connector and component seals. Do not point air nozzle directly at seal areas.

Section 50: Operating the Trencher

OPERATE SAFELY

Operate only from operator's control area.

The machine is equipped with an Operator Presence system. This system is intended for your safety and must be maintained in good functional condition. The engine must stop if the *Operator Presence Lever* is released while the *Propel Lever* or *Digging Chain Drive Lever* is engaged. Starting the ground drive or digging chain drive without engaging the *Operator Presence Lever* must also stop the engine. Contact your authorized independent Vermeer dealer if system requires repair or adjustment.

Ensure you are familiar with the location and function of each control before operating the machine. Refer to "Controls," [page 20-1](#).

Survey the area for obstacles or persons before operating.

TRENCHING TIPS

For optimum trenching performance:

- Keep trencher chain adjusted properly.
- For small loose rock or dirt, use cup cutters.
- Ensure cutters are in good condition.
- Rock and frost cutting normally require rotary cutters.
- Some digging conditions, such as mixed aggregate rock that fractures easily and crumbles, may go better with a combination cup cutter and rotary cutter setup.
- Contact your Vermeer dealer for optimal chain setup in your area.
- Do not overload engine while trenching.
- Refer to the [Maintenance Manual](#) for instructions on adjusting chain and replacing/removing cutters.

NOTE: If equipped with backfill blade, remove blade before trenching. Refer to “Backfill Blade - Install/Remove,” [page 55-2](#).

TRENCHING

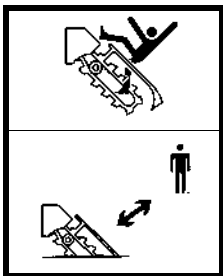

DANGER: Moving digging chain can kill or cut off arm or leg. Trench cave-in may cause you to fall onto moving chain.

Stay away from moving digging chain.

Trench Cleaner Assembly/Restraint Bar

The trench cleaner assembly or restraint bar is intended to help protect against accidental personal contact with the digging chain. The trench cleaner assembly or restraint bar must be in place while digging. Refer to the [Maintenance Manual](#) for adjustment instructions.

Trench - Start/Plunge Cut

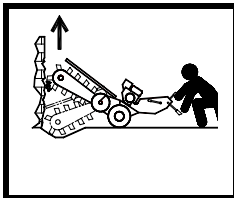

WARNING: The digging chain can suddenly drag the machine forward if the trencher is forced too quickly into the ground or catches on an object. Stay away from houses, fences, trees, and other objects. Digging chain contact with fences, trees, or walls can cause chain to climb upward quickly and turn machine over rearward. Serious injury or death can result if struck by machine.

Step 1: Line up machine at beginning of trench.

Step 2: If equipped with trench cleaner, follow [Shutdown Procedure](#), page 23-1. If not so equipped, proceed to Step 5.

Step 3: Raise trench cleaner (1), engage latch (2), and secure with linch pin (3).

Step 4: Follow *Starting Procedure*, page 22-1.

Step 5: Pull up on red *Operator Presence Lever* (4).

Step 6: Engage digging chain (5) and move *Throttle* to full RPM.

Step 7: Lower trencher boom slowly to the desired digging depth (6).

NOTE: Lowering boom too quickly will result in excessive boom and machine bounce. A small amount of rearward ground travel during the plunge cut may help in reducing boom and machine bounce.

IMPORTANT: Do not attempt to force boom down faster than digging chain can remove material. Do not overload engine. If the engine RPM drops or the digging chain slows down, raise boom until speed increases, then continue lowering the boom. Move machine rearward slightly when making plunge cut to avoid damaging restraint bar or trench cleaner.

Step 8: Use *Propel Lever* (7) to move machine slowly towards the operator.

Step 9: If using a trench cleaner, follow “Trench Cleaner - Adjust,” page 50-5, instructions.

Step 10: Adjust ground speed for the best productivity when the required trench depth has been reached.

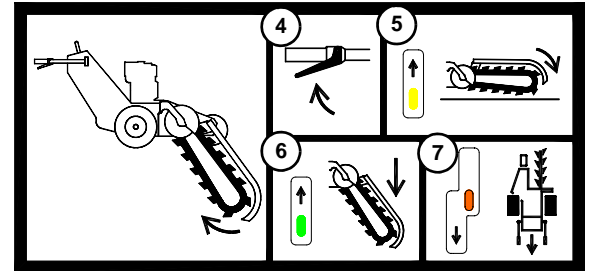
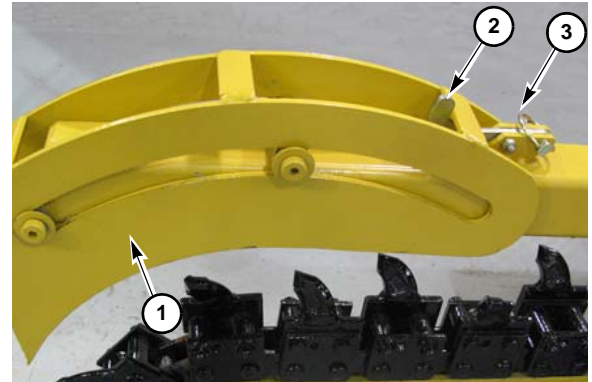

Trench Cleaner - Adjust



WARNING: Contact with a moving digging chain will result in serious injury or death.
Never adjust trench cleaner assembly with the digging chain or engine running.

- Step 1: After making plunge cut, raise trencher out of ground until boom is level with ground.
- Step 2: Stop digging chain and shut off engine.
- Step 3: Remove lynch pin (1) to release latch (2). Lower trench cleaner (3). Reinstall lynch pin (1) in storage position.

Trench - Complete

- Step 1: Return *Propel Lever* to NEUTRAL to stop machine travel.
- Step 2: Raise trencher slowly. When the chain is out of the ground, move *Digging Chain Drive Lever* to NEUTRAL.
- Step 3: Reduce engine speed to idle.

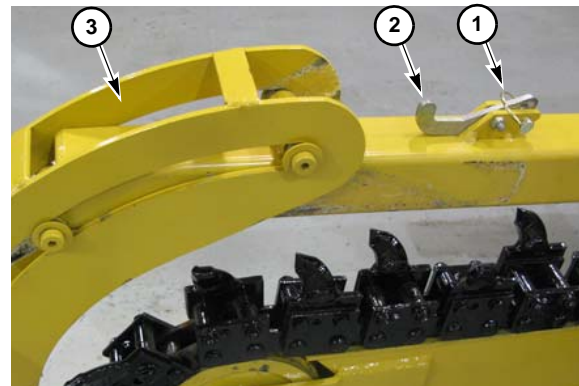

This page intentionally left blank.

Section 55: Backfill Blade (Option)

The backfill blade is intended for machines on which Backfill Blade Spacer Assembly 296312896 has been installed. Installation instructions are included with spacer assemblies purchased from Vermeer Parts Center.

The backfill blade is not intended for machines that do not have this assembly installed.

The block supplied with this kit is $3/8''$ (1 cm) thicker and $1.75''$ (4.4 cm) longer than the factory installed block. This larger block is required for proper backfill blade support.



Standard block installed at factory

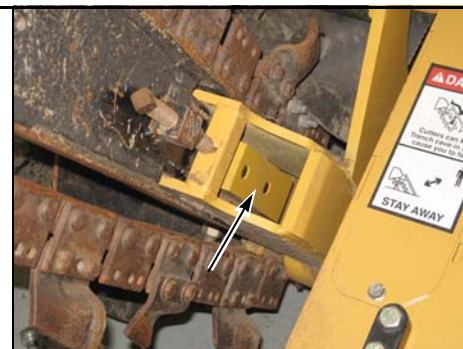

Optional backfill blade spacer assembly

BACKFILL BLADE - INSTALL/REMOVE

Remove backfill blade before trenching; install it to backfill.

Step 1: Move *Propel Lever* to NEUTRAL.

Step 2: Move *Trencher Digging Chain* to STOP.

Step 3: Raise trencher boom.

Step 4: Reduce engine speed to IDLE.

Step 5: Shut off engine.

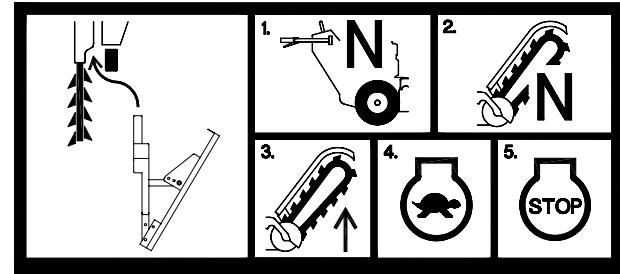

Step 6: Remove adjustment pin from storage position (1) and swing blade angle adjustment arm out from blade.

Step 7: Insert pin into one of three holes (2) depending on desired working width.

IMPORTANT: When changing angle after blade is installed on machine, raise blade enough to remove contact with the ground before adjustment.

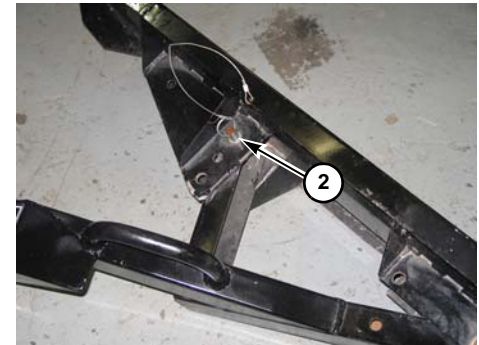
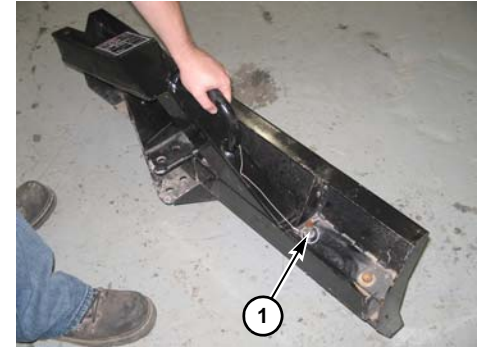
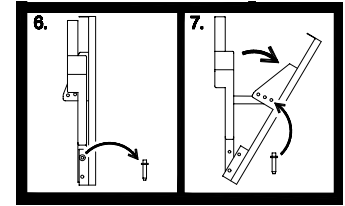

Step 8: Insert blade arm (3) into pocket (4) on machine.

Step 9: Pull and turn locking pin (5) to secure blade arm to machine.

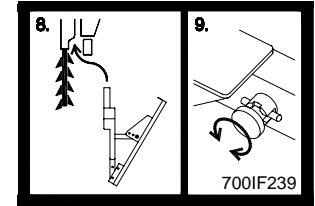

To remove blade:

Step 1: Follow Steps 1–5 under “Backfill Blade - Install/Remove,” [page 55-2](#).

Step 2: Pull and turn pin (5) to release blade.

Step 3: Slide blade out of pocket.

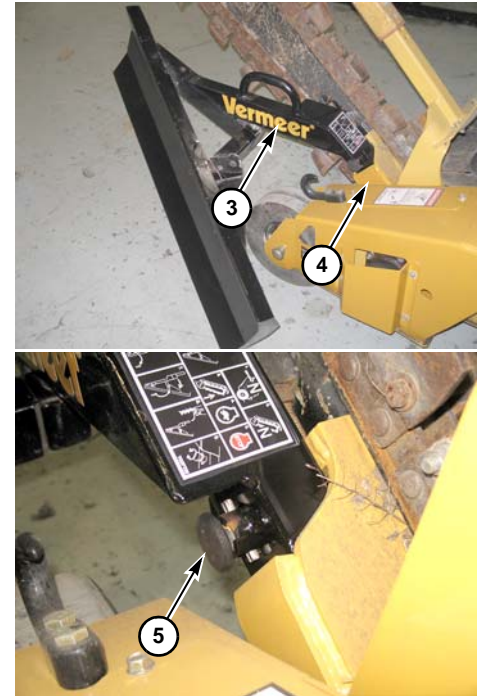

BACKFILL BLADE OPERATION



WARNING: Before attempting to operate machine, refer again to “Safety Messages,” [page 10-1](#), for important information.

Familiarize yourself with location and function of the tractor controls and the backfill blade controls before operating. Refer to “Controls,” [page 20-1](#).

Use *Trencher Lift Lever* (1) to raise or lower blade.



Backfilling

Step 1: Use *Propel Lever* to move machine for backfilling.

Step 2: When moving spoil into trench, do not fill blade to full capacity. Make more than one pass at spoil pile. This will result in a better backfilling job.

NOTE: If engine begins to stall while pushing spoil, reduce amount of spoil being pushed by raising blade or moving more to outside of spoil pile, or by adjusting backfill blade angle. Refer to “Backfill Blade - Install/Remove,” [page 55-2](#).

Step 3: Once trench is completely backfilled, drive with one track or set of tires on trench to compact soil.

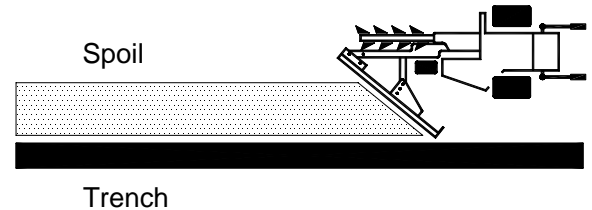

This page intentionally left blank.

Section 60: Maintenance Intervals

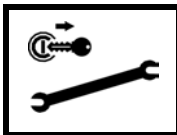

WARNING: Use Shutdown Procedure before servicing, cleaning, repairing or transporting machine. Refer to [Shutdown Procedure, page 23-1](#), for instructions.

Visually inspect machine daily before starting the machine.

Make no modifications to your equipment unless specifically recommended or requested by Vermeer Corporation.

SAFETY SIGNS

Safety signs located on your machine contain important and useful information that will help you operate your equipment safely. Refer to the [Parts Manual](#) and “Controls,” [page 20-1](#) for locations.

To assure that all safety signs remain in place and in good condition, follow the instructions given below:

- Keep safety signs clean. Use soap and water - not mineral spirits, abrasive cleaners, or other similar cleaners that will damage the sign.
- Replace any damaged or missing safety signs. When attaching signs, the temperature of the mounting surface must be at least 40°F (5°C). The mounting surface must also be clean and dry.
- When replacing a machine component with a safety sign attached, replace the safety sign also.
- Replacement safety signs can be purchased from your Vermeer equipment dealer.

MAINTENANCE MANUAL

Maintenance intervals are included for reference only. Before performing any maintenance, refer to the [Maintenance Manual](#) for safety guidelines and correct procedures.

Refer to the Engine Operation Manual for additional information and service requirements. Shorten maintenance intervals when operating under dusty, dirty conditions.

GREASING THE MACHINE

As a general rule, grease machine after it is shut down for the day. This protects the metal under the seals from corrosion caused by condensation as the temperature drops.

Ensure all fittings and grease applicator nozzle are clean before applying the grease. If any grease fittings are missing, replace them immediately.

HOURLY METER - CHECK FOR MAINTENANCE INTERVAL

The hourmeter (1) is used to determine maintenance intervals for the machine.

Maintenance intervals are based on normal operating conditions. When operating under severe conditions, the maintenance intervals should be shortened.

When a preprogrammed maintenance interval has been reached, the display will flash the service to be performed. For example, at the first 20 service hours, display will flash “oil change”. To reset display, place tip of included wand (2) against dot (3). In several seconds the display will stop flashing.

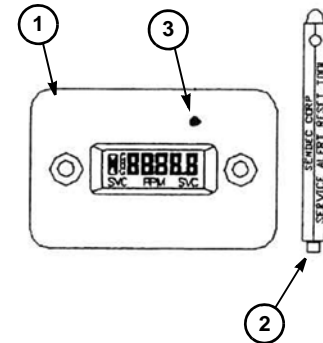

MAINTENANCE INTERVALS

Initial = Initial maintenance on new machine. Regular maintenance interval may be different.

● = Regular maintenance interval.

For Vermeer maintenance replacement part numbers, refer to the [Parts Manual](#) or call your Vermeer dealer.

Service	Maintenance Interval - Service Hours										
	5 or Twice Daily	10 or Each Use	20 or 1 Month	50	100	200	250	300	500	As Required	
Outboard Bearing - Grease	●										
End Idler (Greaseable Option) - Grease	●										
Air Intake and Cooling Areas (Kohler) - Check/Clean		●									
Muffler Screen (Kohler) - Check		●									
Engine Oil Level - Check		●									
Air Cleaner Element - Check		●									
Fuel Tank - Fill		●									
Fuel Tank Filter (Kohler) - Clean		●									
Hydraulic Fluid Level - Check		●									
Undercarriage - Inspect		●									
Track Tension - Check		●									
Track Condition - Check		●									
Trencher End Idler Side Play - Check		●									
Engine Oil (Honda) - Change			Initial								
Air Cleaner Element - Clean				●							
Nose Wheel Bearing - Grease				●							

Service	Maintenance Interval - Service Hours									
	5 or Twice Daily	10 or Each Use	20 or 1 Month	50	100	200	250	300	500	As Required
Control Levers Linkage - Oil				●						
Hydraulic Filter - Replace				Initial						
Track Tension - Adjust				Initial						
Spark Plug - Check/Adjust					●					
Spark Arrester (Honda) - Clean					●					
Fuel Sediment Cup - Clean					●					
Fuel Tank and Filter (Honda) - Clean					●					
Cooling Areas (Kohler) - Clean					●					
Muffler Screen (Kohler) - Clean					●					
Engine Oil - Change					●					
Control Levers - Check					●					
Trencher Components - Check					●					
Digging Chain - Check					●					
Tires and Rims - Check					●					
Machine - Overall Check					●					
Operator Presence System - Check					●					
Hydraulic System - Check					●					
Neutral Start Interlocks - Check					●					
Safety Signs Maintenance					●					
Fuel Filter (Kohler) - Replace						●				
Valve Clearance (Kohler) - Check/Adjust						●				
Starter Motor Drive (Kohler - if equipped) - Service						●				
Combustion Chamber (Kohler) - Decarbonize						●				

Service	Maintenance Interval - Service Hours									
	5 or Twice Daily	10 or Each Use	20 or 1 Month	50	100	200	250	300	500	As Required
Air Cleaner Element (Kohler) - Replace						●				
Hydraulic Filter - Replace							●			
Spark Plug (Honda) - Replace								●		
Idle Speed (Honda) - Check/Adjust								●		
Valve Clearance (Honda) - Check/Adjust								●		
Air Cleaner Element (Honda) - Replace								●		
Hydraulic Fluid - Change									●	
Battery Electrolyte Levels and Terminals - Check/Clean (Electric Start Option)									●	
Engine System - Check										●
Battery - Replace (Electric Start Option)										●
Digging Chain - Maintain										●
Digging Chain Drive Sprocket - Replace										●
Digging Chain - Adjust										●
Digging Chain - Remove/Install										●
Digging Chain Wear - Check										●
Cutters - Replace										●
Trench Cleaner/Restraint Bar - Adjust										●
Track Tension - Adjust										●
Tracks - Replace										●

This page intentionally left blank.

Index

A

After Engine Starts, 22-2
Avoid Battery Burns, 22-5
Avoid Battery Explosion, 22-4

B

Backfill Blade - Install/Remove, 55-2
Backfill Blade (Option), 55-1
Backfill Blade Operation, 55-5
Backfilling, 55-5

C

Cold Weather Starting, 22-3
Controls, 20-1

D

Dealer Prep, i
Dealer/Customer Information, iii
Driving the Machine, 30-1

E

Electricity, 40-6
Emergency Towing, 30-6
Engine Controls - Honda, 20-5
Engine Controls - Kohler, 20-6
Engine, 22-3

F

Fiber Optic, 40-7

G

Gas, 40-7
Greasing the Machine, 60-2

H

Honda Engine Identification Numbers - Record, iv
Hourmeter - Check for Maintenance Interval, 60-2
Hydraulic Fluid, 22-3

I

Intended Use, 15-1

J

Jobsite Assessment, 40-8
Jump-Starting (Electric Start Option), 22-4
Jump-Starting Procedure, 22-5

K

Kohler Engine Identification Numbers - Record, v

L

Lifting, 30-5
Loading, 30-3
Look for Evidence of Underground Placement, 40-6

M

Machine Controls (Honda and Kohler), 20-1
Machine Identification Numbers - Record, iv
Maintenance Intervals, 60-1, 60-3
Maintenance Manual, 60-2

N

O

Operate Safely, 50-1
Operating the Trencher, 50-1
Operator Presence Switch - Check, 40-4
Operator Qualifications, 40-1

P

Personal Protection, 40-2
Prepare the Area, 40-4
Prepare the Machine, 40-10
Preparing Machine and Work Area, 40-1

Q

R

Receiving and Delivery Report, i

S

Safety Messages, 10-1
Safety Signs, 60-1
Safety Symbol Explanation, 10-1
Shutdown Procedure, 23-1
Sound and Vibration Levels, 40-3
Starting Procedure, 22-1
Starting the Engine, 22-1

Steering the Machine, 30-3

Striking a Utility, 40-6

T

Trailing the Machine, 30-3
Transporting the Machine, 30-1
Trench - Complete, 50-5
Trench - Start/Plunge Cut, 50-3
Trench Cleaner - Adjust, 50-5
Trench Cleaner Assembly/Restraint Bar, 50-3
Trenching Tips, 50-2
Trenching, 50-3

U

Underground Utility Contact, 40-5
Unloading, 30-4

Revision History

Revision	Date	Pages	Description
to1_00	09/08	All	Temporary Operator's Manual released
o1_00	01/09	All	First edition production manual released
o1_01	06/09	All	Updated safety definitions; corrected graphics; added startup, shutdown, transporting graphics; sound and vibration levels added; operating and maintenance decals added; maintenance interval updated
o1_02	10/09	Sections: 40, 50, 55	Machine wash; backfill blade option added
o2_00	12/10	All	Updated Honda engine, miscellaneous updates, Kohler engine not currently available
o2_01	04/11	All	Added Kohler engine option and electric start <i>Keyswitch</i> , miscellaneous updates
o2_02	02/12	Section 20	Update recoil start switch and control panel decal



WARNING

The engine exhaust from this product contains chemicals known to the State of California to cause cancer, birth defects, or other reproductive harm.

**Copyright 2010–2012. All rights reserved.
Vermeer Corporation
1210 Vermeer Road East, P.O. Box 200
Pella, Iowa 50219-0200**