

RTX200 trencher

Operator's manual

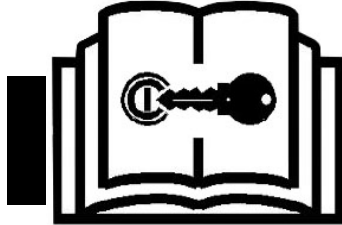

EN_o1_04_original instructions
Publication date: 2022_11_16
Serial no. 101-
Order no. 105400DY4
Cabled assembly no. 163743448



Vermeer[®]

EQUIPPED TO
DO MORE.[®]

Introduction

This manual explains the proper operation of your machine. Study and understand these instructions thoroughly before operating or maintaining the machine. Failure to do so could result in personal injury or equipment damage. Consult your Vermeer dealer if you do not understand the instructions in this manual or need additional information.

The instructions, illustrations and specifications in this manual are based on the latest information available at time of publication. Your machine may have product improvements and features not yet contained in this manual.

Vermeer Corporation reserves the right to make changes at any time without notice or obligation.

Operation instructions are included in the two operator's manuals provided with the machine. The tethered (cabled) manual must remain attached to the machine for ready reference. Store it in the manual storage box when not in use.

Lubrication and maintenance procedures are in the maintenance manual provided with the machine. Refer to it for all lubrication and maintenance procedures.

Additional copies of the manuals are available from your dealer. Use the reorder number on the front cover to order additional manuals.

Copies of this manual are available in Spanish from your dealer. Other languages may also be available.

Se dispone de ejemplares de este manual en español.

Notice to owner

Replacement manuals are free of charge by registering your **used** Vermeer machine. Your machine's operator's, maintenance and parts manuals may be available online at www.myvermeer.com. For questions about online or printed manuals, or to register a used machine, contact the data analytics department by telephone: 800-829-0051 or 641-628-3141; email: dataanalytics@vermeer.com; internet: www.vermeer.com or www.myvermeer.com; or, letter: Data analytics department, Vermeer Corporation, P.O. Box 200, Pella, IA 50219 USA.



Orientation: Right and left sides of the machine are determined by facing in the direction of forward travel. The attachment is at the front of machine.

Trademarks

Vermeer, the Vermeer logo and Equipped to Do More are trademarks of Vermeer Manufacturing Company in the U.S. and/or other countries.

Kohler and Command Pro are trademarks of Kohler Co.

Vermeer new industrial equipment limited warranty

Effective November 1, 2021

Warranty period: 12 months / 1000 hours

Vermeer Corporation (hereinafter "Vermeer") warrants each new Industrial product of Vermeer's manufacture to be free from defects in material and workmanship, under normal use and service for one (1) full year after initial purchase/retail sale or 1000 operating hours, whichever occurs first. This Limited Warranty shall apply only to complete machines of Vermeer's manufacture, parts are covered by a separate Limited Warranty. **EQUIPMENT AND ACCESSORIES NOT OF VERMEER'S MANUFACTURE ARE WARRANTED ONLY TO THE EXTENT OF THE ORIGINAL MANUFACTURER'S WARRANTY AND SUBJECT TO THEIR ALLOWANCE TO VERMEER ONLY IF FOUND DEFECTIVE BY SUCH MANUFACTURER.**

EXTENDED WARRANTY OPTIONS ARE AVAILABLE FOR PURCHASE

WARRANTY TERMS During the Limited Warranty period specified above, any defect in material or workmanship in any warranted item of Vermeer Industrial Equipment not excluded below shall be repaired or replaced at Vermeer's option without charge by any authorized independent Vermeer dealer. The warranty repair or replacement must be made by a Vermeer independent authorized dealer at the dealer's location. Vermeer will pay for replacement parts and such authorized dealer's labor in accordance with Vermeer's labor reimbursement policy. Vermeer reserves the right to supply remanufactured replacement parts as it deems appropriate.

RETAIL PURCHASER RESPONSIBILITY: This Limited Warranty requires proper maintenance and periodic inspections of the Industrial Equipment as indicated in the Operator's/Maintenance Manual furnished with each new Industrial Equipment. The cost of routine or required maintenance and services is the responsibility of the retail purchaser. The retail purchaser is required to keep documented evidence that these services were performed. This Vermeer New Industrial Equipment Limited Warranty may be subject to cancellation if the above requirements are not performed. Vermeer Industrial Equipment with known failed or defective parts must be immediately removed from service.

EXCLUSIONS AND LIMITATIONS

The warranties contained herein shall **NOT APPLY TO:**

- (1) Any defect which was caused (in Vermeer's sole judgment) by other than normal use and service of the Industrial Equipment, or by any of the following; (i) accident (ii) misuse or negligence (iii) overloading (iv) lack of reasonable and proper maintenance (v) improper repair or installation (vi) unsuitable storage (vii) non-Vermeer approved alteration or modification (viii) natural calamities (ix) vandalism (x) parts or accessories installed on Industrial Equipment which were not manufactured or installed by Vermeer authorized dealers (xi) the elements (xii) collision or other accident.
- (2) Any Industrial Equipment whose identification numbers or marks have been altered or removed or whose hour meter has been altered or tampered with.
- (3) Any Industrial Equipment which any of the required or recommended periodic inspection or services have been performed using parts not manufactured or supplied by Vermeer or meeting Vermeer Specifications including, but without limitation, engine tune-up parts, engine oil filters, air filters, hydraulic oil filters and fuel filters.
- (4) New Industrial Equipment delivered to the retail purchaser in which the equipment/warranty registration has not been completed and returned to Vermeer within ten (10) days from the date of purchase.
- (5) Any defect which was caused (in Vermeer's sole judgment) by operation of the Industrial Equipment not abiding by standard operating procedures outlined in the Operator's Manual.
- (6) Engine, battery and tire Limited Warranties and support are the responsibility of the respective product's manufacturer.
- (7) Transportation costs, if any, of transporting to the Vermeer dealer. Freight costs, if any, of transporting replacement parts to the Vermeer dealer.
- (8) The travel time of the Vermeer dealer's service personnel to make a repair on the retail purchaser's site or other location.
- (9) In no event shall Vermeer's liability exceed the purchase price of the product,
- (10) Vermeer shall not be liable to any person under any circumstances for any incidental or consequential damages (including but not limited to, loss of profits, out of service time) occurring for any reason at any time.
- (11) Diagnostic and overtime labor premiums are not covered under this Limited Warranty Policy. Oils and fluids are not covered under this Limited Warranty.

- (12) Depreciation damage caused by normal wear, lack of reasonable and proper maintenance, failure to follow operating instructions, misuse, lack of proper protection during storage.
- (13) Accessory systems and electronics not of Vermeer's manufacture are warranted only to the extent of such manufacturer's respective Limited Warranty if any.
- (14) Down hole toolage is not covered under this warranty.
- (15) Wear items which are listed below:

antenna, augers, base plates, bearing seals, bearings, belts, brake pads, brushes, bolts/torqued parts, boom wear items, booms, brake pads, bushings, buckets, cable fingers, chain, clamping vise parts, clutches, clutch components, conveyor belts, cups, curtains, cutter wheels, dies, digging chain, digging rims, discharge conveyor belts, drive chuck, drums, earth stakes, end idler, end rollers, fan belts, flails, flashings, hammers, hoses, infeed conveyor belts, infeed conveyor chains, jaws, knives, leaf chain, lights, lights on light kits, liners, outer drum bearings, packing assemblies, pins and bushings, pins and pivot points, piston cups, pivot rings, plastic wear strips, plow blades, plungers, pockets, rods, rollers, rod loader parts, roter bands, rotor plates, rubber grouser bars, rubber or plastic items, rubber tracks, rubber track bands, rubber shielding, scraper knives, screens, seals, service items, shear bar/bedknife, skid shoes, sprockets, teeth, tips, tip mounts, tires, thrust wheels, tooling, track chain, track guides, track idlers, track pads, track rollers, track sprockets, trench cleaner (crumber), trip cleaners, trommel brushes, trommel screen panels, trunnion and pivot points, valves, valve seats, water hoses, water swivels, wear bars, wear blocks, wear plates, wear strips, wheels, winch cable, windshield wiper parts.

PARTS WARRANTY:

Parts replaced in the warranty period will receive the balance of the first year New Industrial Equipment Limited Warranty, during the first (12) months or 1000 hours, whichever comes first. Replacement parts after the original machine warranty, are warranted to be free from defects of material for ninety (90) days or the part will be repaired or replaced, without labor coverage for removal and reinstallation.

EXCLUSIONS OF WARRANTIES: EXCEPT FOR THE WARRANTIES EXPRESSLY AND SPECIFICALLY MADE HEREIN, VERMEER MAKES NO OTHER WARRANTIES, AND ANY POSSIBLE LIABILITY OF VERMEER HEREINUNDER IS IN LIEU OF ALL OTHER WARRANTIES, EXPRESS, IMPLIED, OR STATUTORY, INCLUDING, BUT NOT LIMITED TO, ANY WARRANTIES OF MERCHANTABILITY OR FITNESS FOR A PARTICULAR PURPOSE. VERMEER RESERVES THE RIGHT TO MODIFY, ALTER AND IMPROVE ANY PRODUCT WITHOUT INCURRING ANY OBLIGATION TO REPLACE ANY PRODUCT PREVIOUSLY SOLD WITH SUCH MODIFICATION. NO PERSON IS AUTHORIZED TO GIVE ANY OTHER WARRANTY, OR TO ASSUME ANY ADDITIONAL OBLIGATION ON VERMEER'S BEHALF.

NO DEALER WARRANTY. The selling dealer makes no warranty of its own and the dealer has no authority to make any representation or promise on behalf of Vermeer or to modify the terms or limitations of this warranty in any way.

ELECTRONIC SIGNATURES. Each of the parties hereto expressly agrees to conduct transactions by electronic means. Accordingly, the parties agree and intend that all electronic transmissions including, without limitation, electronic signatures, shall be considered equivalent to an original writing as provided under Iowa law, as it may be amended from time to time.

Manufactured by:
Vermeer Corporation. All Rights Reserved.
1210 Vermeer Road East, P.O. Box 200
Pella, Iowa 50219-0200 USA

VERMEER TWO-YEAR EVAPORATIVE EMISSION CONTROL WARRANTY STATEMENT

YOUR WARRANTY RIGHTS AND OBLIGATIONS

EFFECTIVE JANUARY, 2022

This evaporative emissions-related warranty is for models of Vermeer equipment that (a) are delivered to the United States and Canada and (b) contain gasoline fueled engines and fuel systems covered by Certificates of Conformity issued by the US EPA. This warranty is in addition to the Vermeer New Industrial Equipment Limited Warranty. The US EPA and Vermeer are pleased to explain the evaporative emission control system (EECS) warranty on your Vermeer equipment. Vermeer must warrant the EECS on your equipment for the period of time listed below provided there has been no abuse, neglect or improper maintenance of your equipment. Your EECS may include components such as the fuel lines, fuel caps, canisters, vapor hoses, clamps, connectors, and other associated evaporative emission-related components. Where a warrantable condition exists, Vermeer will repair your equipment at no cost to you including diagnosis, components and labor.

MANUFACTURER'S WARRANTY COVERAGE:

This EECS is warranted for two years. If any EECS component on your equipment is defective, the component will be repaired or replaced by Vermeer.

OWNER'S WARRANTY RESPONSIBILITIES:

As the equipment owner, you are responsible for performance of the required maintenance listed in your owner's manual. You may choose any qualified repair shop or person to maintain, replace, or repair emission control devices and systems with original or equivalent replacement components. Vermeer recommends that you retain all receipts covering maintenance on your equipment, but Vermeer cannot deny warranty solely for the lack of receipts.

However, warranty, recall and all other services paid for by Vermeer must be performed at an authorized Vermeer service provider. As the equipment owner, you should however be aware that Vermeer may deny your warranty coverage if your equipment or a component has failed due to abuse, neglect, or improper maintenance or unapproved modifications.

You are responsible for presenting your equipment to an authorized Vermeer dealer or distributor as soon as the problem exists. The warranty repairs should be completed in a reasonable amount of time, not to exceed 30 days. If you have a question regarding your warranty coverage, you should contact the Vermeer Customer Data Department at 1-800-829-0051.

GENERAL EMISSIONS WARRANTY COVERAGE:

Vermeer warrants to the ultimate purchaser and each subsequent purchaser that the equipment is:

Designed, built and equipped so as to conform with all applicable regulations; and

Free from defects in materials and workmanship that cause the failure of a warranted component to be identical in all material respects to that component as described in Vermeer's application for certification.

The warranty period begins on the date the equipment is delivered to an ultimate purchaser or first placed into service. The warranty period is two years.

Subject to certain conditions and exclusions as stated below, the warranty on emission-related components is as follows:

- (1) Any warranted component that is not scheduled for replacement as required maintenance in the written instructions supplied, is warranted for the warranty period stated above. If the component fails during the period of warranty coverage, the component will be repaired or replaced by Vermeer according to subsection (4) below. Any such component repaired or replaced under warranty will be warranted for the remainder of the period.
- (2) Any warranted component that is scheduled only for regular inspection in the written instructions supplied is warranted for the warranty period stated above. Any such component repaired or replaced under warranty will be warranted for the remaining warranty period.
- (3) Any warranted component that is scheduled for replacement as required maintenance in the written instructions supplied is warranted for the period of time before the first scheduled replacement date for that component. If the component fails before the first scheduled replacement, the component will be repaired or replaced by Vermeer according to subsection (4) below. Any such component repaired or replaced under warranty will be warranted for the remainder of the period prior to the first scheduled replacement point for the component.

Repair or replacement of any warranted component under the warranty provisions herein must be performed at a Vermeer authorized warranty station at no charge to the owner.

- (4) Notwithstanding the provisions herein, warranty services or repairs will be provided at all of our distribution centers that are franchised to service the subject engines or equipment.
- (5) The equipment owner will not be charged for diagnostic labor that is directly associated with diagnosis of a defective, emission-related warranted component, provided that such diagnostic work is performed at a warranty station.
- (6) Throughout the equipment warranty period stated above, Vermeer will maintain a supply of warranted components sufficient to meet the expected demand for such components.
- (7) Any replacement component may be used in the performance of any warranty maintenance or repairs and must be provided without charge to the owner. Such use will not reduce the warranty obligations of Vermeer.

WARRANTED COMPONENTS:

The repair or replacement of any warranted component otherwise eligible for warranty coverage may be excluded from such warranty coverage if Vermeer determines that the cause of the need for equipment repair or replacement was abuse, neglect, improper maintenance, improper components, improper use or continued use when a problem is evident. That notwithstanding, any adjustment of a component that has a factory installed, and properly operating, adjustment limiting device is still eligible for warranty coverage. The following EECS components are covered: (1) Fuel Cap, (2) Fuel Line, (3) Fuel Tank, (4) Rollover Valve, and (5)

Fittings, clamps, gaskets, grommets, and mounting hardware associated with systems above.

The exclusive remedy for breach of this limited warranty shall be, at the exclusive option of Vermeer, repair or replacement of any defective materials, components or products. THE REMEDIES SET FORTH IN THIS LIMITED WARRANTY ARE THE ONLY REMEDIES AVAILABLE TO ANY PERSON FOR BREACH OF THIS EMISSIONS WARRANTY. VERMEER SHALL HAVE NO LIABILITY TO ANY PERSON FOR INCIDENTAL, CONSEQUENTIAL OR SPECIAL DAMAGES OF ANY DESCRIPTION, WHETHER ARISING OUT OF EXPRESS OR IMPLIED WARRANTY OR ANY OTHER CONTRACT, NEGLIGENCE OR OTHER TORT OR OTHERWISE. THIS EXCLUSION OF CONSEQUENTIAL, INCIDENTAL, AND SPECIAL DAMAGES IS INDEPENDENT FROM AND SHALL SURVIVE ANY FINDING THAT THE EXCLUSIVE REMEDY FAILED OF ITS ESSENTIAL PURPOSE. ALL IMPLIED WARRANTIES (INCLUDING BUT NOT LIMITED TO ANY IMPLIED WARRANTIES OF MERCHANTABILITY AND FITNESS FOR A PARTICULAR PURPOSE) ARE LIMITED IN DURATION TO THE WARRANTY PERIOD DESCRIBED HEREIN.

Telematics equipment notice and consent

This machine is equipped with Vermeer GPS tracking equipment that collects and transmits data about the machine's performance and location. This data is collected by Vermeer and held, used and shared consistently with the terms of the Vermeer Privacy Policy and any applicable provisions of the End User License Agreement ("EULA") which may be found at: <http://www2.vermeer.com/vermeer/NA/en/N/privacy> and <http://telematics.vermeer.com>.

Machine owner and designated representatives ("subscribers") may access the data through a subscription based website called Vermeer Telematics (formerly known as Vermeer Fleet/Fleet Edge). Use of Vermeer Telematics is subject to the subscriber's acceptance of the terms and conditions of use and payment of any applicable subscription or license fees. If you are a current subscriber, you may obtain a copy of the currently effective terms and conditions through your login or by contacting appsupport@vermeer.com.

More information about Vermeer Telematics may be found at: <http://store.vermeer.com>.

Machine owner may opt-out of the telematics service and collection of data by Vermeer Telematics at any time by contacting your Vermeer dealer or appsupport@vermeer.com.

This page intentionally left blank.

Receiving and delivery report

Dealer prep

Check or perform the following:

- ___ Check machine for shortage or damage in transit.
- ___ Check adjustment of trencher digging chain and auger.
- ___ Check installation and adjustment of trencher restraint bar.
- ___ Check installation and condition of all shields.
- ___ Check machine for proper lubrication.
- ___ Check condition of all safety signs and decals.
- ___ Check all phases of operation.
- ___ Check for loose hardware.
- ___ Check adjustment and operation of *neutral start switches*.
- ___ Check battery condition and terminal connections (if equipped).
- ___ Check that operator's manual is cabled to the machine.
- ___ Check wheel lug nuts tightness (70 ft-lb/95 Nm).
- ___ Check drive wheel tires (if equipped) for proper air pressure: 12 psi (80 kPa) maximum.
- ___ Check track tension (if equipped).
- ___ Check *handgrip operator presence control* for proper operation.
- ___ Check that machine does not move when the *ground drive lever* is in neutral and engine is at full throttle.
- ___ Check that digging chain does not move when *digging chain drive lever* is in neutral and engine is at full throttle.

Engine

- ___ Check oil level of the engine.
- ___ Check condition of the air cleaner.
- ___ Check engine for proper operation.

Hydraulics

- ___ Check hydraulic fluid level.
- ___ Check *control levers* for proper operation.
- ___ Check all hydraulic components for leaks or damage.

Review of operation

Review and demonstrate with the customer the various aspects of tractor operation:

- ___ overall explanation of how the machine works
- ___ overall explanation of how trencher works
- ___ tractor and trencher safety
- ___ preparing the machine and trencher for operation

Dealer/Owner information

dealer

address

city

state/province

zip/postal code

country

phone number

email address

owner

address

city

state/province

zip/postal code

country

phone number

email address

Machine identification numbers - record

Machine model number _____

Machine serial number _____

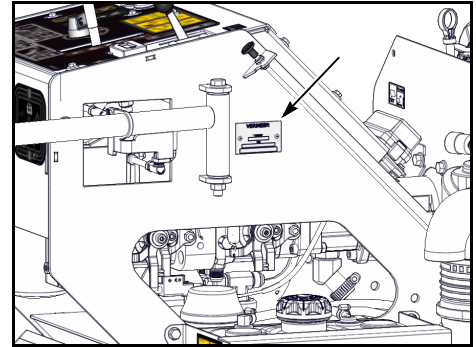

Backfill blade (option) model number _____

Backfill blade (option) serial number _____

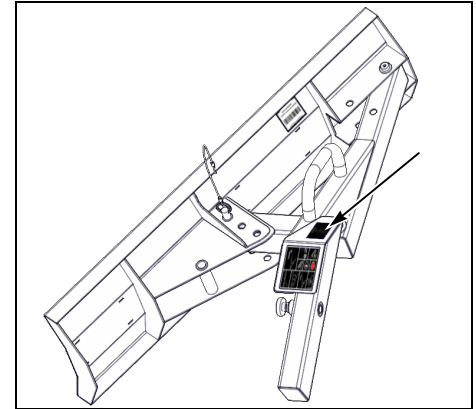

Engine identification number - record

Engine model number _____

Engine serial number _____

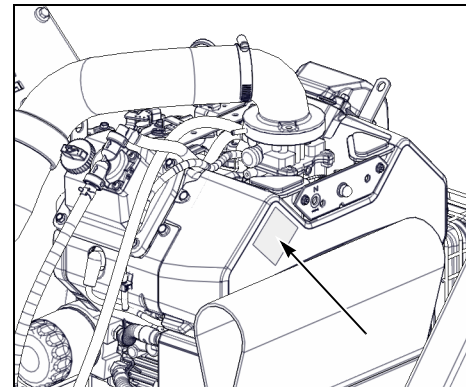

Identification decals

These decals provide easy identification of the model and 17-digit identification number for the machine and attachments. The barcode contains the VIN number and can be scanned with any barcode reading device.

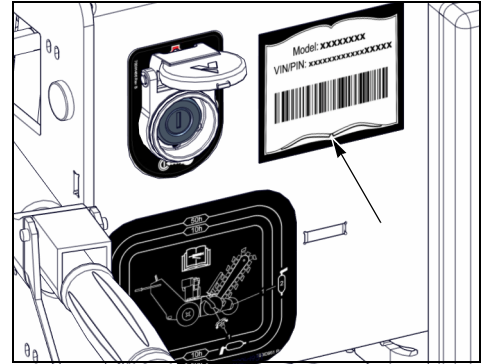

Machine identification decal

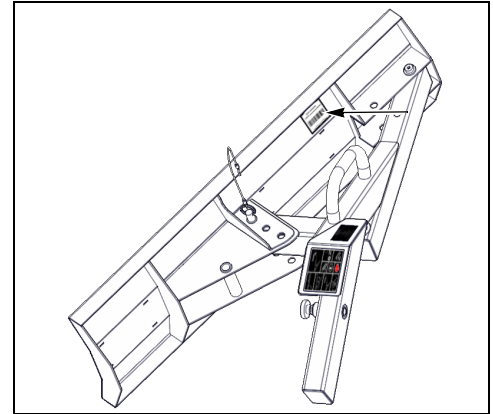

Backfill blade (option) identification decal

Table of contents

Receiving and delivery report	i
Dealer prep	i
Engine	ii
Hydraulics	ii
Review of operation	ii
Dealer/Owner information	iii
Machine identification numbers - record	iv
Engine identification number - record	v
Identification decals	vi
Safety messages	10-1
Safety symbol explanation	10-1
Crystalline silica	10-5
Intended use	15-1
Vermeer productivity tools	16-1
Vermeer GPS tracking equipment (telematics)	16-1
Controls	20-1
Engine controls	20-1
Machine controls	20-3
Starting procedure	22-1
Starting the engine	22-1
After engine starts	22-2
Cold-weather starting	22-3
Engine	22-3

Hydraulic fluid	22-3
Jump-starting	22-4
Avoid battery explosion	22-4
Avoid battery burns	22-5
Jump-starting procedure	22-5

Shutdown procedure

23-1

Transporting the machine

30-1

Driving the machine	30-1
Steering the machine	30-2
Safe operation on slopes	30-3
Trailing the machine	30-4
Loading	30-4
Unloading	30-5
Lifting - single point lift assembly (optional)	30-6
Emergency towing	30-7

Preparing machine and work area

40-1

Operator qualifications	40-1
Personal protection	40-2
Sound and vibration levels	40-3
Operator presence switch - check	40-4
Prepare the area	40-4
Underground utility contact	40-5
Look for evidence of underground placement	40-6
Striking a utility	40-7
Electricity	40-7

Gas	40-7
Fiber optic	40-8
Jobsite assessment	40-8
Prepare the machine	40-10
Clean machine.	40-10
Fuel tank - fill	40-11
Operating the trencher.	50-1
Operate safely	50-1
Trenching tips.	50-2
Trenching	50-3
Trench cleaner assembly/restraint bar	50-3
Trench - start/plunge cut	50-3
Trench cleaner - adjust	50-5
Trench - complete	50-5
Freezing temperature precautions.	50-5
Backfill blade (option)	55-1
Backfill blade - install/remove	55-1
Backfill blade operation.	55-4
Backfilling	55-4
Maintenance intervals	60-1
Welding precautions - review	60-1
Safety signs maintenance.	60-2
Maintenance manual	60-2
Engine maintenance intervals.	60-2
Greasing the machine.	60-3
Recommended fluids	60-3
Hourmeter - check for maintenance interval/reset (SN 101–310).	60-3

Hourmeter - check for maintenance interval (SN 311–).	60-4
Maintenance intervals	60-4

Section 10: Safety messages

General safety messages appear in this section. Specific safety messages are located in appropriate sections of the manual where a potential hazard may occur if the instructions or procedures are not followed.

A signal word **DANGER**, **WARNING** or **CAUTION** is used with the safety alert symbol.

Safety signs with signal word **DANGER**, **WARNING** or **CAUTION** are located near specific hazards.

- DANGER** Indicates a hazardous situation that, if not avoided, will result in death or serious injury.
- WARNING** Indicates a hazardous situation that, if not avoided, could result in death or serious injury.
- CAUTION** Indicates a hazardous situation that, if not avoided, could result in minor or moderate injury.
- NOTICE** Indicates information considered important, but not hazard-related.

Safety symbol explanation



This is the safety alert symbol. This symbol is used in combination with an exclamation mark or other symbols to alert you to the potential for death or serious injury.



This symbol indicates that at least one part of the machine is not operating correctly. Shutting down the machine may not be necessary, but some maintenance may be required.

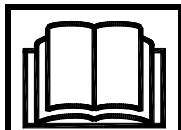

WARNING: Read operator's manual and safety signs before operating machine.

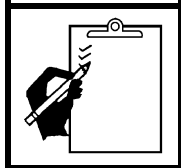

WARNING: Check machine before operating. Machine must be in good operating condition and all safety equipment installed and functioning properly.

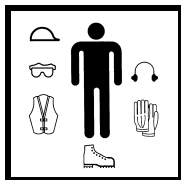

WARNING: Wear personal protective equipment. Wear close-fitting clothing and confine long hair. Additional personal protection requirements are explained separately. Refer to "Personal protection," [page 40-2](#).

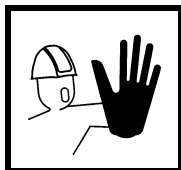

WARNING: Keep spectators away.



WARNING: Engine exhaust can asphyxiate or poison resulting in death or serious injury. Operate machine outdoors. If it is necessary to operate engine in an enclosed area, properly vent exhaust gases.

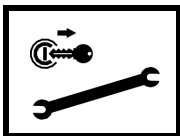

WARNING: Failure to use shutdown procedure can result in unexpected hazard(s). Death or serious injury could result due to entanglement, crushing, cutting, or other hazardous contact. Follow Shutdown Procedure after operating, before performing any service or maintenance, and before transporting. Refer to [Shutdown procedure](#), page 23-1.



WARNING: Pressurized fluid can penetrate body tissue and result in death or serious injury. Leaks can be invisible. Keep away from any suspected leak. Relieve pressure in the hydraulic system before searching for leaks, disconnecting hoses, or performing any other work on the system. If you must pressurize the system to find a suspected leak, use an object such as a piece of wood or cardboard rather than your hands. When loosening a fitting where some residual pressure may exist, slowly loosen the fitting until oil begins to leak. Wait for leaking to stop before disconnecting the fitting. Fluid injected under the skin must be removed immediately by a surgeon familiar with this type of injury.

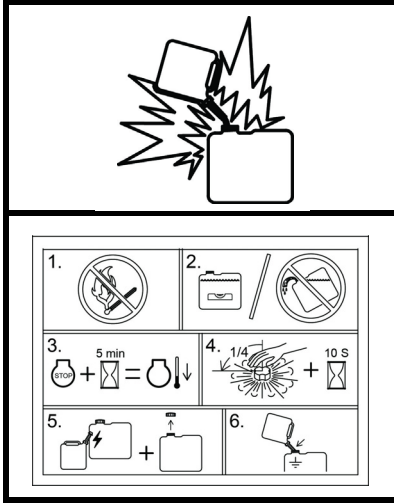

WARNING: Fuel and fumes can explode and burn. Refer to “Fuel tank - fill,” [page 40-11.](#)

No flame. No smoking. Fill with machine level, do not overfill. Stop engine and let cool for 5 minutes. Turn fuel cap 1/4 turn, wait 10 seconds. Touch spout to tank to discharge static, then remove cap. Keep spout in contact with tank while filling.

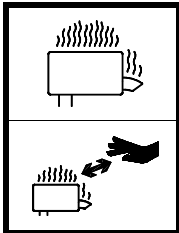

CAUTION: Hot muffler can burn.

Stay away.

Crystalline silica

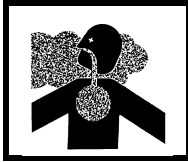

WARNING: Breathing crystalline silica puts workers at increased risk of developing serious silica-related diseases including: silicosis, lung cancer, kidney disease, Chronic Obstructive Pulmonary Disease (COPD). Death or serious illness could result. Avoid exposure to crystalline silica dust according to OSHA guideline 29 CFR 1926.1153.

Breathing crystalline silica dust over time can result in silicosis, a disabling, non-reversible and sometimes fatal disease of the lungs. United States Federal OSHA has established exposure limits for employees. Avoid exposure to dust containing crystalline silica in excess of these limits.

Crystalline silica is a basic component of sand, rock, concrete, brick, block and mortar. Many activities at construction sites such as breaking, chipping, drilling, cutting, etc., produce dust containing crystalline silica. Air monitoring may be necessary to determine whether jobsite conditions expose workers to excessive levels of crystalline silica dust. Depending upon air monitoring results, the following measures may be necessary to avoid exposure to excessive levels of crystalline silica dust:

- Perform an exposure assessment.
- Create a written exposure control plan.
- Complete housekeeping.
- Conduct medical surveillance.
- Complete employee training.

Be aware of and follow the guidelines of United States OSHA 29CFR1926.55 and 1926.1153, or other applicable regulatory guidelines. This includes having a jobsite plan for mitigating hazards.

- A jobsite plan can include jobsite dust reduction measures including using water spray, vacuum or other methods.
- If possible, change into disposable or washable clothes on the jobsite. Shower and change into clean clothing before leaving the jobsite.

- Do not eat, drink, use tobacco products or apply cosmetics in areas where there is dust containing crystalline silica dust. Wash hands before eating, drinking or using these products.

Store food, drink and personal belongings away from the work area.



WARNING: Be sure that all safety devices, including shields, are installed and functioning properly after servicing the machine.



WARNING: Make no modifications to your equipment unless specifically recommended or requested by Vermeer Corporation.



WARNING: Failure to follow any of the preceding safety instructions or those that follow within this manual, could result in death or serious injury. This machine is to be used only for those purposes for which it was intended as explained in this operator's manual.

Section 15: Intended use

The RTX200 is a self-propelled rubber tire or track machine intended to be used solely to produce an open trench in a continuous operation with rearward motion of the machine.

The RTX200 backfill blade attachment is intended to be used solely to push earthen material, typically to return excavated material back into the trench.

Always use the machine in accordance with the instructions contained in this manual, safety signs on the machine and other material provided by Vermeer Corporation.

Proper maintenance and repair are essential for safety and efficient machine operation. Do not use the machine if it is not in suitable operating condition.

This page intentionally left blank.

Section 16: Vermeer productivity tools

Vermeer GPS tracking equipment (telematics)

- Serial numbers 1001 and up are equipped with Vermeer GPS tracking equipment.

Vermeer uses GPS tracking equipment to collect data about the machine's performance and location. When activated, the telematics control unit (TCU) transmits the data to a subscription-based website called Vermeer Telematics (formerly known as Vermeer Fleet/Fleet Edge). Subscribers can access the data through a computer or mobile device.

Each subscription is valid for a current registered owner's specific machine. The subscription cannot be transferred to another machine or to a new machine owner.

- After subscribing, go to <http://telematics.vermeer.com> and refer to the bulletin for instructions on accessing the user's guides.
- Subscriptions can be canceled at any time by contacting your local Vermeer dealer or emailing appsupport@vermeer.com.
- Subscribers must notify appsupport@vermeer.com to cancel a subscription when selling a machine.

There are two levels of data access, as well as a third option which turns off the system.

- Full Implementation - The subscription owner, Vermeer and authorized dealers can all access the data. A new machine, manufactured by Vermeer Corporation and equipped with telematics, automatically begins transmitting data to Vermeer and its authorized dealer. The owner must activate the subscription to access the data. For more information on subscribing, contact your Vermeer dealer or email appsupport@vermeer.com.
- Partial implementation - Only the registered owner and Vermeer Corporation can access the data. To select this option, contact your dealer or email appsupport@vermeer.com.
- Shut system off - To discontinue data collection and turn off the system, email appsupport@vermeer.com.

Used machines - to activate machine telematics after purchasing a used machine:

Step 1: View the compatible machine list online at <http://store.vermeer.com>, or contact your local Vermeer dealer or email appsupport@vermeer.com to determine if machine telematics is available for installation.

Step 2: Contact your Vermeer dealer or email appsupport@vermeer.com to ensure that any previous subscription related to your machine has been canceled.

For more information, contact your Vermeer dealer or email appsupport@vermeer.com.

Section 20: Controls

Engine controls

(1) *Keyswitch*

Counterclockwise **engine and electrical system off**

Vertical position **electrical system on**

Clockwise from vertical position **starts engine**
Key returns to vertical position when released.

(2) *Throttle lever*



Push forward **increase engine speed**



Pull back **decrease engine speed**

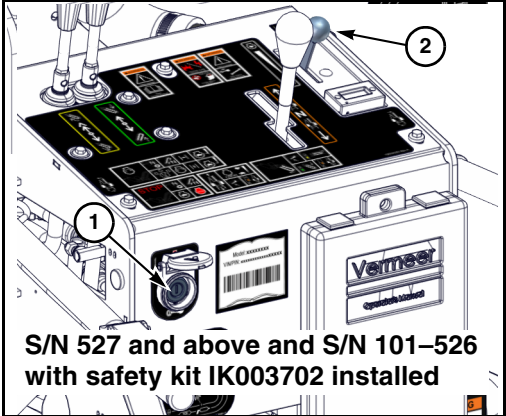

(3) Choke

Push in full open

Pull out close

(4) Hourmeter

Records total machine operation time.

(5) Low oil pressure warning light

Light indicates low pressure when the *ignition switch* is on. If the light does not shut off within 30 seconds after starting the engine, shut off the engine and correct the issue.

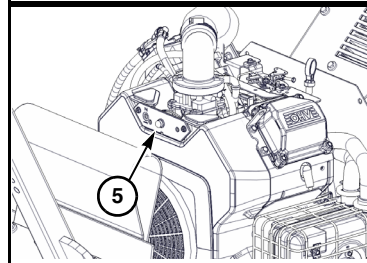
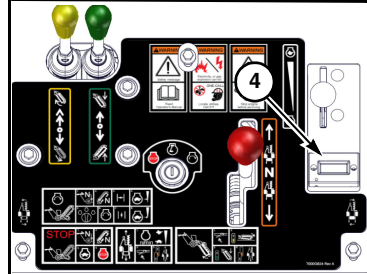
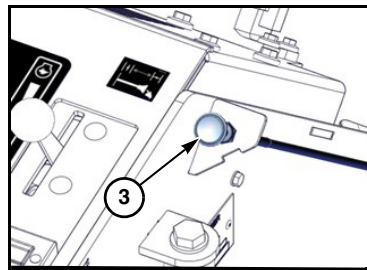
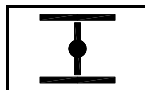
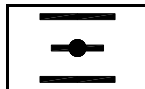
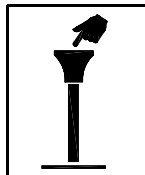

Machine controls

(1) *Trencher lift lever* (green)



Push forward **lower trencher boom**



Pull back..... **raise trencher boom**

Lever will spring return to neutral when released.

(2) *Digging chain drive lever* (yellow)



Push forward to detent **engage digging chain**

Center (neutral) stop digging chain



Pull back..... **momentarily reverse chain**

- *Lever will spring return to neutral from reverse position.*
- *Lever must be in neutral before engine will start.*

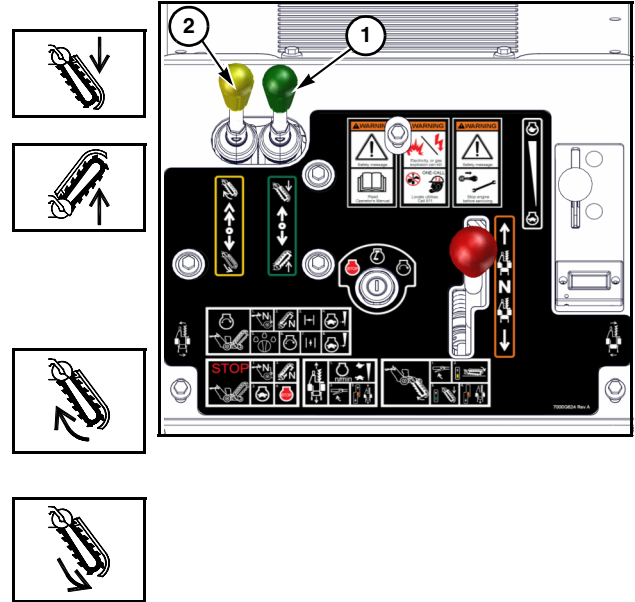

(3) *Propel lever (orange)*



Push forward **variable speed forward**

Center **neutral**



Pull back **variable speed reverse**

Lever must be in neutral before engine will start.

(4) *Operator presence lever (left side)*

Squeeze red lever under handlebar grip to allow engine to run when *ground drive control* or *digging chain drive control* is engaged.

(5) *Handlebars*

Pivot handlebars to steer, rotating rear of machine in direction of push.

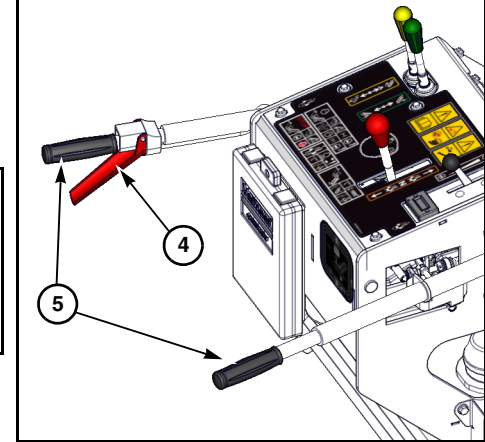
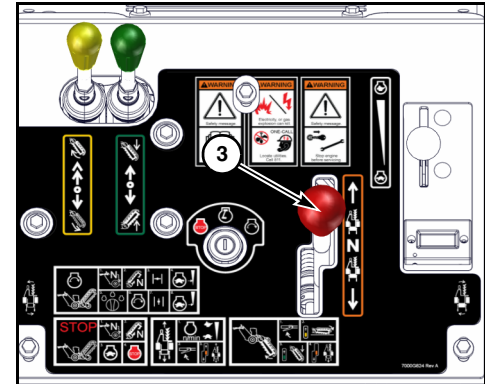
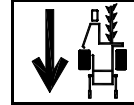
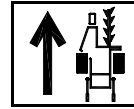
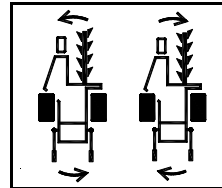

Section 22: Starting procedure

Starting the engine

- Step 1:** Place *propel lever* in neutral.
- Step 2:** Place *digging chain drive lever* in neutral.
- Step 3:** Fully close *choke* (cold engine only).
- Step 4:** Move *throttle lever* to 1/4 speed.
- Step 5:** Turn *keyswitch* to on position.

Do not squeeze *operator presence lever* while starting machine.

- Step 6:** Turn *keyswitch* to start position to start machine. Release *switch* when engine starts.

NOTICE: Do not crank engine continuously for more than 10 seconds at a time. If the engine does not start, allow a 60-second cool-down period between starting attempts. Failure to follow these guidelines can damage the starter motor.

- Step 7:** After engine starts, gradually open *choke*.

If engine fails to start in three attempts, turn *switch* off and check for fuel blockage or issues with ignition system.

- Step 8:** Reduce *throttle* to idle.

- Do not operate engine under load until engine has warmed up.
- For cold-weather starting, refer to *Engine cold-weather starting* in this section.

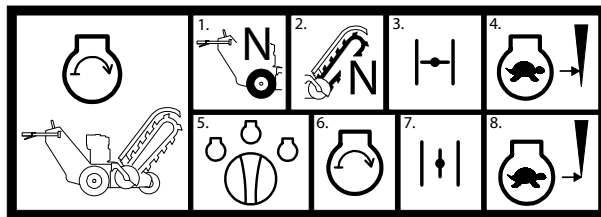

After engine starts

- Check operation of *operator presence controls*. The engine must stop if the *operator presence lever* is released while the *ground drive lever* or *digging chain drive lever* is engaged. This system is intended for your safety and must be maintained in good functional condition. Contact your Vermeer dealer if it does not function correctly. Check that machine does not move with *propel lever* in neutral.
- Check that trencher digging chain does not turn with *digging chain drive control* in neutral.

Cold-weather starting

Engine

Before operating in cold weather, refer to the engine operation manual for recommended engine oil, fuel and starting procedures.

Hydraulic fluid

Refer to *Lubricants*, specifications section in the maintenance manual for recommended hydraulic fluids.

When using ISO 68 hydraulic fluid below +23°F (-5°C):

- Warm up engine.
- Gradually increase engine rpm, and allow hydraulic oil to warm up for 30 minutes.

NOTICE:

- Reduce engine speed if hydraulic pump whines. Pump noise may indicate lack of oil which can damage the pump.
- Do not spray starting fluid into the air cleaner. Engine damage can result.

Jump-starting

Avoid battery explosion



WARNING: Battery fumes are flammable and can explode. Keep all burning materials away from battery. Battery explosion can blind. Acid can blind and burn. Tools and cable clamps can make sparks.

Do not smoke. Shield eyes and face. Read instructions.

Do not jump-start or charge a battery that is frozen or low on electrolyte.

Avoid explosion hazard. If equipped with battery caps, they must be in place and tight.

NOTICE: Use only a 12-volt system for jump-starting. Do not allow vehicle used to jump-start to be in contact with the disabled machine. Vehicles in contact have a ground connection which allows a spark to occur at the battery when the positive jumper cable is connected or removed. If equipped with battery caps, they must be in place and tight to reduce risk of battery explosion.

Avoid battery burns

Battery contains sulfuric acid which can cause severe burns. Avoid contact with eyes, skin and clothing.

In case of acid contact:

External: Flush with plenty of water. If eyes have been exposed, flush with water for 15 minutes and get prompt medical attention.

Internal: Drink large quantities of water or milk, follow with milk of magnesia, beaten egg or vegetable oil. Call a physician immediately.

Jump-starting procedure

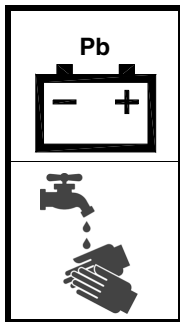

WARNING: Battery post, terminals, and related accessories contain lead and lead compounds.

Wash hands after handling.

Step 1: Turn *keyswitch* to off and remove battery access cover.

Step 2: Connect jumper cables in the following order:

- Red to discharged battery positive (+) terminal **(1)**.
- Red to boost battery positive (+) terminal **(2)**.
- Black to boost battery negative (-) terminal **(3)**.
- Black to frame **(4)** of machine with the discharged battery. Make connection away from battery.

NOTICE: To avoid sparks near battery, disconnect black jumper cable at point **(4)** before adjusting red cable at point **(1)**.

Step 3: Start engine.

Step 4: Remove cables in reverse order and install covers over cable clamps.
Install battery access cover.

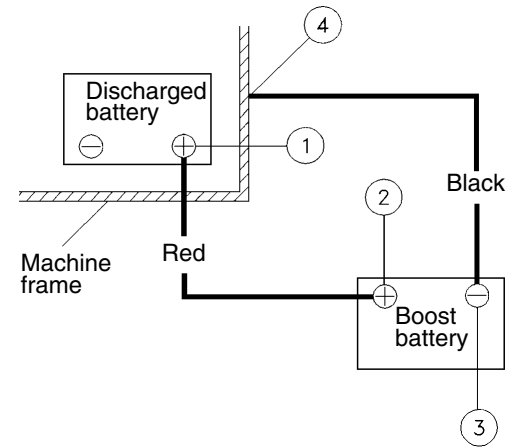

Section 23: Shutdown procedure

For your safety and the safety of others, follow shutdown procedure before working on the machine for any reason, including servicing, maintaining, cleaning, inspecting, unclogging or transporting machine, or as otherwise directed in operator's manual.

A variation of this procedure may be used if so instructed within this manual or if an emergency requires it.

- Step 1:** Place *propel lever* in neutral.
- Step 2:** Place *digging chain drive lever* in neutral.
- Step 3:** Lower trencher boom to the ground.
- Step 4:** Reduce engine speed to idle.
- Step 5:** Turn *keyswitch* to off and remove key.

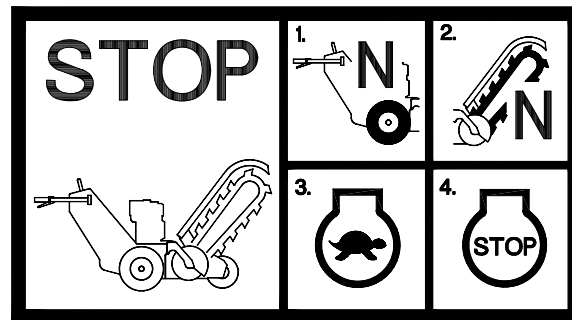

If shutting down on a slope, turn machine to face across the slope to prevent machine from creeping away from the parked position. If this is not possible on the track version due to lack of engine power, install pin (1) on left side track to engage sprocket. If pin does not go all the way through, push the unit forward or backward slightly until pin will fully engage. Remove pin and place in bracket. Secure with clip (2) before moving machine.

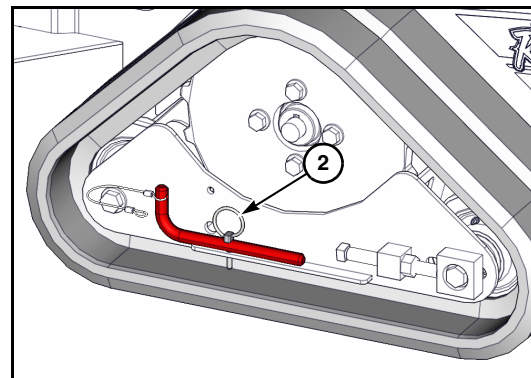
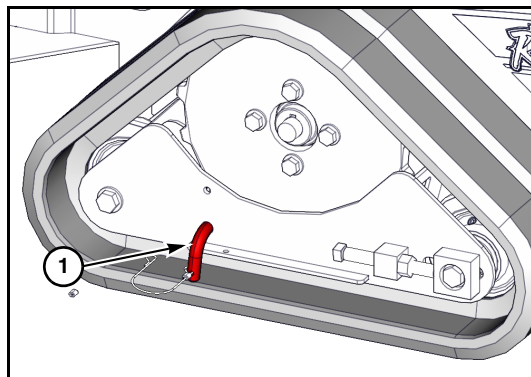

Section 30: Transporting the machine

Driving the machine



WARNING: Rollover can crush.

Do not allow anyone to ride on machine.



WARNING: Runover can crush.

Keep feet away from wheels or tracks.

Step 1: Refer to “Starting procedure,” [page 22-1](#).

Step 2: Increase engine rpm.

Step 3: Fully raise trencher boom.



WARNING: Rollover can crush. Avoid situations where rollover can occur.

Step 4: Set *throttle* to desired engine speed (1).

Step 5: Squeeze red *operator presence lever* (2) on left handle.

- Machine will shut off if *propel lever* or *steering controls* are moved out of neutral if the *operator presence lever* is not engaged.

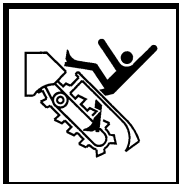

DANGER: Never move machine with digging chain engaged. Contact with moving digging chain will result in death or serious injury.

Step 6: Use *propel lever* (3) to move machine.

Until the operator has become familiar with the *controls* and understands the capability of the machine, use a slower ground speed to move machine.

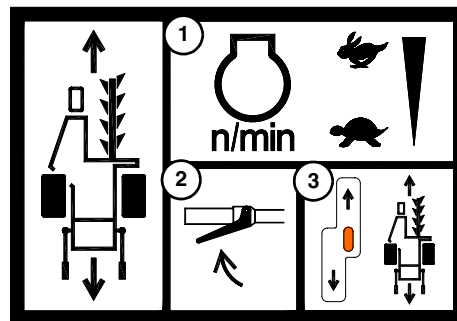

Steering the machine

Pivot handlebars to steer, rotating rear of machine in direction of push. Machine will counter-rotate if *propel lever* is in neutral.

Safe operation on slopes

Safe operation on slopes depends on several factors, including:

Machine weight distribution including front loading or absence of load

Height of load

Even or rough ground conditions

Potential for ground giving way, causing unplanned forward, reverse or sideways tilt

Proximity of ditches, ruts, stumps or other obstructions and sudden changes in slope

Speed

Turning

Braking performance

Operator skill

Notice: The previous varying factors make it impractical to specify a maximum safe operating angle in this manual. It is important for the operator to be aware of these conditions and adjust operation accordingly. Maximum engine angle and braking performance are two absolute limits which should never be exceeded. These maximums are stated below since they are **design limits**. These angles are **not operating limits** and therefore must never be used alone to establish safe operating angles for varying conditions.

Maximum engine lubrication angle - 20° all directions.

Trailing the machine

Loading

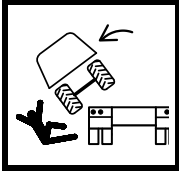

WARNING: Unintended machine movement may occur when loading or unloading on slippery, dirty or uneven trailer surfaces. Death or serious injury can result if struck or crushed by machine. Ensure trailer is level and all loading surfaces are clean and free of debris. Do not attempt to load onto slippery trailer surfaces. Use smooth and controlled steering movements.

- Read the towing vehicle and trailer manuals for safety precautions and information.
- Ensure gross weight of the machine with attachments is within the weight limits of the trailer and towing vehicle.
- Properly attach trailer to towing vehicle and chock wheels or set park brake of towing vehicle.
- Ensure you are qualified to operate the machine. Refer to “Operator qualifications,” [page 40-1](#).
- Keep attachment(s) as low as practical while loading and unloading.
- Slowly drive machine on and off trailer squarely to minimize steering.
- Do not attempt to steer machine when balance at trailer/ramp transition.
- Position machine at location for tie-downs and weight distribution as recommended by trailer manufacturer.

Machine weights are included in the specifications section of the maintenance manual. These weights can be used to determine the approximate gross weight of a vehicle configuration.

Step 1: Refer to “Starting procedure,” [page 22-1](#).

Step 2: Position machine in-line with the trailer ramps.

Step 3: Set *throttle* to half speed. Use *propel lever* to move machine.

Step 4: Drive machine squarely onto trailer.

Step 5: Stop machine when tie-down position is reached. The tie-down position distributes weight on the trailer as recommended by the trailer manufacturer.

Step 6: Lower trencher boom to trailer.

Step 7: Shut off engine.

Step 8: Fasten machine to the trailer using one front (1) and two rear (2) tie-down points.

Unloading

Step 1: To unload machine, place trailer on a level surface.

Step 2: Remove chains.

Step 3: Refer to “Starting procedure,” [page 22-1](#).

Step 4: Set *throttle* to half speed.

Step 5: Raise the trencher boom to avoid having to raise while moving machine off the trailer.

Step 6: Align machine with trailer ramps.

Step 7: Use *propel lever* to slowly move machine down the ramp to the ground. Minimize steering while on the ramps. Steering while on the ramps may result in the machine driving off the ramps or cause the ramps to move and drop off the trailer deck.

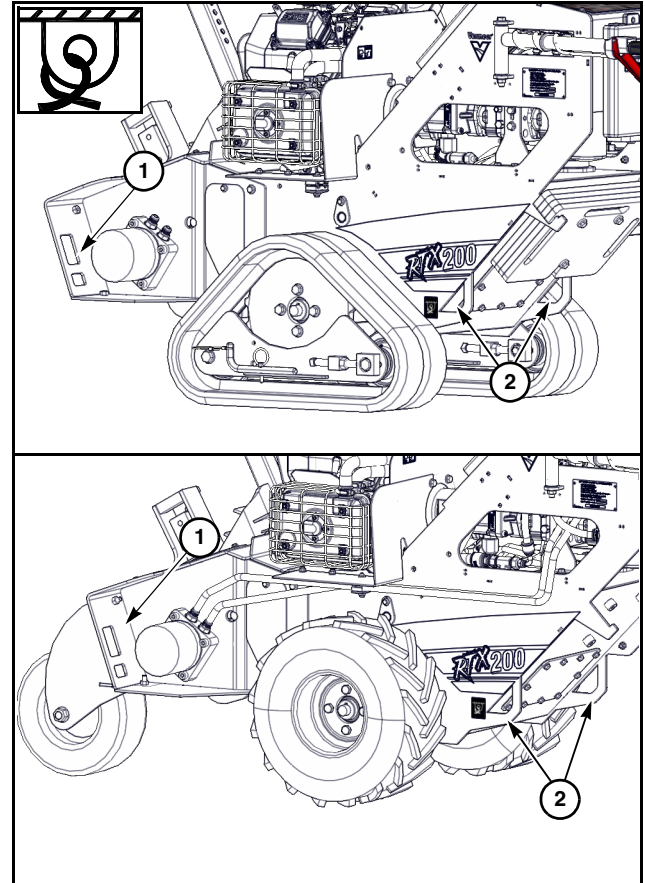

Lifting - single point lift assembly (optional)



WARNING: Raised load can shift or fall. Death or serious injury could be possible if struck or crushed by falling load. Never allow anyone under a raised load unless load is securely supported to prevent it from shifting or falling.

Step 1: Follow *Shutdown procedure*, page 23-1.

Step 2: Attach lifting chains or straps to (1) to optional lift point frame clevis.

NOTICE: Minimum required working load limit per sling leg is 1,000 lb (450 kg). Minimum sling leg length is 6 ft (2 m).

Step 3: Use suitable equipment to lift and lower machine onto the transport vehicle.

Step 4: Fasten machine to transport vehicle using tie-downs.

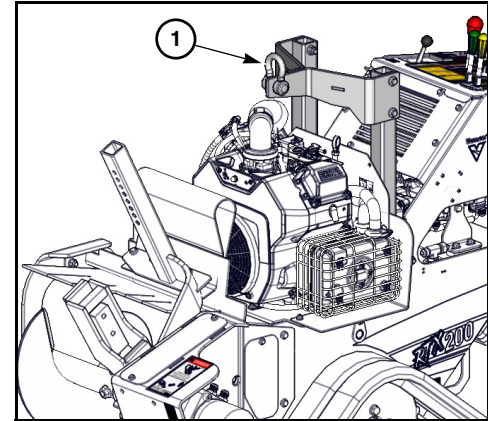

Emergency towing

The machine can be towed slowly a short distance by opening the bypass valves (1), allowing hydraulic fluid to bypass the pump.

Chock wheels/tracks to prevent machine from moving when opening bypass valves with machine on a slope.

Step 1: Follow *Shutdown procedure*, page 23-1.

Step 2: Turn valves (1) on pumps counterclockwise two revolutions. Each valve has a 1/8 in (3 mm) hole so that a metal rod can be used to turn it.

Step 3: Attach appropriately sized tow chain to front (2) or rear tie-down points (3), and tow machine to transport vehicle.

NOTICE: Do not exceed 1–2 mph (2–3 km/h) when towing. Higher speeds will cause heat buildup which will damage hydraulic motor.

Step 4: After towing, tighten tow valves (1); torque to 9–10 ft-lb (12.2–13.6 Nm).

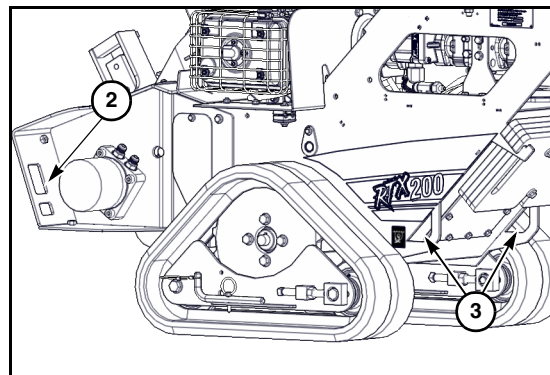
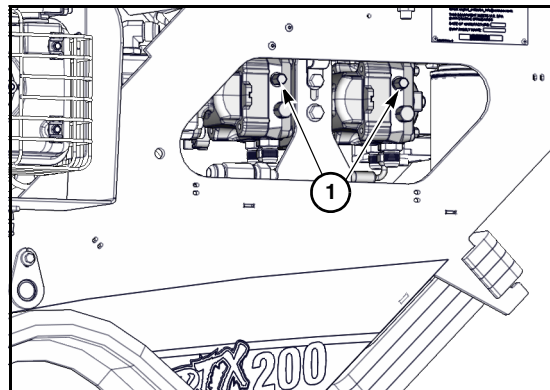

This page intentionally left blank.

Section 40: Preparing machine and work area

Operator qualifications

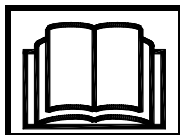

WARNING: Read operator's manual and safety signs before operating machine.

Allow only responsible, properly instructed individuals to operate machine.

Become familiar with the *controls*, operation and use of the machine under the supervision of a trained and experienced operator.

The operator must be familiar with the workplace's safety rules and regulations, and must be mentally and physically capable of operating the machine safely.

Personal protection



WARNING: Wear personal protective equipment. Wear close-fitting clothing and confine long hair. Avoid jewelry, such as rings, wristwatches, necklaces, or bracelets.

Operating the machine will require you to wear protective equipment. You should always wear a hard hat, safety shoes, hearing protectors and eye protection. If working near traffic, wear high visibility clothing.

Hearing protection is recommended when operating the machine. Hearing protection devices provide differing levels of sound reduction. It is important to select a device that is adequate and appropriate for your specific work environment. Actual sound levels may vary widely, depending on your working conditions. To determine the level of hearing protection your work environment requires, enlist the help of your local environmental noise specialist.

Eye protection must consist of wraparound safety glasses or goggles.

Other workers in the immediate area must also wear hard hats, safety shoes, hearing protection and eye protection.

Wear close-fitting clothing and confine long hair.

Avoid wearing jewelry, such as rings, wristwatches, necklaces or bracelets.

Sound and vibration levels

Sound pressure and sound power levels were determined according to test procedures specified in ISO 3744 and ISO 6394.

Equivalent continuous a-weighted sound pressure
at operator's ear 89 dB(A)

Guaranteed sound power level as determined by EU Directive 2000/14/EC 104 dB(A)

Hand/arm vibration exposure has been measured according to test procedures specified in ISO 5349.

Hand/arm vibration, track option 4.52 m/s²

Hand/arm vibration, tire option. 1.46 m/s²

The stated sound levels are representative for a given operating condition. Operating conditions may vary at each jobsite. The actual sound levels for your application and operating conditions may be different.



Operator presence switch - check

The operator presence system uses one red *lever* below the left handlebar to detect the presence of an operator. The operator must pull up this *lever* for the ground drive or attachment drive to be operated.

If the operator releases the *lever* while the ground drive or attachment drive is engaged, the engine will stop. The *ground drive* and *attachment drive controls* must be returned to neutral before restarting the engine.

The operator presence system is intended for your safety and must be maintained in good functional condition. Contact your Vermeer dealer if it does not function properly.

Prepare the area

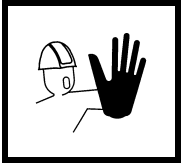

WARNING: Keep all spectators and other workers away from the machine and work area while in operation.

Underground utility contact

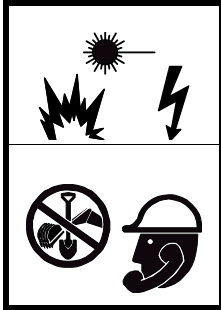

WARNING: Striking an electrical line can cause electrocution. Striking gas line can cause an explosion. Cutting a fiber optic cable could result in eye damage caused by laser light. Death or serious injury possible.

Locate utilities before digging. Call 811, 1-888-258-0808, or access www.call811.com, (U.S. only); or contact local utility companies or national regulating authority.

Before you start any digging project, contact the local One-Call system in your area and any utility company that does not subscribe to the One-Call system. For areas not represented by One-Call Systems International, contact the appropriate utility companies or national regulating authority to locate and mark underground installations. If all utilities are not properly located, you may have an accident or suffer injuries; cause interruption of services; damage the environment; or, experience job delays.

The One-Call representative will notify participating utility companies of your proposed digging activities. Utilities will then mark their underground facilities by using the following international marking codes:

Red	Electric	Green/Brown	Sewer
Yellow	Gas, oil or petroleum	White	Proposed excavation
Orange	Communication, telephone, TV	Pink	Surveying
Blue	Potable water		

OSHA CFR 29 1926.651 requires that the estimated location of underground utilities be determined before beginning excavation or underground drilling operation. When actual excavation or bore approaches an estimated utility location, the exact location of the underground installation must be determined by a safe, acceptable and dependable method. If utility cannot be precisely located, it must be shut off by the utility company.

Look for evidence of underground placement

Visually check for:

- Notices of underground placements
- Manhole covers
- Drop boxes
- Recent trenching activity

Striking a utility

Electricity



DANGER: Striking an electrical line can energize machine, all connected equipment and surrounding ground surface. Death or serious injury will result due to electrocution to anyone contacting equipment. If strike occurs, do the following:

- Stay on machine; keep feet on platform.
- Contact utility company to shut off electrical power.
- Do not allow anyone to approach the machine or any connected equipment.
- Anyone on ground surface should shuffle away keeping feet close together and on the ground.
- Do not resume operation until utility company declares area safe.

Some circuit breakers automatically reset. Do not assume power has been permanently disconnected until you confirm that the utility company has locked out power to that line.

Gas

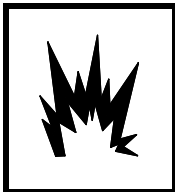

WARNING: Working where flammable gas is present or striking a gas line could result in an explosion. Death or serious injury could result from flying debris, burns or force of explosion. Immediately shut off engine, evacuate area, and contact utility company. Do not return until utility company gives permission to do so.

Fiber optic

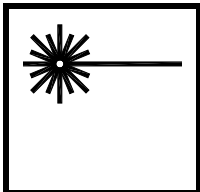

WARNING: Damaged or open fiber optic cable emits laser light which may be invisible and exposes microscopic glass shards. Blindness or serious eye injury could result if exposed to laser light. Damage to skin, lungs and eyes could result due to contact with microscopic glass shards. Do not look into cable. Do not handle cable. Contact appropriate utility company.

Jobsite assessment

Examine work area for any obstructions, conditions or situations which may impair machine operation or create a safety hazard for the operator or other persons. Use information in this manual combined with your own good judgment when identifying these hazards and implementing hazard avoidance measures.

The operator or job foreman should inspect jobsite for:

- Notices of underground placements
- Manhole covers
- Drop boxes
- Recent trenching activity
- Any evidence of possible underground placements
- Banks, overhangs, drop-offs and trenches

When work is planned inside or around structures such as buildings, bridges and low-hanging tree limbs, check for adequate overhead and side clearances.



WARNING: Engine exhaust can asphyxiate or poison resulting in death or serious injury. Operate machine outdoors. If it is necessary to operate engine in an enclosed area, properly vent exhaust gases.

Good ventilation is very important. Sparks from the electrical system and engine exhaust can cause an explosion or fire in a flammable or explosive atmosphere. Do not operate this machine in an area with flammable dust or vapors.

Carbon monoxide fumes from the engine can asphyxiate. Operate only outdoors or provide adequate ventilation if indoor operation is essential.

Prepare the machine

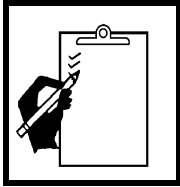

WARNING: Check machine before operating. Machine must be in good operating condition and all safety equipment installed and functioning properly.

- Ensure you understand and comply with all jobsite rules that might apply to your work situation.
- If operating along a road, properly warn and divert motor and pedestrian traffic. Use all necessary signs, cones, flag persons or lighting devices needed for the work situation.

Clean machine

NOTICE: Machine *controls* and electrical/electronic devices are not rated to withstand high pressure water and temperature power washers. Water intrusion will likely cause malfunction or damage to any devices hit directly by the water spray. Keep pressure washer stream away from machine *controls* and electrical/electronic devices. Compressed air can also push moisture through some connector and component seals. Do not point air nozzle directly at seal areas.

Fuel tank - fill

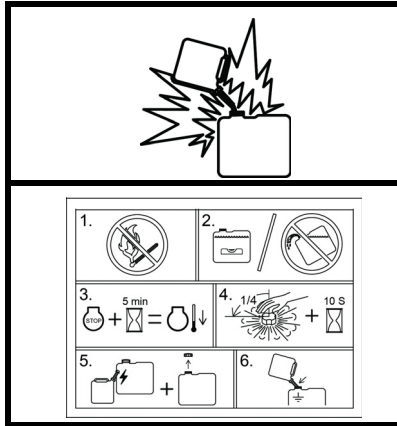

WARNING: Fuel and fumes can explode and burn.

No flame. No smoking. Fill with machine level, do not overfill. Stop engine and let cool for 5 minutes. Turn fuel cap 1/4 turn, wait 10 seconds. Touch spout to tank to discharge static, then remove cap. Keep spout in contact with tank while filling.

Safe fueling practices:

- Do not smoke while fueling. Keep all flames and other ignition sources away.
- Fuel the machine on a level surface. Do not overfill. Stop fueling when the fuel level is below the fuel neck. Do not spill fuel onto the exhaust system or engine while fueling. The spilled fuel could create a large amount of vapors that could potentially ignite.
- Shut off engine and wait five minutes to allow machine to cool before removing the fuel cap and fueling. The exhaust system and hot engine parts can ignite spilled fuel or vapor.
- Before removing the fuel cap, (A) loosen the cap only 1/4 turn and wait 10 seconds for potential pressurized vapor to release slowly. (B) To prevent a static electric spark from igniting fuel or vapors, touch the fuel nozzle or spout to the machine. (C) Remove the fuel cap. (D) Keep the fuel nozzle or spout in contact with the tank neck while fueling to help prevent static electric buildup.

- Use only approved portable containers with a built-in fuel spout or fill with a grounded fuel nozzle.
- Keep the engine and exhaust system free of debris.

Fill fuel tank at the end of each day to prevent condensation. Do not fill tank to the very top, leave room for expansion.

NOTICE: The fuel tank capacity is 2.5 gal (9.5 L). Unleaded gasoline up to 10% ethyl alcohol, 90% is acceptable. Use octane rating of 87 (R+M or higher).

- (1) Fill cap

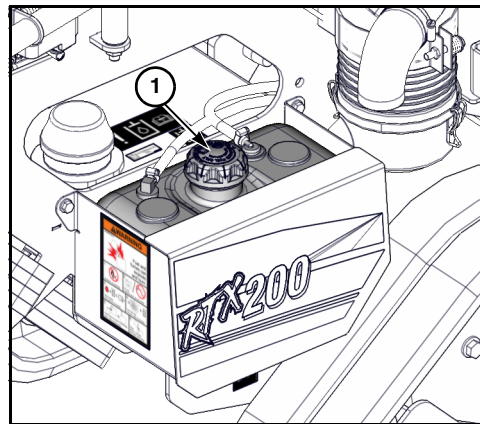

Section 50: Operating the trencher

Operate safely

Operate only from operator's control area.

The machine is equipped with an operator presence system. This system is intended for your safety and must be maintained in good functional condition. The engine must stop if the *operator presence lever* is released while the *propel lever* or *digging chain drive lever* is engaged. Starting the ground drive or digging chain drive without engaging the *operator presence lever* must also stop the engine. Contact your authorized independent Vermeer dealer if system requires repair or adjustment.

Ensure you are familiar with the location and function of each *control* before operating the machine. Refer to "Controls," [page 20-1](#).

Survey the area for obstacles or persons before operating.

Trenching tips

For optimum trenching performance:

- Keep trencher chain adjusted properly.
- For small loose rock or dirt, use cup cutters.
- Ensure cutters are in good condition.
- Rock and frost cutting normally require rotary cutters.
- Some digging conditions, such as mixed aggregate rock that fractures easily and crumbles, may go better with a combination cup cutter and rotary cutter setup.
- Contact your Vermeer dealer for optimal chain setup in your area.
- Do not overload engine while trenching.
- Refer to the maintenance manual for instructions on adjusting chain and replacing/removing cutters.
- If equipped with backfill blade, remove blade before trenching. Refer to “Backfill blade - install/remove,” [page 55-1](#).

Trenching

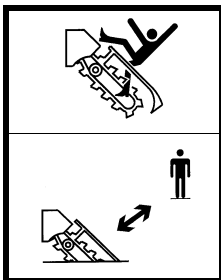

DANGER: Moving digging chain can kill or cut off arm or leg. Trench cave-in may cause you to fall onto moving chain.

Stay away from moving digging chain.

Trench cleaner assembly/restraint bar

The trench cleaner assembly or restraint bar is intended to help protect against accidental personal contact with the digging chain. The trench cleaner assembly or restraint bar must be in place while digging. Refer to the maintenance manual for adjustment instructions.

Trench - start/plunge cut

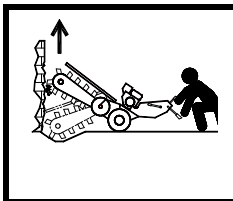

WARNING: The digging chain can suddenly drag the machine forward if the trencher is forced too quickly into the ground or catches on an object. Stay away from houses, fences, trees, and other objects. Digging chain contact with fences, trees, or walls can cause chain to climb upward quickly and turn machine over rearward. Death or injury can result if struck by machine.

Step 1: Line up machine at beginning of trench.

Step 2: Equipped with trench cleaner. Follow [Shutdown procedure](#), page 23-1. If not so equipped, proceed to Step 5.

Step 3: Raise trench cleaner (1), engage latch (2) and secure with linchpin (3).

Step 4: Refer to “Starting procedure,” [page 22-1](#).

Step 5: Pull up on red *operator presence lever* (1).

Step 6: Engage digging chain (5) and move *throttle* to full rpm.

Step 7: Lower trencher boom slowly to the desired digging depth (6).

Lowering boom too quickly will result in excessive boom and machine bounce. A small amount of rearward ground travel during the plunge cut may help in reducing boom and machine bounce.

Do not attempt to force boom down faster than digging chain can remove material. Do not overload engine. If the engine rpm drops or the digging chain slows down, raise boom until speed increases, then continue lowering the boom.

NOTICE: Move machine rearward slightly when making plunge cut to avoid damaging restraint bar or trench cleaner.

Step 8: Use *propel lever* (7) to move machine slowly towards the operator.

Step 9: If using a trench cleaner, follow *Trench cleaner - adjust* instructions. See below.

Step 10: Adjust ground speed for the best productivity when the required trench depth has been reached.

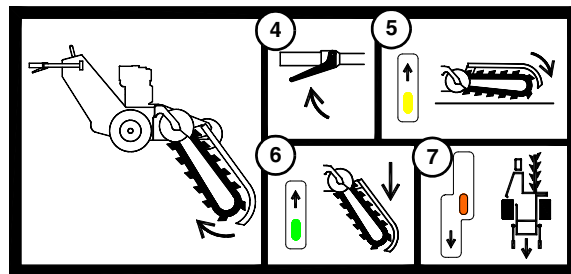
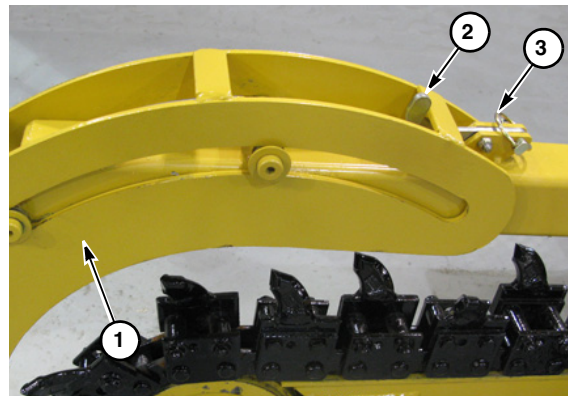

Trench cleaner - adjust



DANGER: Contact with a moving digging chain will result in death or serious injury. Never adjust trench cleaner assembly with the digging chain or engine running.

- Step 1:** After making plunge cut, raise trencher out of ground until boom is level with ground.
- Step 2:** Stop digging chain and shut off engine. Follow [Shutdown procedure](#), page 23-1.
- Step 3:** Remove linchpin (1) to release latch (2). Lower trench cleaner (3). Reinstall linchpin (1) in storage position.

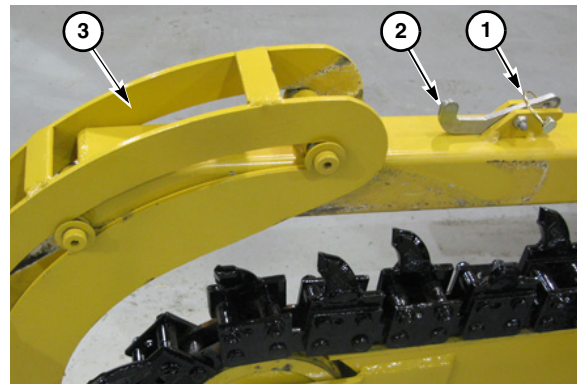

Trench - complete

- Step 1:** Return *propel lever* to neutral to stop machine travel.
- Step 2:** Raise trencher slowly. When the chain is out of the ground, move *digging chain drive lever* to neutral.
- Step 3:** Reduce engine speed to idle.

Freezing temperature precautions

- Check radiator, water systems and pumps for proper temperature protection.
- Clean excess mud and dirt from tracks or other components that could freeze and affect operation.
- Park machine on a hard surface or planks to keep tracks from freezing to the ground.

This page intentionally left blank.

Section 55: Backfill blade (option)

The backfill blade is intended for machines on which backfill blade spacer assembly (1) has been installed. Installation instructions are included with spacer assemblies purchased from Vermeer Parts Center.

The backfill blade is not intended for machines that do not have this assembly installed.

The block supplied with this kit is 3/8 in (1 cm) thicker and 1.75 in (4.4 cm) longer than the factory installed block. This larger block is required for proper backfill blade support.

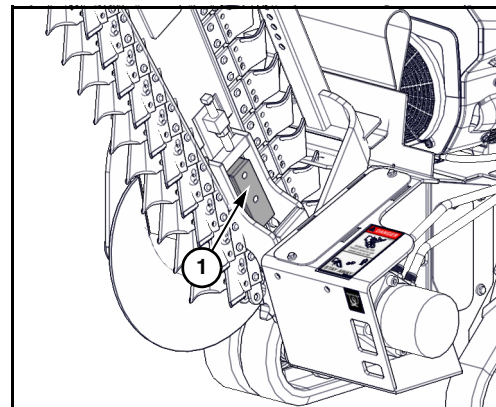

Backfill blade - install/remove

Remove backfill blade before trenching; install it to backfill.

- Step 1: Move *propel lever* to neutral.
- Step 2: Move trencher digging chain to stop.
- Step 3: Raise trencher boom.
- Step 4: Reduce engine speed to idle.
- Step 5: Shut off engine.

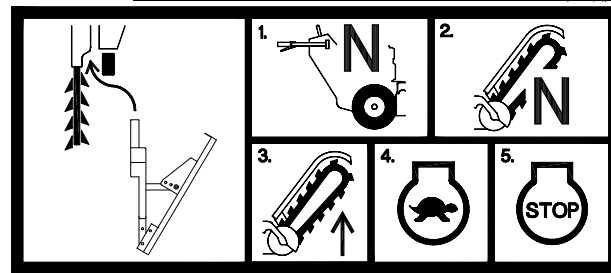

Step 6: Remove adjustment pin from storage position **(1)** and swing blade angle adjustment arm out from blade.

Step 7: Insert pin into one of three holes **(2)** depending on desired working width.
When changing angle after blade is installed on machine, raise blade enough to remove contact with the ground before adjustment.

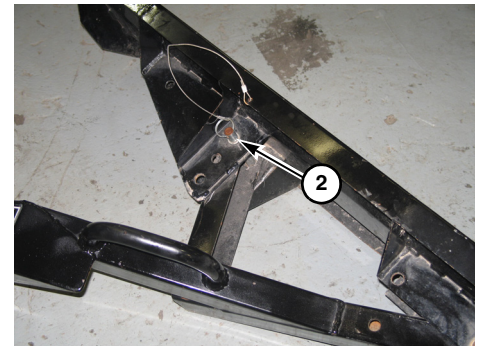
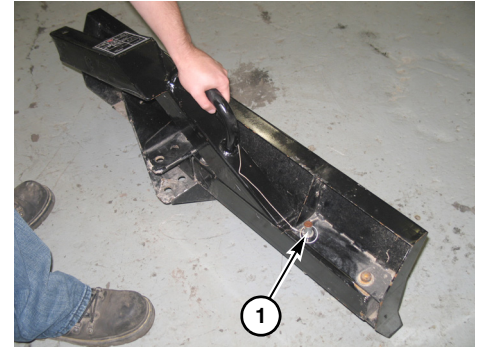
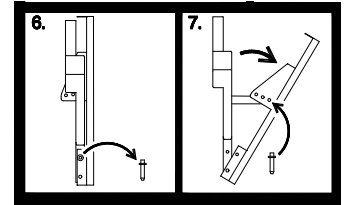

- Step 8: Insert blade arm (3) into pocket (4) on machine.
- Step 9: Pull locking pin (5) to secure blade arm to machine.
- Step 10: Slide blade in pocket until locking pin engages.

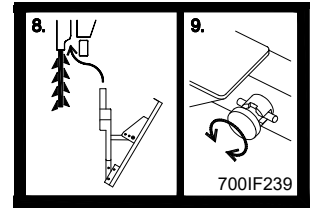

To remove blade:

- Step 1: Follow Steps 1–5 under *Backfill blade - install/remove*. Refer to “Backfill blade - install/remove,” [page 55-1](#).
- Step 2: Pull locking pin (5) to release blade.
- Step 3: Slide blade out of pocket.

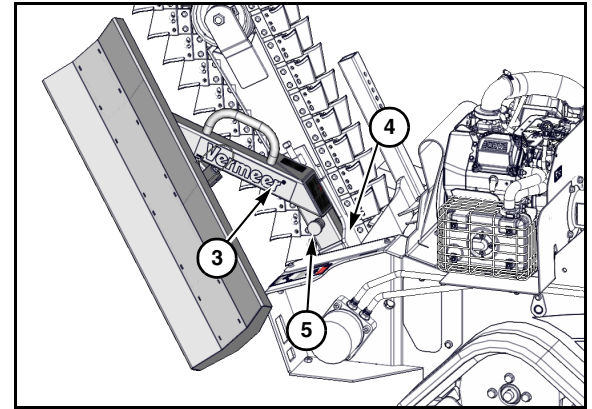

Backfill blade operation



WARNING: Before attempting to operate machine, see “Safety Messages” for important information. Refer to [page 10-1](#).

Familiarize yourself with location and function of the machine *controls* and the *backfill blade controls* before operating. Refer to “Controls,” [page 20-1](#).

Use *trencher lift lever* (1) to raise or lower blade.

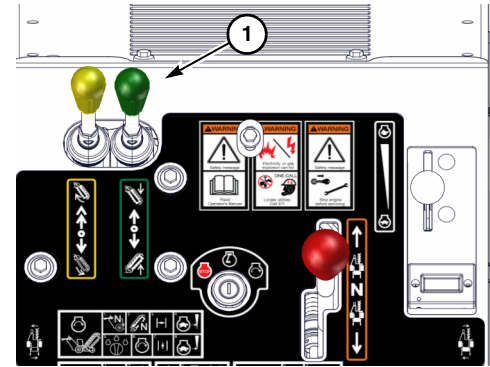

Backfilling

- Step 1:** Use *propel lever* to move machine for backfilling.
- Step 2:** When moving spoil into trench, do not fill blade to full capacity. Make more than one pass at spoil pile. This will result in a better backfilling job.

If engine begins to stall while pushing spoil, reduce amount of spoil being pushed by raising blade or moving more to outside of spoil pile, or by adjusting backfill blade angle. Refer to “Backfill blade - install/remove,” [page 55-1](#).

- Step 3:** Once trench is completely backfilled, drive with one track or one drive tire on trench to compact soil.

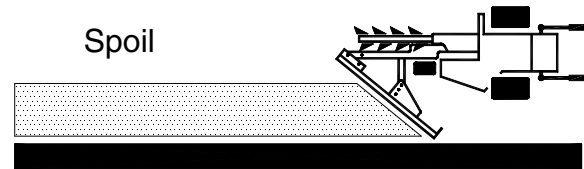

Section 60: Maintenance intervals

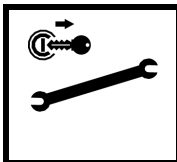

WARNING: Failure to use shutdown procedure can result in unexpected hazard(s). Death or serious injury could result due to entanglement, crushing, cutting, or other hazardous contact. Follow Shutdown Procedure after operating, before performing any service or maintenance, and before transporting. Refer to [Shutdown procedure](#), page 23-1.

Visually inspect machine daily before starting the machine.

Make no modifications to your equipment unless specifically recommended or requested by Vermeer Corporation.

Welding precautions - review

NOTICE: Welding will damage electronic components. Disconnect battery ground to prevent damage.

Review *Welding Precautions* section of the maintenance manual before welding on machine.

Safety signs maintenance

Safety signs located on your machine contain important and useful information that will help you operate your equipment safely.

- Refer to the parts manual for locations.
- Refer to “Controls,” [page 20-1](#).

To assure that all safety signs remain in place and in good condition, follow the instructions given below:

- Keep safety signs clean. Use soap and water - not mineral spirits, abrasive cleaners or other similar cleaners that will damage the sign.
- Replace any damaged or missing safety signs. When attaching signs, the temperature of the mounting surface must be at least 40°F (5°C). The mounting surface must also be clean and dry.
- When replacing a machine component with a safety sign attached, replace the safety sign also.

Replacement safety signs can be purchased from your Vermeer equipment dealer.

Maintenance manual

Maintenance intervals are included for reference only. Before performing any maintenance, refer to the maintenance manual for safety guidelines and correct procedures.

Engine maintenance intervals

Refer to the engine operation manual for additional information and service requirements. Shorten maintenance intervals when operating under dusty, dirty conditions.

Greasing the machine

As a general rule, grease machine after it is shut down for the day. This protects the metal under the seals from corrosion caused by condensation as the temperature drops.

Ensure all fittings and grease applicator nozzle are clean before applying the grease. If any grease fittings are missing, replace them immediately.

Recommended fluids

Refer to the *Specifications* section in the maintenance manual for fluid and lubricant requirements.

Hourmeter - check for maintenance interval/reset (SN 101–310)

The hourmeter (1) is used to determine maintenance intervals for the machine.

Maintenance intervals are based on normal operating conditions. When operating under severe conditions, the maintenance intervals should be shortened.

When a preprogrammed maintenance interval has been reached, the display will flash the service to be performed. For example, at 100 service hours, display will flash “oil change.” Place tip of wand (2) near area (3) along the front edge and wait for several seconds to reset display. Display information can be changed by placing tip of wand (2) near the center of the front edge of the hourmeter (4) and swiping to the side.



Hourmeter - check for maintenance interval (SN 311-)

The hourmeter (1) is used to determine maintenance intervals for the machine. Hourmeter displays engine rpm and machine hours only.

Maintenance intervals are based on normal operating conditions. When operating under severe conditions, the maintenance intervals should be shortened.



Maintenance intervals

Initial = Initial maintenance on new machine. Regular maintenance interval may be different.

- = Regular maintenance interval.

For Vermeer maintenance replacement part numbers, refer to the parts manual or call your Vermeer dealer.

Service	Maintenance interval - service hours							
	5 or twice daily	10 or each use	50	100	200	250	500 or yearly	As required
Outboard bearing - grease	●							
End idler (greaseable option) - grease	●							
Air intake and cooling areas - check/clean		●						

Service	Maintenance interval - service hours							
	5 or twice daily	10 or each use	50	100	200	250	500 or yearly	As required
Engine oil level - check		●						
Air cleaner and element - check		●						
Air cleaner restriction indicator - check		●						
Fuel tank - fill		●						
Hydraulic fluid level - check		●						
Hydraulic oil cooling fan - check/service		●						
Undercarriage - inspect		●						
Track tension - check		●						
Track condition - check		●						
Trencher end idler side play - check		●						
Control levers linkage - oil			●					
Nose wheel bearing - grease			●					
Hydraulic fluid filter - replace			Initial					
Track tension - adjust			Initial					
Spark plug condition - check or replace				●				
Cooling areas - clean				●				
Oil cooler fins - check/clean				●				
Engine oil/filter - change/replace				●				
Trencher components - check				●				
Digging chain - check				●				
Tires and rims - check				●				
Control levers - check				●				
Machine - overall check				●				

Service	Maintenance interval - service hours							
	5 or twice daily	10 or each use	50	100	200	250	500 or yearly	As required
Operator presence system - check				●				
Hydraulic system - check				●				
Neutral start interlocks - check				●				
Safety signs maintenance				●				
In-line fuel filter - replace					●			
Hydraulic fluid filter - replace						●		
Fuel tank and strainer - clean						●		
Bendix starter drive - service							●	
Solenoid shift starter - disassemble/clean							●	
Crankshaft spline - lubricate							●	
Hydraulic fluid - change							●	
Battery electrolyte levels/terminals - check/clean							●	
Battery - replace								●
Air cleaner elements - replace								●
Digging chain - maintain								●
Digging chain drive sprocket - replace								●
Digging chain - adjust								●
Digging chain - remove/install								●
Digging chain wear - check								●
Cutters - replace								●
Trench cleaner/restraint bar - adjust								●
Track tension - adjust								●
Tracks - replace								●

Index

A

After engine starts, 22-2
Avoid battery burns, 22-5
Avoid battery explosion, 22-4

B

Backfill blade - install/remove, 55-1
Backfill blade (option), 55-1
Backfill blade operation, 55-4
Backfilling, 55-4

C

Clean machine, 40-10
Cold-weather starting, 22-3
Controls, 20-1
Crystalline silica, 10-5

D

Dealer prep, i
Dealer/Owner information, iii
Driving the machine, 30-1

E

Electricity, 40-7
Emergency towing, 30-7
Engine controls, 20-1
Engine identification number - record, v

Engine maintenance intervals, 60-2
Engine, 22-3

F

Fiber optic, 40-8
Freezing temperature precautions, 50-5
Fuel tank - fill, 40-11

G

Gas, 40-7
Greasing the machine, 60-3

H

Hourmeter - check for maintenance interval (SN 311–), 60-4
Hourmeter - check for maintenance interval/reset
(SN 101–310), 60-3
Hydraulic fluid, 22-3

I

Identification decals, vi
Intended use, 15-1

J

Jobsite assessment, 40-8
Jump-starting procedure, 22-5
Jump-starting, 22-4

K

L

- Lifting - single point lift assembly (optional), 30-6
- Loading, 30-4
- Look for evidence of underground placement, 40-6

M

- Machine controls, 20-3
- Machine identification numbers - record, iv
- Maintenance intervals, 60-1, 60-4
- Maintenance manual, 60-2

N

O

- Operate safely, 50-1
- Operating the trencher, 50-1
- Operator presence switch - check, 40-4
- Operator qualifications, 40-1

P

- Personal protection, 40-2
- Prepare the area, 40-4
- Prepare the machine, 40-10
- Preparing machine and work area, 40-1

Q

R

- Receiving and delivery report, i
- Recommended fluids, 60-3

S

- Safe operation on slopes, 30-3
- Safety messages, 10-1
- Safety signs maintenance, 60-2
- Safety symbol explanation, 10-1
- Shutdown procedure, 23-1
- Sound and vibration levels, 40-3
- Starting procedure, 22-1
- Starting the engine, 22-1
- Steering the machine, 30-2
- Striking a utility, 40-7

T

- Telematics equipment notice and consent, 1-11
- Trailing the machine, 30-4
- Transporting the machine, 30-1
- Trench - complete, 50-5
- Trench - start/plunge cut, 50-3
- Trench cleaner - adjust, 50-5
- Trench cleaner assembly/restraint bar, 50-3
- Trenching tips, 50-2
- Trenching, 50-3

U

- Underground utility contact, 40-5
- Unloading, 30-5

V

- Vermeer GPS tracking equipment (telematics), 16-1
- Vermeer productivity tools, 16-1

W

Welding precautions - review, 60-1

This page intentionally left blank.

Revision history

Revision	Date	Pages/ Sections	Description
o1_00	03/16	All	First edition production manual released.
o1_01	11/16	Front Section	Added Evap Emissions Warranty
o1_02	07/19	Pages vi, 10-3, 20-1, 60-3	Keyswitch location change. Updated hourmeter.
o1_03	02/20	Introduction, Section 16, Page 60-1	Updated overview picture, Added telematics and reference to Welding precautions
o1_04	10/22	Introduction, 20-2	Updated warranty and emissions control warranty. Updated picture of choke location. New style updates.

⚠ WARNING

The engine exhaust from this product contains chemicals known to the State of California to cause cancer, birth defects, or other reproductive harm.

**CALIFORNIA
Proposition 65 Warning**

Battery posts, terminals, and related accessories contain lead and lead compounds, chemicals known to the State of California to cause cancer and reproductive harm. Wash hands after handling.

© 2022 Vermeer Corporation. All Rights Reserved.
1210 Vermeer Road East, P.O. Box 200
Pella, Iowa 50219-0200 USA